

Information and Requirements for Electric Service

Rev 4.04

Manual Owner: Karen Campanella

June 30, 2022

This Page Intentionally Blank

Record of Revisions

Revision Number	Revision Date	Sections Revised	Reason for Revision
REV 01	June 1, 2005	All	Revised entire <i>Information and Requirements for Electric Service Manual</i> .
REV 02	January 6, 2006	Chapters 1, 2, 4, 6 and Appendix	Additional material in Chapters 1, 2, 4, 6 and Appendix pages A-19, 51, 89 and a new table on A-90.
REV 02.01	November 30, 2006	Appendix	Change graphic in Exhibit 19B.
REV 02.02	April 23, 2008	Chapter 2, Title Page	Typo in Table 2-2, change Manual Owner.
REV 3.00	May 31, 2014	All	Complete review of entire manual.
REV 3.01	January 15, 2017	Chapters 1, 5, 6, 9, 10, 11 and Index	Chapter 1 – Updated abbreviations in Section 1 and 3.1. Chapter 5 – Updated Section 3, Bulletin 16-066. Chapter 6 – Updated Figure 6.1 Chapter 9 – Updated abbreviations in Section 2. Chapter 10 – Updated Table 10-7, Bulletin 16-034. Updated Figures 10.9, 10.37, 10.38, 10.42, 10.43 and 10.44, Bulletin 16-066. Chapter 11 – Added New Chapter 11 – General Specification for Service to High-Rise Buildings, Bulletin 16-079. Index – Updated Index.
REV 4.00	May 18, 2018	All	Cover-to-cover review of entire manual completed in 2018 Implemented new template for entire manual Created a Forms chapter before the Index. Chapter 1: <ul style="list-style-type: none"> • Updated Section 1 – Purpose. • Updated Section 2 – Clarifications. • Deleted Section 3.6 – Designated Growth Area. • Changed title of Section 3.16 from Metalclad Switchgear to Metal Enclosed Switchgear. • Deleted Section 3.18 – Non-Growth Area. • Updated Section 4 – Ownership, Maintenance and Removal of Apparatus Provided by or for PSE&G. • Updated Section 8, paragraph 1. • Updated Section 13 and changed title from Expediting Electric Service to Pre-Requisites for Electric Service. • Deleted Section 16 – Smart Growth Related Customer Charges and Contributions. Chapter 2: <ul style="list-style-type: none"> • Updated Table 2-1. • Updated Section 2 – Service from the Primary System. Chapter 3: <ul style="list-style-type: none"> • Deleted Table 3-3 from Section 2.2. • Updated Section 3, paragraph 3.

Revision Number	Revision Date	Sections Revised	Reason for Revision
REV 4.00 Cont'd	May 18, 2018	All	<ul style="list-style-type: none"> • Updated Section 4, paragraphs 2, 4 and 6. • Updated Section 5, paragraph 3. • Updated Section 6, paragraphs 1 and 4. • Updated Section 7. • Updated Section 8, paragraph 1. • Updated Section 9. • Updated Section 10, introductory paragraph and paragraph 2. • Updated Section 11, introductory paragraph and paragraphs 1, 2 and 7. Deleted paragraphs 8 and 9. <p>Chapter 4:</p> <ul style="list-style-type: none"> • Updated Section 1, paragraphs 1 and 4. • Added paragraph 7 to Section 2. • Updated Section 3, paragraph 2. • Updated Section 4, paragraph 4. • Updated Section 5, paragraph 1. • Updated Section 6, paragraph 2, 3, and 5. Deleted paragraph 6 and renumbered subsequent paragraphs. • Updated Section 7, paragraph 4. • Updated Section 8, paragraph 2, 3 and 5 <p>Chapter 5:</p> <ul style="list-style-type: none"> • Updated Section 1, paragraph 7. Added new paragraph 10 and renumbered subsequent paragraphs. • Updated Section 2, paragraphs 2, 5, 7, 8, 9 and 10. • Updated Section 3, paragraphs 8, 10 and 11. <p>Chapter 6:</p> <ul style="list-style-type: none"> • Added new paragraph 5 to Section 2 and renumbered subsequent paragraphs. • Updated Section 7, paragraph 5 and added paragraph 10. • Added “Fire Pumps” the Section 8 heading and paragraphs 1 and 3. • Updated Section 12, paragraph 4. Added new paragraph 6. • Updated Section 15. Moved paragraph 3 to paragraph 1 and added paragraph 13. • Added Section 16. <p>Chapter 7:</p> <ul style="list-style-type: none"> • Converted all forms to a standard format. Created fillable forms. • Updated Sections 1.1 and 1.2. <p>Chapter 8:</p> <ul style="list-style-type: none"> • Updated Southern Construction Inquiry phone number ins Table 8-1. • Removed Division Office phone numbers in Table 8-2. <p>Chapter 9:</p> <ul style="list-style-type: none"> • Spelled out meaning of PJM in definition of PJM. • Updated any occurrence of NJAC to N.J.A.C. • Added Figures 9.1 and 9.2. • Updated Section 4.5 and added Section 4.7.

Revision Number	Revision Date	Sections Revised	Reason for Revision
REV 4.00 Cont'd	May 18, 2018	All	<p>Chapter 10:</p> <ul style="list-style-type: none"> • Updated reference from Chapter 1 Section 16 to Chapter 1 Section 17. • Updated Section 1.1, paragraph 2. Added paragraph 3. • Added note for F, updated Hand added I in the notes for Figure 10.1 and updated note 2. • Inserted Section 2 – Grouped Meter Mounting Equipment Specifications and Figure 10.2. Renumbered subsequent sections and figures. • Updated notes 3, 6 and 11 in the notes for Figures 10.4, 10.5 and 10.6. • Updated notes 9, 12 and 13 in the notes for Figures 10.8, and 10.9. • Updated notes 3, and 7 in the notes for Figures 10.11, and 10.12. • Updated Section 9.1, paragraphs 4, 5, 6, 13, 15 and 16, and removed 3-12 in. conduit diameter from Table 10-2. • Updated note 4 under Customer shall in the notes for Figures 10.16, 10.17 and 10.18. • Added notes 4 and 5 under Customer shall in the notes for Figure 10.19. • Updated notes 3, and 6 in the notes for Figure 10.26. • Updated title of Figure 10.27 to >801 A and updated notes 6, 7 and 11. • Updated notes 6, and 10 and added note 12 in the notes for Figure 10.28. • Updated note 1 under PSE&G will and updated notes 6 and 10, and added note 12 under Customer shall in the notes for Figure 10.29. • Added /Switchgear to the end of Section 18 heading. • Updated note 9 in the notes for Figure 10.30. • Added /Switchgear to the end of Section 19 heading and added > before 801 A. Updated note 4 for Figure 10.31. • Updated note 10 in the notes for Figure 10.31. • Updated notes 1, 2 and 3 in Section 21.1.1. • Updated Section 21.1.3. • Updated Section 25.2 paragraphs 1 and 4. • Updated first paragraph under Section 25.4 • Updated notes 4, 7, 9, and 10 and added note 15 in notes for Figure 10.38. • Updated Section 27 to 300 kVA and below. • Updated Section 27.1 and 27.3. • Deleted Figure – Fiberglass Pad Three-Phase Padmounted Transformers (500 kVA and below) – Type II (Highline Previous Design Type II Pad). • Updated Figure 10.39 title to 300 kVA and below. • Updated Section 28.2, paragraph 1. • Deleted “– Overhead Zones” from the end of Section 29 heading. • Added bullet to Section 29.1 paragraph 3. • Added “For Overhead Type Transformers” to Section 29.2 heading and updated paragraphs 2, 3, 4, 6, 8 and 9. • Deleted note 5 in notes for Figures 10.43 and 10.44. • Changed Figure “Vault Requirements – Customer-Installed Transformer Vault – Network Type Vaults Only” to Section 29.3. • Deleted figure “Vault Requirements – Customer-Installed Transformer Vault – Non-Network Type Vaults Only.” • Added Figures 10.46 and 10.47. • Updated Section 30.1 paragraph 2.

Revision Number	Revision Date	Sections Revised	Reason for Revision
REV 4.00 Cont'd	May 18, 2018	All	<ul style="list-style-type: none"> • Updated Section 30.3 paragraph 2. • Updated Figures 10.1, 10.8, 10.11, 10.12, 10.13, 10.16, 10.17, 10.18, 10.19, 10.21, 10.23, 10.25, 10.28, 10.29, 10.30, 10.34, 10.39, 10.40, 10.41, 10.43, 10.44, 10.46 and 10.48. • Deleted Figure “Elevated Pad Specs – Installations in Flood Areas.” • Updated Table 10-7. Chapter 11: <ul style="list-style-type: none"> • Updated Section 1. • Updated Section 3.2, paragraph 4. • Updated Section 4.1 • Updated Section 8, paragraph 3. • Updated Figure 11.1.
REV 4.01	November 30, 2018	Title page, TOC, Introduction, Chapters 3, 4, 6, 8, 10 and 11.	Introduction – Updated sample reference and Section 8. Chapter 3 – Updated Section 3 number 4 and Section 4 number 7. Removed “open” from “120/240 three-phase four-wire open delta services.” from the last sentence of each paragraph. Chapter 4 – Updated Section 6 number 5, 1st bullet to “265/460 V” from “265/240V.” Chapter 6 – Section 16.2 – Added PSE&G – Central Sub Division Headquarters 72 W. Jersey Street, Elizabeth, NJ 07202, Patricia D’Alia (908) 558-7520 Fax (908) 353-7642. Chapter 8 – Table 8-1– added Electric Division of “M” to municipality of Hackensack and updated the Electric Division in the municipalities of Perth Amboy, Woodbridge, North Plainfield, Watchung and Plainfield from “CS” to “C.” Chapter 10 – Updated Figure 10.1 Notes. Updated Section 21.1.3 – removed “open” from “120/240 three-phase, four-wire open delta services.” Added “(primary)” and “(secondary)” to Figure 10.35 Note – General number 1. Chapter 11 – Section 2 – updated definition of “Internal Distribution System.” Section 4.1.1 changed “216Y/125” to “208Y/120” for customer requirements. Section 9 changed “216Y/125” to “208Y/120.” Updated Figure 1.1.

Revision Number	Revision Date	Sections Revised	Reason for Revision
REV 4.02	October 17, 2019	Title page, TOC, LOF, LOT, List of Forms, Introduction, Chapters 3, 4, 5, 6, 8, and Index	<p>Chapter 1 – Updated reference from N.J.A.C. 14:5-4.1 to N.J.A.C 14:3-8.4 in Sections 3.3 and 6 paragraph 5.</p> <p>Chapter 3 – Updated reference from N.J.A.C. 14:5-4.1 to N.J.A.C 14:3-8.4 in Section 5 paragraph 1. Updated Section 11, paragraph 2. Added “The number of secondary sets cannot exceed 10 and a full neutral must be provided.”</p> <p>Chapter 4 – Updated terminology in Sections 6 and 7 from disconnecting to interrupting. Updated Section 6, paragraph 6. Changed “No other devices or uses are permitted on the supply side of the meter. No customer owned volt meters, ammeters, or any other monitoring devices, shall be installed prior to PSE&G metering.” to “No other customer owned voltage transformers, shall be installed prior to PSE&G metering without written approval from PSE&G Inspection Supervisor.”</p> <p>Chapter 5 – Updated references to Chapter 10 figures.</p> <p>Chapter 6 – Updated Section 16.1. Added the following bullets:</p> <ul style="list-style-type: none"> • All attachments must be within the pole manufacturer’s guidelines for the Effective Projected Area (EPA) calculations. • Attachments from pole to pole are prohibited. <p>Chapter 8 – Changed the Electric Division for the City of Hackensack from “M” to “P” in Table 8-1.</p> <p>Chapter 10 – Update title of Figure 10.18. Added Figure 10.19: Three-Phase Four-Wire Services, Voltages Greater than 250 (Cold Sequence). Renumbered subsequent figures. Updated Figures 10.20, and 10.21. Deleted Figure 10.22. Renumbered subsequent figures. Updated Figures 10.22 and 10.23. Figure 10.24 divided in to two figures becoming Figures 10.24 and 10.25. Renumbered subsequent figures. Updated Figure 10.42. Added new Figure 10.52: Metered Installation for third Party Equipment on Secondary Distribution Pole. Renumbered subsequent figures. Updated Table 10-7.</p>
REV 4.03	November 24, 2020	Title page, TOC, Introduction, Chapters 3, 4, 10 and 11	<p>Changed customer installed to customer-installed in Chapters 3, 4, 10 and 11.</p> <p>Chapter 10 – Revised Section 10.1 paragraph 2.</p>
REV 4.04	June 30, 2022	Title page, Introduction and Chapter 11	<p>Changed Manual Owner from James Duswalt, Manager – New Business and Work Management to Karen Campanella, Manager Business Processes.</p> <p>Chapter 11 – Updated Section 4.1</p>

This Page Intentionally Blank

Table of Contents

List of Figures	xv
List of Tables	xvii
List of Forms	xix
Introduction	xxi
1 Overview	xxi
2 Safety	xxi
3 New Format	xxi
4 Latest Version	xxii
5 Updates	xxii
6 How to Use this Manual	xxii
7 Symbols	xxiii
8 What's New	xxiii
9 Ownership and Confidentiality	xxiv
Chapter 1 – General – Contents	1-TOC 1
Chapter 1 – General	1-1
1 Purpose	1-1
2 Clarifications	1-1
3 Definitions of Terms	1-2
4 Ownership, Maintenance and Removal of Apparatus Provided by or for PSE&G	1-6
5 PSE&G Responsibility for Electric Installations	1-7
6 Application for Service	1-7
7 Application for Wiring Inspection	1-8
8 Inspection and Acceptance of Customer's Installations	1-8
9 Permits	1-9
10 Prevention of Damage to Underground Electric and Gas Facilities	1-9
11 Sealing of Meters and Devices	1-10
12 Theft of Service and Tampering	1-10
13 Pre-Requisites for Electric Service	1-10
14 Access to Customer's Premises	1-11
15 Customer Requested Shutdown	1-11
16 Environmental Issues	1-12

17 Customer Charges and Contributions	1-12
Chapter 2 – Characteristics of Electric Service – Contents	2-TOC 1
Chapter 2 – Characteristics of Electric Service	2-1
1 General	2-1
2 Service from the Primary System	2-3
3 Service from the Subtransmission System	2-3
4 Service from the Transmission System	2-4
5 Feasibility Study Charges	2-4
Chapter 3 – Service Runs – Contents	3-TOC 1
Chapter 3 – Service Runs	3-1
1 General	3-1
2 Temporary Services	3-2
3 Overhead Secondary Service Run in an Overhead Zone	3-4
4 Underground Secondary Service Run in an Overhead Zone	3-5
5 Residential Buried Underground Distribution (BUD) Systems	3-6
6 Secondary Service Runs in an Underground Zone	3-6
7 Overhead Primary Service Runs in an Overhead Zone	3-7
8 Underground Primary Service Runs in an Overhead Zone	3-7
9 Primary Service Runs in an Underground Zone	3-8
10 Padmounted Transformer Installations – Secondary Metered	3-8
11 Transformer Vault Installation – Secondary Metered	3-9
Chapter 4 – Service Entrance Installations – Contents	4-TOC 1
Chapter 4 – Service Entrance Installations	4-1
1 General	4-1
2 Grounding	4-2
3 Secondary Service Entrance Installations for Overhead Connection from Overhead Mains	4-2
4 Secondary Service Entrance Installations for Underground Connection from Overhead Mains	4-3
5 Secondary Service Entrance Installations for Connections from Underground Mains	4-4
6 Secondary Distribution Service Equipment	4-5
7 Specifications for Primary Service	4-6
8 Requirements for Switchgear Review	4-6
9 Non-Utility Generators (NUGs)	4-7

Chapter 5 – Meters and Auxiliary Equipment – Contents	5-TOC 1
Chapter 5 – Meters and Auxiliary Equipment	5-1
1 General	5-1
2 Metering Transformers and Associated Equipment	5-3
3 Multiple Meter Installations for Residential Unit Buildings and Office Buildings	5-4
4 Check Metering	5-5
Chapter 6 – Customer’s Installations – Contents	6-TOC 1
Chapter 6 – Customer’s Installations	6-1
1 General	6-1
2 Motors – Starting Current	6-1
3 Motor Installations	6-3
4 Welders, Furnaces and Intermittent or Fluctuating Loads	6-4
5 Ranges, Ovens and Heaters	6-5
6 Gaseous Tube Lighting or Sign Equipment	6-5
7 Non-Utility Generators (NUGs) and/or Parallel Operations with PSE&G	6-5
8 Fire Alarms, Fire Pumps and Exit Lights	6-6
9 Voltage Sensitive Equipment	6-7
10 Load Management Services	6-8
11 Police and Fire Systems	6-8
12 Traffic Signal Systems and Roadway Lighting	6-8
13 Cellular Antenna Sites	6-8
14 Community Antenna Television (CATV) Power Supplies	6-9
15 Closed Circuit Camera Installation Requirements	6-9
16 Attachment of Holiday Decorations, Banners and Signs to Poles	6-13
Chapter 7 – Miscellaneous Forms and Applications – Contents	7-TOC 1
Chapter 7 – Miscellaneous Forms and Applications	7-1
1 PSE&G’s Service Removal (Demolition) Process	7-11
Chapter 8 – Electric Territory Served – Contents	8-TOC 1
Chapter 8 – Electric Territory Served	8-1
Chapter 9 – Class 1 Renewable Energy Interconnections – Contents	9-TOC 1
Chapter 9 – Class 1 Renewable Energy Interconnections	9-1

1	General	9-1
2	Definitions/Acronyms	9-1
3	Process	9-3
4	Applicants/Facility Requirements	9-6
5	Renewable Generation in Network Areas (Level 3)	9-10
6	Additional Resources	9-16
Chapter 10 – Additional Information and Illustrations – Contents		10-TOC 1
Chapter 10 – Additional Information and Illustrations		10-1
1	Service Entrance Clearances	10-1
2	Grouped Meter Mounting Equipment Specifications	10-4
3	Outdoor Socket Overhead Secondary Service	10-5
4	Unacceptable Service Location	10-8
5	Indoor Enclosure Overhead Secondary Service	10-9
6	Service Entrance Mast – Galvanized Rigid Steel Conduit	10-11
7	Service Entrance Installations	10-12
8	Secondary Distribution Service Entrance – Underground Connections from Overhead Mains	10-13
9	Typical Conduit and Trench Details – BUD Installations Only	10-15
10	Specifications for Customer-Installed Underground Service Conduit – Overhead Zone	10-17
11	Single-Phase, Two-Wire 120 V for Two-Wire Socket Meter	10-21
12	Single-Phase Three-Wire 120/208 or 120/240 V Three-Wire Socket Meter	10-23
13	Three-Phase, Three-Wire, 240 V Service – Ungrounded System	10-25
14	Three-Phase, Four-Wire Services	10-26
15	Grounding and Bonding	10-30
16	Approved Type Current Transformer Cabinet	10-36
17	Secondary Service Equipment with Bar Type Current Transformers (CTs)	10-40
18	Minimum Clearances and Bus Arrangement for Bar Type Current Transformers 200 to 800 A Secondary/Switchgear	10-44
19	Mounting Dimensions for Current Transformers in Cubicle – Window Type >801 A to 4000 A Secondary/Switchgear	10-46
20	Current Transformer Mounting Bracket Specifications and Dimensions	10-48
21	Service Runs	10-49
22	Fiberglass Pad – Present Design Single-Phase	10-51
23	Secondary Conduit Connections for Single-Phase Open Delta Transformer	10-52

24	Single-Phase Padmounted Transformer – Open Delta Connections	10-53
25	Single-Phase Padmounted Transformer Pads	10-54
26	Three-Phase Padmounted Transformers	10-57
27	Fiberglass Pad Three-Phase Padmounted Transformers (300 kVA and Below) – Type II.	10-60
28	Pad Construction Detail.	10-62
29	Guide for Construction of Customer-Installed Transformer Vaults – Secondary Metered	10-66
30	Minimum Requirements for a Temporary Service Mast	10-73
31	Underground Temporary Service Mast	10-76
32	Community Antenna Television (CATV)	10-78
33	Limiter Lug Assembly – 350 MCM and 500 MCM 600 V Rubber Insulated Service Cable	10-82
34	Net Metering	10-84
35	New Jersey One-Call System.	10-86
36	Padmounted Transformer Installations – Secondary Metered	10-88
Chapter 11 – General Specification for Service to High-Rise Buildings – Contents		11-TOC 1
Chapter 11 – General Specification for Service to High-Rise Buildings.		11-1
1	General	11-1
2	Definitions	11-1
3	General Specification.	11-2
4	Types of Service	11-2
5	General Specification Certification	11-4
6	Site Specific Specification	11-4
7	Service Sketch.	11-4
8	Customer Requirements	11-4
9	Company Requirements	11-5
10	Site Specific Certification.	11-5
Forms		Form-1
Index		Index-1

This Page Intentionally Blank

List of Figures

Figure 6.1: Closed Circuit Camera Attachments to Street Light Poles (Wood)	6-10
Figure 6.2: Metal Straps to Mount CCTV Camera Bracket Round Metal and Wooden Street Light Poles	6-12
Figure 6.3: Camera Attachment to Wood Pole	6-12
Figure 6.4: Camera Attachment to Metal Pole	6-13
Figure 7.1: Sample of Temporary Electric Service(s) Application (ED-DC-IRE-Form001)	7-2
Figure 7.2: Sample of Permanent Electric Service(s) Load Information (ED-DC-IRE-Form002)	7-3
Figure 7.3: Sample of Commercial/Industrial Project Contact Information Sheet (ED-DC-IRE-Form003)	7-4
Figure 7.4: Sample of Residential Project Contact Information Sheet (ED-DC-IRE-Form004)	7-5
Figure 7.5: Sample of Motor Data Sheet – 100 Horsepower and Above (ED-DC-IRE-Form005)	7-6
Figure 7.6: Sample of Resistance Welder Data Sheet (ED-DC-IRE-Form006)	7-7
Figure 7.7: Sample of Power Quality Data Sheet (Page 1 of 2) (ED-DC-IRE-Form007)	7-8
Figure 7.8: Sample of Power Quality Data Sheet (Page 2 of 2) (ED-DC-IRE-Form007)	7-9
Figure 7.9: Sample of Service Removal Request Application (Demolition) (ED-DC-IRE-Form008)	7-10
Figure 9.1: Current Transformer Rated Solar Loan Configuration	9-9
Figure 9.2: Self-Contained Residential Solar Loan Wiring Configuration	9-10
Figure 9.3: Area Network	9-12
Figure 9.4: Minimum Import Relay	9-15
Figure 10.1: Minimum Clearances for Overhead Services	10-2
Figure 10.2: Exhibit 1 – Self-Contained, Single-Phase, Three-Wire 120/240V, 120/208V Network	10-4
Figure 10.3: First Floor Installation	10-5
Figure 10.4: Panel Located in Basement	10-6
Figure 10.5: Grounding to Water System	10-6
Figure 10.6: Diagram of Typical Installation – Unacceptable Service Location	10-8
Figure 10.7: Non-Standard Installation – Special Approval Required – First Floor Installation	10-9
Figure 10.8: Non-Standard Installation – Special Approval Required – Basement Installation	10-10
Figure 10.9: Service Entrance Mast – Galvanized Rigid Steel Conduit	10-11
Figure 10.10: Service in Conduit	10-13
Figure 10.11: Direct Buried Service	10-14
Figure 10.12: Service Connection	10-15
Figure 10.13: Street Crossing	10-16
Figure 10.14: Standard Trenches	10-16
Figure 10.15: Single-Phase, Two- Wire 120 V for Two-Wire Socket Meter	10-21
Figure 10.16: Single-Phase, Three-Wire, 120/208 or 120/240 V Three-Wire Socket Meter	10-23
Figure 10.17: Three-Phase, Three-Wire, 240 V Service – Ungrounded System	10-25
Figure 10.18: Three-Phase, Four-Wire Services – Voltage Less than 250 V	10-27
Figure 10.19: Three-Phase Four-Wire Services, Voltages Greater than 250 V (Cold Sequence)	10-29
Figure 10.20: 120/208 or 120/240 V Service	10-30
Figure 10.21: Trough with Multiple Enclosures, 120/208 or 120/240 V Service – Main Interrupting Device Before Meters	10-31

Figure 10.22: Meter Location Remote from Service Entrance Load Interrupting Device but in Same Building 10-32

Figure 10.23: Combination Power and Light (4 W Delta Service) 10-33

Figure 10.24: Grounding and Bonding CT Enclosure – Hot Sequence, Bar Type CT 10-34

Figure 10.25: Grounding and Bonding CT Enclosure – Cold Sequence Bar Type CT 10-35

Figure 10.26: Maximum Capacity Parallel 500 kcmil Conductors 10-36

Figure 10.27: Window Type >801 A Secondary 10-38

Figure 10.28: Maximum Capacity Parallel 500 kcmil Conductors – Three-Wire Services Single-Phase or Three-Phase 10-40

Figure 10.29: Maximum Capacity Parallel 500 kcmil Conductors – Three-Phase Four- Wire Service 10-42

Figure 10.30: Minimum Clearances and Bus Arrangement for Bar Type Current Transformers 200 to 800 A Secondary 10-44

Figure 10.31: Mounting Dimensions for Current Transformers in Cubicle – Window Type >801 A to 4000 A Secondary 10-46

Figure 10.32: Current Transformer Mounting Bracket Specifications and Dimensions 10-48

Figure 10.33: Secondary Connections to Terminals of PSE&G Equipment 10-50

Figure 10.34: Fiberglass Pad – Present Design Single-Phase 10-51

Figure 10.35: Secondary Conduit Connections for Single-Phase Open Delta Transformer 10-52

Figure 10.36: Single-Phase Padmounted Transformer – Open Delta Connections 10-53

Figure 10.37: Single-Phase Padmounted Transformer Pads 10-55

Figure 10.38: Three-Phase Padmounted Transformers 10-57

Figure 10.39: Fiberglass Pad Three-Phase Padmounted Transformers (300 kVA and below) – Type II (Highline Current Design Type II Pad) 10-61

Figure 10.40: Three-Phase Padmounted Transformer – Type II-A (Concrete) 10-62

Figure 10.41: Three-Phase Padmounted Transformer – Type III-A (Concrete) 10-64

Figure 10.42: Three-Phase Padmounted Transformer – Type V-A (Concrete) 10-65

Figure 10.43: Transformer Vault Minimum Construction Dimensions Single – Up to Three 500 kVA Transformers 10-68

Figure 10.44: Transformer Vault Minimum Construction Dimensions Single – Up to Three 500 kVA Transformers Double – Up to Six 500 kVA Transformers 10-69

Figure 10.45: Network Vault Specifications – 120-208 V 10-71

Figure 10.46: Network Vault Specifications – 277-480 V 10-72

Figure 10.47: Minimum Requirements for a Temporary Service Mast 10-73

Figure 10.48: Underground Temporary Service Mast 10-76

Figure 10.49: Typical Service Installation CATV 120 V Power Supply Pedestal 10-78

Figure 10.50: Community Antenna Television (CATV) Power Supply on Joint Pole 10-80

Figure 10.51: Limiter Lug Assembly – 350 MCM and 500 MCM 600 V Rubber Insulated Service Cable 10-82

Figure 10.52: Net Metering 10-84

Figure 10.53: Metered Installation for third Party Equipment on Secondary Distribution Pole 10-85

Figure 10.54: Call Before You Dig (Page 1) 10-86

Figure 10.55: Call Before You Dig (Page 2) 10-87

Figure 10.56: Padmounted Transformer Installations – Secondary Metered 10-89

Figure 11.1: Example of One Line Diagram 11-6

List of Tables

Table 2-1: Recommended Secondary Service kVA Demands	2-3
Table 2-2: Recommended Primary, Subtransmission and Transmission Service kVA Demands	2-4
Table 3-1: Service Drop and Meter	3-3
Table 3-2: Transformers	3-4
Table 6-1: Equipment and Motors Rated in Horsepower (hp).	6-2
Table 6-2: Air Conditioning or Heat Pump Equipment Rated in BTU.	6-2
Table 6-3: Listing of Counties and Towns – Central Division	6-15
Table 6-4: Listing of Counties and Towns – Southern Division.	6-16
Table 6-5: Listing of Counties and Towns – Metro Division	6-17
Table 6-6: Listing of Counties and Towns – Palisades Division	6-17
Table 8-1: Municipalities Listed by County	8-1
Table 8-2: PSE&G Electric Distribution Division Offices	8-8
Table 9-1: Interconnection Levels.	9-3
Table 9-2: Interconnection Documents.	9-4
Table 10-1: Service Entrance Masts Specifications.	10-12
Table 10-2: Minimum Radius of Conduit Bends	10-17
Table 10-3: Handhole Drawings for Secondary Cables.	10-18
Table 10-4: Handhole Drawings for Primary Cables	10-19
Table 10-5: Acceptable Manufacturer’s Catalog Numbers of Approved Tapes	10-50
Table 10-6: Secondary Enclosure- Dimensions	10-89
Table 10-7: Maximum Number of Secondary Cables per Phase.	10-90

This Page Intentionally Blank

List of Forms

- [ED-DC-IRE-Form001](#) – Temporary Electric Service(s) Application (for a fillable form click [here](#))
- [ED-DC-IRE-Form002](#) – Permanent Electric Service(s) Load Information (for a fillable form click [here](#))
- [ED-DC-IRE-Form003](#) – Commercial/Industrial Project Contact Information Sheet (for a fillable form click [here](#))
- [ED-DC-IRE-Form004](#) – Residential Project Contact Information Sheet (for a fillable form click [here](#))
- [ED-DC-IRE-Form005](#) – Motor Data Sheet – 100 Horsepower and Above (for a fillable for click [here](#))
- [ED-DC-IRE-Form006](#) – Resistance Welder Data Sheet (for a fillable form click [here](#))
- [ED-DC-IRE-Form007](#) – Power Quality Data Sheet (for a fillable form click [here](#))
- [ED-DC-IRE-Form008](#) – Service Removal Request Application (Demolition) (for a fillable form click [here](#))

This Page Intentionally Blank

Introduction

1 Overview

The Manual Owner for the *Information and Requirements for Electric Service (IRE)* manual is Karen Campanella, Manager Business Processes. Any content questions and /or suggestions for revisions should be directed to him. The IRE manual has been established to provide an accessible and centralized repository for statements of policy, their interpretation and implementation, relative to Electric Distribution applications. It is also to provide instructions for the implementation of other procedures and for the processing of correspondence and forms where statewide uniformity is essential. It is expected that deviations from these guidelines shall have prior approval of the Manager – New Business and Work Management so that safety and consistency will be maintained.

This manual has been redesigned and revised in 2022 and replaces all previous versions. It has been updated and rewritten to include current practices, procedures, and technologies to present the information in a practical format that can be easily accessed and followed by all PSE&G personnel. It is not intended that this manual is a stand alone document, but should be complimented with Original Equipment Manufacturer's (OEM) documentation and other Technical Manuals (e.g., PSE&G *Safety Standards and Procedures* manual), as required.

2 Safety

Each Chapter of this manual incorporates worker safety in all operational procedures. All personnel working on requirements for electric service must be fully informed of all safety rules and procedures; strict adherence is mandatory.

These standards do not replace any governmental regulations, codes, or ordinances. In conforming to these standards, all Company safety standards, regulations, procedures, practices and sound judgment shall be followed.

The entire manual has been updated based on the many years of experience of key Subject Matter Experts (SME's) in Company operations, and the recommendations and requirements of recognized safety associations and authorities. Additional safety procedures will be issued from time to time – either verbally or in writing – and are to be considered an extension of the practices contained in this manual.

Since specific safety rules cannot cover all conditions that may arise on the job, each associate has a primary responsibility to follow the instructions contained in this manual, to be alert and to use good judgment for their own safety, the safety of their fellow workers and the general public. More detailed safety information can be found in the PSE&G *Safety Standards and Procedures* manual at [PSE&G OEM Document Warehouse](#).

3 New Format

A new format has been created for the Technical Manuals to:

- Make them more user friendly
- Have a consistent format across all Technical Manuals
- Create larger graphics and drawings

- Make them easier to read
- Make them compatible with our electronic requirements for posting on our website
- Make them easily adaptable to PDF files, therefore easier to search

4 Latest Version

All Technical Manuals and Procedures are available electronically and are the “**latest**” or “**most current**” version. These PDF files can be accessed 24 hours, 7 days per week at the [PSE&G OEM Document Warehouse](#) and can all be printed out. Drawings can be enlarged: they are easy to navigate through “bookmarks” on the left hand side of the page – you can just click on each chapter to take you there. You can also search them for your key interests and topics by using the **Search tool** on the top of the menu bar.

5 Updates

It is recognized that updates and/or modifications to this manual will be required as new equipment, ideas and procedures are developed in PSE&G. Such updates and/or modifications or change requests shall be initiated and approved by the Manual Owner and/or their SME’s and submitted to the Technical Documentation Group. You can also use our TechManuals@pseg.com email address to inquire about possible changes which we will direct to the Manual Owners. All users are encouraged to give their feedback on this manual and its content at any time. The Technical Documentation Department of PSE&G shall implement any and all changes only upon receipt of the approval of the Manual Owner. These changes will then be effected by revising or replacing existing pages or by issuing a bulletin to insure uniform application for appropriate associates. When new or revised pages are complete they shall be inserted in their proper places in the manuals. Notification to all applicable personnel will also take place upon approval of the Manual Owner in a prompt and timely manner. Electronic versions are found on line at the [PSE&G OEM Document Warehouse](#) and reflect our most current revisions.

The distribution of any changes is controlled by the Manual Owner and implemented by the Technical Documentation Department.

6 How to Use this Manual

Each manual consists of the following components:

- Cover page – shows the Manual Owner and Date of Release
- Record of Revisions
- Table of Contents
- Chapters
- Tabs marking the beginning of all Chapters
- List of Figures (all drawings/photographs/specifications)
- List of Tables
- List of Forms – This list provides links to PDF and fillable PDF versions of the form.
- Each page lists, in the footer, the revision date of that page (bottom left) and the Chapter/Part of the manual this page refers to (bottom right). Also, where a Section Letter was used previously instead of a

Chapter Number, this Section and Letter are indicated at the top of each page. For example Chapter 3 (old Section C) will be at the top.

- Each drawing is a specific Figure Number as is each Table. All references throughout the manual refer to these figures/tables.
- References appear in the manual in two formats:
 - a. Internal References

Internal references are references to topics that are in other locations of the *Information and Requirements for Electric Service manual*. These references list the Chapter number (if applicable) and Section number and link to the referenced material.

b. External References

External references are references to topics that are located in other manuals. These references appear in the following format:

Manual Title: Chapter Title; Section Title (if applicable); Sub-Section Title (if applicable)

Example:

Overhead Construction Outside Plant Manual: Cutouts, Surge Arrestors; 13 kV Loadbuster Disconnect Switch – 900 A Rating

- References also appear in the following format and may be internal or external references.

Reference



1. Overhead Secondary Service Run in an Overhead Zone: [Section 3](#).
2. *Overhead Construction Outside Plant Manual*: Cutouts, Surge Arrestors; 13 kV Open-Type Cutout with Loadbuster Hooks

7 Symbols

The following symbols are used throughout the manual to direct the reader to important topics.

Note



Important



Reference



Warning



Exception



Example



Danger



Caution



Warning



Use



8 What's New

The following are some of the sections that have been expanded, added or changed for this revision:

Chapter 11 – Updated Section 4.1.

9 Ownership and Confidentiality

The IRE manual is the property of PSE&G. The Manual Owner is Karen Campanella, Manager Business Processes. **It is a confidential document for PSE&G personnel only.** It is loaned to you subject to recall without prior notice, and with the distinct understanding that it is to be used only for the duration of and in connection with the performance of work for PSE&G. Reproduction in whole or in part is expressly forbidden. Should any circumstances arise under which you will no longer require this manual for the specific purpose for which it is loaned to you, it must be returned promptly. Under no circumstances shall this manual be transferred, loaned or by any-other means made available to any other individual outside the Company, firm or corporation without the express written permission of the Manual Owner.

We welcome any comments or feedback – please contact the Technical Documentation group at TechManuals@pseg.com.

Chapter 1 – General – Contents

1	Purpose	1-1
2	Clarifications	1-1
3	Definitions of Terms	1-2
3.1	Approved	1-2
3.2	Atypical Conditions	1-2
3.3	Buried Underground Distribution (BUD)	1-3
3.4	Cold Sequence	1-3
3.5	Customer	1-3
3.6	Distribution Revenue	1-3
3.7	Distribution Service	1-3
3.8	Electric Installation	1-3
3.9	Emergency Standby Generators	1-3
3.10	Energy Management or Load Management	1-3
3.11	Extension	1-3
3.12	E1 Notification	1-4
3.13	Hot Sequence	1-4
3.14	Mains	1-4
3.15	Metal Enclosed Switchgear	1-4
3.16	NRTL	1-4
3.17	Non-Utility Generators	1-4
3.18	Point of Connection	1-4
3.19	Premises	1-5
3.20	Primary Service	1-5
3.21	PSE&G	1-5
3.22	Secondary Service	1-5
3.23	Service	1-5
3.24	Service Drop	1-5
3.25	Service Entrance Installation	1-5
3.26	Service Entrance Interrupting Device	1-5
3.27	Service Run	1-6
3.28	Subtransmission Service	1-6
3.29	Tariff	1-6
3.30	Temporary Service	1-6

3.31	Transmission Service	1-6
4	Ownership, Maintenance and Removal of Apparatus Provided by or for PSE&G	1-6
5	PSE&G Responsibility for Electric Installations	1-7
6	Application for Service	1-7
7	Application for Wiring Inspection	1-8
8	Inspection and Acceptance of Customer’s Installations	1-8
9	Permits	1-9
10	Prevention of Damage to Underground Electric and Gas Facilities	1-9
11	Sealing of Meters and Devices	1-10
12	Theft of Service and Tampering	1-10
13	Pre-Requisites for Electric Service	1-10
14	Access to Customer’s Premises	1-11
15	Customer Requested Shutdown	1-11
16	Environmental Issues	1-12
16.1	Application for Service	1-12
16.2	Spill Prevention, Control and Countermeasure Plan (SPCC-40 CFR 112)	1-12
17	Customer Charges and Contributions	1-12
17.1	Extensions – General Provisions	1-12

Chapter 1 – General

1 Purpose

This publication has been issued by the Public Service Electric and Gas Company (**PSE&G**) to inform its current and prospective customers, as well as their contractors, engineers and architects, about PSE&G's specific service characteristics and installation requirements. Compliance with these service characteristics and installation requirements is necessary in order to provide for a safe working environment for both PSE&G employees and the customer, and to permit PSE&G to supply safe, adequate and reliable electric service to all its customers. In addition to these written requirements in this document, other practices and procedures may be applicable and recommended by PSE&G based upon its experience, as well as industry practice.

It is the responsibility of the customer to consult with a PSE&G representative in advance of installation (preferably at the planning stage) to determine the type of service to be supplied and to review the requirements specific to each customer's particular installation. Compliance with these requirements should help to eliminate delays in obtaining electric service and allow PSE&G to safely deliver its customer's energy needs in a timely manner.

PSE&G reserves the right to revise the information contained herein whenever PSE&G deems it appropriate. Thus, it is the responsibility of the customer, or the person responsible for the installation, to contact PSE&G prior to commencing the installation to confirm that the information relied upon in this publication is still current.

This publication is not intended to supersede the *Tariff for Electric Service* of PSE&G (PSE&G Electric Tariff), as filed with the New Jersey Board of Public Utilities (**BPU**). This document has been made a part of the PSE&G Electric Tariff by reference. The PSE&G Electric Tariff sets forth the rate schedules and the standard terms and conditions governing the supply of electric service. A copy of the PSE&G Electric Tariff is available on the PSE&G website at www.pseg.com.

The service characteristics and installation requirements set forth herein are based upon the applicable sections of the *National Electrical Code (NEC)*, the *National Electrical Safety Code (NESC)*, as well as other standards or specifications specifically referred to herein, and that are available from the American National Standards Institute, Inc. or the National Electrical Manufacturers Association.

2 Clarifications

The initial application for electric service, and any questions concerning additional matters such as rate schedules or billing should be referred to your Service Consultant at the Construction Inquiry Center.

The references made herein to any governmental authority and to any authorized agency are general. Any questions involving the application or interpretation of their requirements should be referred directly to the authority or agency involved.

Under any provision of this document, any review made by PSE&G of the customer's plans and/or specifications, any examination made by PSE&G of the actual design, construction and/or installation of the customer's equipment, and/or any determination made by PSE&G in connection with any such review or

examination will be solely for the purpose of permitting PSE&G, consistent with its statutory, regulatory and contractual obligations to its customers, to:

1. Determine whether the design, construction and installation of such facilities is compatible with the PSE&G system; and
2. Ensure that the provision of service to the customer, based on the expected use of the service, will not adversely affect the integrity, reliability or safe operation of the PSE&G system.

PSE&G's review or examination, and any determination made in connection therewith, is not intended to be, nor will same be made by PSE&G for the purpose of, nor should same be interpreted, construed and/or relied upon by the customer, or any other person or entity, as an endorsement, approval, confirmation and/or warranty of or by PSE&G relative to any aspect of the design, construction or installation of the customer's facilities, their safety, reliability, economic and/or technical feasibility, performance and/or operational capability and/or the suitability of same for their intended purpose(s). The customer shall not represent to any third-party that PSE&G's review was undertaken for any reason other than the reasons expressly stated in this publication.

3 Definitions of Terms

3.1 Approved

Refers to listed materials and methods meeting the requirements of the current editions of the NEC and the NESC, or the inspection authorities having jurisdiction, or a Nationally Recognized Testing Laboratory (NRTL) approval.

3.2 Atypical Conditions

The following are examples of, but not limited to, atypical conditions that are subject to change without notice based on operating conditions:

1. Refers to cases where underground distribution lines or service connections in overhead zones are required due to conditions beyond the control of PSE&G, or are requested by the customer and approved by PSE&G, or are required due to a local ordinance. The excess costs of such underground construction, less the estimated costs of the equivalent overhead construction, with such net costs grossed up for income tax effects, shall be paid by the customer as a non-refundable contribution.
2. Refers to circumstances where PSE&G may require customer agreements for a longer term than is specified in the Tariff, may require customer contributions toward the cost of the facilities, or may establish other charges where:
 - a. A large expenditure or special investment by PSE&G is either necessary for the supply of service, or has been requested by the customer;
 - b. Oversized transformers, feeders, or other special facilities must be installed to serve a customer whose electric service is intermittent, momentary or subject to violent fluctuations;
 - c. The electrical capacity required to serve the customer's equipment is out of proportion to its typical use of electric service for occasional or low load factor purposes, or is for short durations;
 - d. Service characteristics requested by the customer differ from those normally supplied for a similar size and type of load as specified in this manual.

3.3 Buried Underground Distribution (BUD)

Refers to the system in which the distribution lines and service conductors, with minor exceptions, are required to be buried directly in earth or in underground conduits. Requirements are governed by the *New Jersey Administrative Code (N.J.A.C.)* 14:3-8.4, *Regulation for Residential Electric Underground Extensions* of the regulations of the New Jersey Board of Public Utilities (BPU).

3.4 Cold Sequence

Refers to a meter installation where a disconnecting device is on the line side of the meter.

3.5 Customer

Is used to designate either the present or prospective user of PSE&G's electric service, and/or their designated agent, contractor, engineer or architect.

3.6 Distribution Revenue

Refers to PSE&G revenue associated only with its provision of Distribution Service, and as is calculated in Section 3.2 (f) of the *Standard Terms and Conditions of the Tariff*.

3.7 Distribution Service

Refers to a service supplied at nominal voltages of 600 V through 13,200 V.

3.8 Electric Installation

Refers to the complete electrical wiring and equipment installation at the customer's premises.

3.9 Emergency Standby Generators

Refers to generators that normally operate when PSE&G's service is unavailable, and which shall be connected in a manner approved by PSE&G. Consult your local PSE&G wiring inspector for details.

3.10 Energy Management or Load Management

Refers to a system whereby PSE&G provides customers with energy usage data.

3.11 Extension

Refers to the construction or installation of plant and/or facilities by PSE&G used to provide Service from existing or new plant and/or facilities to one or more new customers, and also refers to the plant and/or facilities themselves. An Extension also includes the Service Drop, Service Run, and any conductors, poles or supports, cable, conduit, rights of way, land, site restoration, handholes, manholes, vaults, line transformers, protection devices, metering equipment and other means of providing Service from existing plant and/or facilities to each unit or structure to be served.

An Extension begins at the existing PSE&G infrastructure, and for overhead Extensions of Service, an Extension ends at the point where the Service Drop connects to the building, or where the Jurisdictional Inspection Authority has responsibility for electrical facility inspection, but also includes the meter. In this case, the building served is the customer's facility that electrically interconnects with the PSE&G Extension. For underground Extensions, the Extension ends at, and includes, the meter unless it is impractical to place the meter at the end of the PSE&G facilities, or where the Jurisdictional Inspection Authority has

responsibility for electrical facility inspection, although in any case the meter is considered part of the Extension.

Plant and/or facilities installed to supply the increased load of existing customers are also considered an Extension where either:

1. PSE&G facilities of the required voltage or number of phases did not previously exist or;
2. Existing PSE&G facilities are upgraded or replaced due to a customer's new or additional electrical load. The new plant and/or facilities installed also must be nominally physically and electrically continuous from the beginning to the end of the Extension.

PSE&G facilities used exclusively for the purpose of providing lighting service under Rate Schedules BPL or PSAL are not considered part of an Extension.

3.12 E1 Notification

Refers to a formal request for information concerning all customer needs, that is created in PSE&G's Distribution Work Management System (**DWMS**). (Formerly referred to as an "ESI".)

3.13 Hot Sequence

Refers to a meter installation where a disconnecting device is on the load side of the meter.

3.14 Mains

Refer to the PSE&G distribution lines that are located along the streets, highways or on private property when used or intended for use for common distribution (more than one customer).

3.15 Metal Enclosed Switchgear

Refers to a metal structure containing a main switching and interrupting device and other associated equipment. A separate grounded metal compartment is required for the metering transformers, buses and connections.

3.16 NRTL

Means a Nationally Recognized Testing Laboratory, such as Underwriters Laboratories or "UL".

3.17 Non-Utility Generators

Refers to electric service customers that are privately owned generators, cogenerators or small power producers, and that operate in parallel with PSE&G's electric system. In some cases, energy may flow in either direction through the interconnection, and bi-directional meters shall be installed to meter these customers.

3.18 Point of Connection

Refers to the point where facilities installed by PSE&G are connected to the customer's facilities.

1. The point of connection for overhead secondary services is at the service head on the customer's building or structure, and adjacent to the first point of attachment of the service drop to the building or structure.

2. The point of connection for underground secondary services, including BUD from underground mains, is:
 - a. For outdoor meter locations – at the meter mounting equipment; or
 - b. For indoor meter locations – just within the building wall at the point where the service run enters the building, or at the splice box just outside the building.
3. The point of connection for underground secondary services from overhead mains is at the termination of the underground service cable on the PSE&G pole.
4. The point of connection for secondary services served from transformers on a mat or pad is the secondary terminals of such transformers, except in BUD systems.
5. The point of connection for primary, subtransmission, or transmission services will be indicated by PSE&G upon request, or when plans are submitted for approval.
6. Due to the nature of Outdoor Lighting service provided by PSE&G pursuant to Rate Schedules BPL and PSAL, there is no point of connection for such service.

3.19 Premises

Refers to a tract of land including any buildings, appurtenances and improvements thereon or any part thereof.

3.20 Primary Service

Refers to service supplied at nominal distribution circuit voltages above 600 V supplied from PSE&G's distribution system, Where the customer owns the distribution transformer and is responsible for any voltage transformers for its own secondary service requirements.

3.21 PSE&G

Refers to the Public Service Electric and Gas Company.

3.22 Secondary Service

Refers to service supplied at nominal voltages of 600 V or less.

3.23 Service

Refers to the supply of electricity to the customer.

3.24 Service Drop

Refers to the portion of an overhead service run from the last pole to the point of connection to the customer's facilities.

3.25 Service Entrance Installation

Refers to the service entrance wiring and equipment installed at the customer's premises.

3.26 Service Entrance Interrupting Device

Refers to a circuit breaker or fused load interrupter switch included as part of the Service Entrance Installation and designed to serve as:

1. A load switching mechanism to open or close a circuit under normal operation by non-automatic means; and;
2. An automatic isolating mechanism to interrupt any short circuits within the customer's installation, where such short circuits have not already been satisfactorily interrupted by other devices.

3.27 Service Run

Refers to the poles, conduits and conductors (including handholes, manholes, vaults, and transformer pads) between PSE&G mains and the point of connection to the customer's facilities.

3.28 Subtransmission Service

Refers to a service supplied at nominal voltages of 26,400 V through 69,000 V. There is some limited amount of 13,200 V Subtransmission Service still in service, but this voltage is no longer available to new Subtransmission Service customers in the PSE&G system.

3.29 Tariff

Refers to the applicable rates, schedules and electric service terms and conditions under which all service is rendered by PSE&G, and which is approved by and on file with the New Jersey Board of Public Utilities.

3.30 Temporary Service

Refers to a service intended to be used for a limited period, such as for construction, exhibition, or carnival purposes. The Temporary Service facilities will be removed at the completion of its use.

3.31 Transmission Service

Refers to service supplied at nominal transmission circuit voltages of 138,000 V and above.

4 Ownership, Maintenance and Removal of Apparatus Provided by or for PSE&G

These conditions must be followed:

1. Transformers, network protectors, meters, meter mounting equipment, instrument transformers, auxiliary metering equipment, enclosures for metering equipment, SCADA and telemetering equipment, overhead and underground lines and other appurtenances now or previously furnished by PSE&G and installed in or on the customer's premises remain the property of PSE&G. All reasonable care shall be exercised to prevent loss or damage to these facilities. PSE&G may remove this equipment when, in the opinion of PSE&G, such facilities are no longer required by the customer.
2. Under certain circumstances, it may be necessary for PSE&G to install equipment including transformers, network protectors, switches, metering equipment or other equipment including wire and cable, in or on the customer's premises and in facilities provided by the customer for PSE&G's use, including but not limited to: manholes, handholes, vaults, conduit and ductbanks. The customer is responsible for maintaining its privately owned manholes, handholes, vaults, conduit, ductbanks and similar facilities at its sole expense.

3. In the event that PSE&G will be installing oil-filled equipment on the customer's premises, the customer shall comply with the requirements shown in Section 16 of this chapter and all the pertinent environmental regulations.

5 PSE&G Responsibility for Electric Installations

PSE&G does not make new electric installations or repairs on the customer's premises beyond the "point of connection" other than on PSE&G owned equipment. Where an underground service continues through or under a building PSE&G may install wire at the customer's expense. PSE&G assumes no responsibility for the condition of the customer's electric installations, or for accidents, fires or failures that may occur as a result of the condition of these electric installations.

6 Application for Service

The following items must be reviewed by the customer as part of their application for service:

1. Before any additions, alterations or upgrades to a customer's electric service installation or equipment are made, PSE&G must be notified through your Service Consultant at the Construction Inquiry Center. All new wiring shall be installed to comply with all rules and regulations in effect at the time the additions or alterations are made. The new wiring or equipment must not be connected until such work has been approved by the inspection authority having jurisdiction. The customer shall be held solely responsible for any damage to PSE&G facilities, or customer equipment, resulting from failure to comply with this requirement.
2. In order to obtain service, the customer or his agent must contact the Service Consultant at the Construction Inquiry Center in the area where the customer's installation is located, and as far in advance of the start of construction, or date of occupancy, as possible.
3. The Service Consultant at the Construction Inquiry Center will initiate an E1 Notification, make arrangements for supply of service where necessary, furnish rate schedules, identify the type of service to be supplied, explain any special requirements and charges for the service, and verify the availability of the size of service requested. The Construction Inquiry Center will consult the local Electric Distribution Division office to confirm the type of service to be supplied to a particular location. The local Electric Distribution Division office representative will confirm the requirements for the service entrance installation and service entrance equipment with the customer.
4. Information concerning the type of service to be supplied by PSE&G, and any associated technical requirements, must be requested by the customer before making any financial commitments or purchasing electrical materials or equipment. When Metal Enclosed Switchgear is to be installed, the customer shall supply PSE&G with three sets of drawings or an electronic version to the appropriate Division's Wiring Inspection Supervisor. Drawings must include overall electric One-Line Diagram. PSE&G will not be responsible for any customer mistakes that result from a disregard of these requirements.
5. When PSE&G is requested to furnish an entire electric system to new residential buildings and mobile homes within an approved subdivision having three or more building lots, or to new multiple-occupancy buildings not more than four stories in height, this service is subject to the provisions of N.J.A.C. 14:3-8.4 et. seq., *Regulation for Residential Electric Underground Extensions* of the New Jersey Administrative Code. This Regulation provides that extensions of electric lines within such subdivisions shall be made underground. Where this Regulation is applicable, PSE&G will install a BUD system that

will normally involve a cost to the applicant, based on unit costs in the Schedule of Charges which is part of the *Tariff for Electric Service* and which is on file with the Board of Public Utilities.

6. The developer, builder or owner of the subdivision, should carefully review the requirements of the BUD Regulation prior to submitting its application to PSE&G. Refer to the N.J.A.C. for the Regulation or request how to get a copy of the BUD Regulation from the Board of Public Utilities, Two Gateway Center, Newark, New Jersey 07102.

7 Application for Wiring Inspection

In order to meet the customer's construction schedule, an "Application for Wiring Inspection," PSE&G form 432, is required **before work is started by the customer**. This form notifies the Wiring Inspection group of the local Electric Distribution Division office that the customer's proposed work is scheduled to be started. As soon as practicable, the customer shall arrange a meeting with the PSE&G Wiring Inspector at the site for the purpose of identifying the point of connection and service entrance equipment location. PSE&G will review the customer's proposed service entrance equipment for conformance with PSE&G specifications, and will furnish any other information concerning the requirements for service.

8 Inspection and Acceptance of Customer's Installations

The following items pertain to the inspection and acceptance of customer's installations:

1. Before electric service is provided, PSE&G will require a Cut-in card for the **entire** electrical installation. PSE&G will refuse to connect with any customer's installation, or make additions or alterations to the existing service connection, without receiving a certificate approving the customer's electrical installation. PSE&G may refuse to connect to any customer's installation, or make additions or alterations to the existing service connection, when it is not in accordance with the *National Electrical Code*, the *Standard Terms and Conditions* of the Tariff and PSE&G's *Information and Requirements for Electric Service*. PSE&G shall inspect the service entrance installation upon notification of its completion by the customer.

Certificates are issued by the local municipal code official; a Federal, State or County Agency; or any other agency authorized to perform such functions and services as may be designated and approved by the New Jersey Board of Public Utilities or other legislative governing entities. Authorized agencies providing certificates should be hand delivered or mailed to PSE&G. PSE&G may inspect the service entrance installation upon notification of its completion by the customer. However, to expedite service, certificates may be sent electronically to PSE&G by an authorized inspection agency. Electronically sent certificates must be followed up with the original certificate. Certificates of Approval, also known as **Cut-in cards will not be accepted from contractors or customers**.

2. It is the customer's responsibility to contact the local municipal construction code office, or other inspection authority having jurisdiction, to apply for the appropriate municipal electrical inspection. Information concerning municipal inspection fees and schedules may be obtained from the local municipal construction code office.
3. Where building alterations or rewiring make relocation of the meter and/or service drop necessary, the new location must be approved by PSE&G. The new wiring must also be approved by the inspection authority having jurisdiction before PSE&G will change the meter or relocate the service to the new location. All persons, except authorized employees or agents of PSE&G, are forbidden to remove,

relocate, or otherwise alter the PSE&G meter and its connections without prior approval from PSE&G. Attention is called to the applicable New Jersey statutes referenced in this Chapter.

4. Changes requested by the customer to the location of the existing service run, if approved by PSE&G, shall be made at the customer's expense. In the event PSE&G approves such a change in location, existing service facilities shall be utilized when they are adequate for the customer's load.

9 Permits

PSE&G will make application for any street opening permits required for installing its service connections, and shall not be required to furnish service until after such permits are granted. The customer shall be required to pay the permit fee or other charge, if any, for permission to open the street. The customer shall obtain and present without charge to PSE&G all documents providing for easements or rights-of-way, and all permits (except street opening permits), consents, and certificates necessary for the introduction of service.

10 Prevention of Damage to Underground Electric and Gas Facilities

Prior to the start of excavation or demolition, all contractors are required by New Jersey State Law to make proper notification to the One-Call Damage Prevention System, at 1-800-272-1000 or 811, to allow operators of underground facilities to temporarily locate and mark their facilities. All temporary markouts shall conform to the requirements of N.J.A.C. 14:2, "*Protection of Underground Facilities: One-Call Damage Prevention System.*" See [Figure 10.54](#) and [Figure 10.55](#) in [Chapter 10](#).

When markouts are performed by PSE&G, all underground electric markouts shall be marked with the letter designation "E" and shall be made in High Visibility Safety Red. All gas markouts shall be marked with the letter designation "G", and be made in High Visibility Safety Yellow. These colors are in accordance with ANSI Standard Z53.1, and the Uniform Color Code of the Utility Location and Coordination Council.

The following are general guidelines for markouts requested through the One-Call System:

1. Markout requests shall be made a minimum of 3 business days, but not more than 10 business days, **prior** to the start of excavation or demolition.
2. PSE&G shall complete the temporary markout of its underground facilities within 3 business days of notification by the One-Call System, and the contractor should plan accordingly.
3. The request for markout of facilities is valid for 10 business days from the date of notification. Any excavation or demolition occurring after 10 business days from the date of notification shall require a new notification.
4. The request for markout for excavation or demolition work started within the 10 business day period, is valid for 45 business days from the original request date. After the start of excavation or demolition, the contractor is responsible to protect and preserve any markout that is made by PSE&G or any other operators of underground facilities.
5. Any excavation or demolition work continuing longer than 30 business days from the original request date requires a new notification to be made by the contractor prior to the end of the original 30 business day period.

11 Sealing of Meters and Devices

All meters, and devices containing unmetered wiring, will be sealed by PSE&G. All unmetered wiring within a building shall be so enclosed as to be inaccessible. In the event that access to the sealed devices is required, the customer should contact the Wiring Inspection Department at the local Electric Distribution Division office for assistance. Attention is also called to the applicable New Jersey statute regarding theft of service issues given in the following Section.

12 Theft of Service and Tampering

In the event the customer, his agent, architect, engineer or contractor discovers one or more of the following:

1. The existence of foreign wires, conduits, cables, conductors, meters, switchgear, or other devices at or connected to the equipment of PSE&G;
2. The absence of meters or equipment that would ordinarily be expected to be present in order to accurately measure electric use;
3. That tampering with the meters or other equipment of PSE&G has occurred; and
4. In the event any of the above is discovered, theft of service should be suspected. Do not work on the equipment without first reporting the situation to the PSE&G Wire Inspector, or by telephoning **1-800-882-0145**. PSE&G will respond and further direct you on how to proceed. **If you work on equipment that has been tampered with, you may compromise your safety and risk serious injury to yourself or others.**

Tampering with PSE&G equipment and facilities is unauthorized and illegal.

If questions regarding customer obligations and liabilities regarding theft of service or tampering arise, the *Theft of Service* regulations can be found in New Jersey Statute 2C:20-8.

13 Pre-Requisites for Electric Service

The following guidelines will serve to move your project forward:

1. The customer must contact the Service Consultant at the Construction Inquiry Center as soon as practicable to determine if adequate service of the type desired is available at the customer's location. PSE&G may, under the terms and conditions of its *Tariff for Electric Service*, require from customers any of the following: deposits, service connection charges, minimum guarantees, facilities charges, easements, or other special arrangements before supplying service.
2. The customer must apply for:
 - a. An authorized agency electrical inspection at its respective location: and
 - b. A PSE&G wiring inspection at the local Electric Distribution Division office, as soon as practicable. PSE&G will not issue meter mounting equipment or any other necessary metering equipment until such applications have been made.
3. The customer must notify the local inspection authority as soon as all electrical work is completed.
4. The customer must notify the local PSE&G inspection department as soon as the service entrance installation, including grounding, is completed.

5. All PVC conduits shall be NRTL listed as approved for electrical use, otherwise the installation will not pass inspection.
6. If a pole line or underground line extension is required, any roads, streets and easement areas should be accessible and graded soon enough to permit passage and use of construction vehicles for the installation of the line facilities in advance of the required service date. If access to a pole line and/or underground line is required for installation, or for future operations and maintenance activities, and the pole line and/or underground line is not constructed along a paved area, the customer shall have an access route planned along the pole line and/or underground line that is capable of supporting heavy vehicles needed for work on the line. This route shall be paved, or have another access design that would need to be pre-approved by PSE&G as to its suitability. Curbs must be installed prior to the start of any PSE&G work.
7. Direct buried underground extensions installed by PSE&G will not be made during winter months when soils are frozen. It is vital that a developer's construction plan is coordinated with PSE&G so as to permit construction of such underground facilities during the warmer months of the year.
8. For larger projects – as detailed below – a One-Line Diagram must be accompanied by a Site Plan showing the proposed PSE&G point of service.
 - a. 4 kV or above
 - b. 800 A or above
 - c. Solar

14 Access to Customer's Premises

PSE&G must have the right of access to customer's premises, and to all equipment furnished by PSE&G, at all times for the purposes of: inspecting a customer's premises incident to the rendering of service; the reading of meters; or the inspecting, testing or repairing of PSE&G's facilities used in connection with supplying the service; or for the removal of its equipment. The customer shall obtain, or cause to be obtained, all security clearance approval permits needed by PSE&G for access to its facilities. Only authorized employees of PSE&G, or duly authorized government officials, can have access to PSE&G facilities.

For the mutual protection of the customer and PSE&G, all company employees carry identification cards, which shall be shown upon request. Under no circumstances will PSE&G employees surrender their ID or allow for their ID to be reproduced or replicated in any way.

15 Customer Requested Shutdown

Customers requesting a shutdown to their electric service shall provide PSE&G with advance notice. Please call PSE&G to determine the appropriate advance notice that is required to arrange for a shutdown and review any other requirements. PSE&G will normally disconnect the service for a customer requested shutdown without cost under the following conditions:

- PSE&G's work can be performed during normal working hours and during non-inclement weather, operating conditions permitting, or
- PSE&G's work is not within the normal work day but the shutdown can be performed by shift personnel.

PSE&G shall bill the customer for the following types of shutdowns:

- Shutdowns requiring construction crews for atypical conditions;
- Where the customer, for their convenience, requests a shutdown when the customer's work can be performed in an alternative manner not requiring a shutdown; or
- Shutdowns requested during non-normal working hours or on weekends, or shutdowns involving atypical conditions.

The customer will pay PSE&G for the shutdown cost before PSE&G performs the work. PSE&G may charge a flat rate for the shutdown or bill at a "time and material" rate for more complex shutdowns.

16 Environmental Issues

16.1 Application for Service

The customer must identify any pertinent environmental concerns related to the project, including but not limited to soil contamination or the presence of wetlands, when it makes its application for a new, relocated or upgraded service. PSE&G must be advised by the customer whether its project is, or will be, constructed upon a formerly utilized property, a "Brownfield" contaminated site, and/or a deed restricted site in either an urban or suburban area. Documentation must be presented to PSE&G regarding any and all contamination known to exist at the project site. PSE&G requires that all areas to be used for installing our facilities shall be uncontaminated.

Please note that failure to advise PSE&G of unacceptable environmental conditions, when discovered by PSE&G, may cause all site work to cease for the safety of our employees, our assigned contractors and the public, until an acceptable resolution of the issue is accomplished by the customer.

16.2 Spill Prevention, Control and Countermeasure Plan (SPCC-40 CFR 112)

1. If the customer currently has an SPCC Plan, it must be modified to meet the SPCC regulatory requirements in the event that PSE&G installs oil-filled equipment on the customer's property to serve its load.
2. If the customer is currently below the threshold for requiring an SPCC Plan, and the installation of PSE&G oil-filled equipment triggers the need for such a Plan, then the customer needs to file an SPCC Plan, and include PSE&G's oil-filled equipment as part of their application, including the design of all required engineering controls. The customer is responsible for the cost of installation of any controls required by the Plan to accommodate PSE&G's oil filled equipment.
3. If the installation of PSE&G's oil-filled equipment does not elevate the customer's facility to the level where it requires an SPCC Plan, the customer may still want to design the placement area for the oil-filled equipment using appropriate engineering controls in the event that future equipment added to the facility may require a Plan. This way the customer would avoid retrofitting controls at that time.

17 Customer Charges and Contributions

17.1 Extensions – General Provisions

Where it is necessary for PSE&G to construct an extension to serve the requirements of a customer, PSE&G may require a deposit or contribution from the customer to cover all or part of the cost of the Extension, which must be paid to PSE&G prior to any work being performed, based upon the estimated cost of the job.

See Section 3 of the *Standard Terms and Conditions of the Tariff* for further details of how such charges are determined. During construction, the charges may be increased if severe conditions such as excessive rock or other unknown conditions are found during excavation or project work.

Customers requesting service may be charged a deposit for service. The amount of such deposit will be determined by PSE&G by comparing the estimated Distribution Revenue to the applicable costs of the Extension. The detailed explanation, by customer type, of such deposits, if required, is contained in Section 3.8 of the *Standard Terms and Conditions of the Tariff*.

When it is necessary for PSE&G to construct, upgrade, or install facilities necessary to service the additional requirements of existing customer and these facilities do not meet the definition of an Extension, PSE&G may require a deposit from the customer to cover all or part of the investment necessary to supply service. Any such deposit will be calculated in accordance with Section 3.11 of the *Standard Terms and Conditions of the Tariff*.

This Page Intentionally Blank

Chapter 2 – Characteristics of Electric Service – Contents

1	General	2-1
2	Service from the Primary System	2-3
3	Service from the Subtransmission System	2-3
4	Service from the Transmission System	2-4
5	Feasibility Study Charges	2-4

This Page Intentionally Blank

Chapter 2 – Characteristics of Electric Service

1 General

The following items discuss some of PSE&G's service characteristics and practices:

1. The standard service supplied by PSE&G is alternating current with a nominal frequency of 60 Hz (cycles per second).
2. The type of service designated by PSE&G will be in accordance with its *Tariff for Electric Service* and may depend upon the facilities available at the customer's location. **Customers with computer operations or other sensitive equipment are expected to provide their own isolation equipment to protect its facility from PSE&G system voltage dips, spikes, surges and harmonics.** The manufacturers of such sensitive equipment should be consulted to determine what auxiliary devices are needed before the customer purchases computers and other sensitive equipment such as microprocessors and robotics. The customer shall insure that no harmonics or transients are introduced onto the PSE&G system due to any equipment installed at its premises. (See [Chapter 6, Section 9](#) – Voltage Sensitive Equipment of this document for more information.)
3. Customers shall typically receive the standard PSE&G service supply that is available at its location, including the number and size of circuits, type of service, capacity, location of PSE&G plant and point of connection. Where special facilities which differ from those normally supplied by PSE&G for a given size and type of load are specifically requested by the customer, these special facilities may not be considered a part of the normal facilities covered by the Tariff. If it is practical to install these facilities, such special facilities may be made available upon payment of a facilities charge or a deposit as determined by PSE&G. Such charges may be subjected to an additional tax gross-up due to their effect on PSE&G's taxable income under the provisions of the *Internal Revenue Code*.
4. If a customer specifically requests, and PSE&G agrees to supply, three-phase service for a load for which PSE&G would normally specify a single-phase service, a charge based on the amount by which these three-phase facilities exceed in cost the estimated cost of the single-phase facilities shall be billed to the customer as a charge for special facilities, without any revenue or minimum service credit. This charge, which is in addition to the usual line extension and service connection charges for single-phase service, will be based upon appropriate unit costs, including any necessary additional costs in poles, pole accessories, primary conductors, transformers, and secondary conductors. No additional charge is made for any three-phase facilities that are already available and are adequate for the customer's load.
5. PSE&G will make every effort to provide the customer with the service characteristics requested. The determination will be dependent upon various factors including the following: size and type of load, availability of the facilities, location, cost to supply the service, expected customer revenue, future plans for the area, and any special operating conditions. After considering these factors, the type of service and size of transformer to be supplied shall be determined at the discretion of PSE&G, and may differ from the customer's request. A customer contribution may be required if the projected revenue is insufficient to cover the cost of providing the requested service. The customer may also be responsible for a Feasibility Study Charge for engineering or cost estimates related to requests for a plan of supply different from that designated by PSE&G, in accordance with [Section 5](#) of this chapter.
6. Three-phase service is susceptible to a phenomenon known as single-phasing, due to the interruption of one or two phases of the three-phase supply. This condition may be caused by any number of factors in the utility system or the customer's wiring, including single-phase to ground faults, wires down due to

storms, vehicle pole hit accidents, or blown fuses. Under certain limited circumstances, three-phase customers may receive sustained low voltage on one or two phases until normal service can be restored. The customer's equipment shall be suitable or adequately protected to accept this type of service.

7. For real estate developments, or for several customers in the same general area who apply simultaneously, the principles given in paragraphs 3 and 4 above are applied to the individual customers to determine the type of service to be specified. The total charge, if any, is then made to the developer or allocated among the individuals in the same manner as similar charges for line extensions.
8. Any transformation of the service voltage shall be done by and at the customer's expense.
9. Where applicable, PSE&G recommends that the customer consider specifying motors that operate at 240 or 480 V rather than 208 V due to improved motor operation, particularly if the customer's load is principally electrically powered, or if long runs of wiring are involved. For 208 V services, resistance heating appliances such as ranges and water heaters should be equipped with coils rated at 208 V for satisfactory operation.
10. Services must be grounded when required by the *National Electrical Code*, State or municipal authorities, or when the service available is of the grounded type.
11. The types of services supplied by PSE&G are shown in [Table 2-1](#). kVA guidelines shown are subject to a separate determination in each case. The customer shall design its equipment bracing based upon its maximum service size, not its connected load. For non-standard sizes, such as services for cell tower sites, DOT installations, pumping stations, or non-residential pools, the customer shall discuss the application with PSE&G. Secondary connections to PSE&G transformers 500 kVA and above shall be in accordance with [Chapter 10](#), [Table 10-7](#).
12. PSE&G will furnish the appropriate transformers for supplying secondary customers in overhead zones. Such transformers will be one of the following types:
 - a. Pole-mounted
 - b. Pad-mounted located at the customer site; or
 - c. Located in a customer-furnished exterior vault

Unless extenuating conditions exist at the customer's site that preclude using all of the above listed options, submersible-type transformers and transformer installations in interior vaults shall not be used for providing service to secondary customers in overhead radial distribution zones. This policy is based upon higher equipment installation and maintenance costs, poor accessibility, reduced reliability and longer outage restoration times associated with this type of equipment. PSE&G has sole discretion on whether to install submersible transformers, or to place transformers in interior vaults.

Table 2-1: Recommended Secondary Service kVA Demands

Type of Service	Volts	Maximum Service Size	Overhead/Underground Service	Pad Mounted Transformer	Underground Network
Single-Phase, Two-Wire	120	30 A	3.6 kVA max	3.6 kVA max	3.6 kVA max
Single-Phase Three-Wire	120/240	400 A*	100 kVA max	167 kVA max	N/A
Single-Phase Three-Wire	120/208	200 A	20 kVA max	20 kVA max	20 kVA max
Three-Phase, Four-Wire	120/240	400 A*	15-150 kVA	N/A	N/A
Three-phase, Four-wire	120/208	4000 A	55-300 kVA	150-1500 kVA	20 kVA min
Three-Phase, Four-Wire	277/480	4000 A	55-300 kVA	150-3000 kVA	1000-3000 kVA

Note: *Normally for 120/240 V service the maximum service size is 400 A. Under certain operating conditions, permission may be granted for installation of 600 A service equipment for an individual 120/240 V load. Consult the local Electric Distribution Division office for requirements.

2 Service from the Primary System

PSE&G will supply service at a nominal 4,160 V or nominal 13,200 V, three-phase, four-wire as required, where available and as warranted by the conditions specified in [Table 2-2](#). Although the supply may initially be furnished at a nominal 4,160 V, service and transforming facilities shall be designed for future operation at a nominal 13,200 V. The customer shall design its service entrance facilities, cables, switchgear and transformers to take the eventual conversion from 4,160 V to 13,200 V into account; the customer is also responsible for the installation of any billing metering equipment required. PSE&G will provide the customer with an estimated time for when such conversion is scheduled, if known at the time service is requested. Such service will not be supplied from a distribution circuit that supplies only secondary network load.

3 Service from the Subtransmission System

PSE&G will supply service at a nominal 26,400 V, three-phase, three-wire, where available and warranted by the conditions specified in [Table 2-2](#). In certain restricted areas this supply may be at a nominal 13,200 V initially, but service and transforming facilities shall be designed for future operation at a nominal 26,400 V. Such service will not be available from 26,400 V circuits supplying a secondary network.

PSE&G will supply service at a nominal 69,000 V, three-phase, three-wire, where available and warranted by conditions specified in [Table 2-2](#). In certain restricted areas this supply may be at nominal 26,400 V initially, but service and transforming facilities shall be designed for future operation at a nominal 69,000 V. Such service will not be available from 69,000 V circuits supplying a secondary network.

4 Service from the Transmission System

PSE&G will supply Transmission Service at a nominal 138,000 or 230,000 V, three-phase, three-wire or four-wire, for very large loads or where required by special conditions. PSE&G may require that service and transforming facilities installed for a nominal 138,000 V service be designed for future operation at 230,000 V.

Table 2-2: Recommended Primary, Subtransmission and Transmission Service kVA Demands

Type of Service	Volts	Levels of Demand
Three-Phase, Four-Wire	4,160	500 - 3,000 kVA
Three-Phase, Four-Wire	13,200	500 - 5,000 kVA
Three-Phase, Three-Wire	26,400	3,000 - 30,000 kVA
Three-Phase, Three-Wire	69,000	over 3,000 kVA
Three-Phase, Three-Wire	138,000	over 30,000 kVA
Three-Phase, Four-Wire	138,000	over 30,000 kVA
Three-Phase, Three-Wire	230,000	over 30,000 kVA
Three-Phase, Four-Wire	230,000	over 30,000 kVA

5 Feasibility Study Charges

The following are general requirements for feasibility studies:

1. A Feasibility Study Charge may be charged to a customer for engineering or cost estimates when that customer requests a plan of supply different from that designated by PSE&G.
2. Authority to establish such charges is in Section 3.3 - Atypical Operating Conditions, of the *Standard Terms and Conditions of the Tariff*.
3. Upon a customer request for service to a new or additional load, PSE&G will determine the preferred method of serving that load, including designation of the electric service voltage.
4. If the customer requests a plan of supply different from that designated by PSE&G, PSE&G will initially provide up to 10 person-hours of cost estimating resources at no charge to the customer. These resources will be used to provide one or more conceptual estimates (also known as “office estimates”) of the total job, and the amount of the customer contribution required, if any. The customer should be aware that these estimated costs may vary significantly from more detailed engineering cost estimates.
5. If the customer requests a more detailed engineering cost estimate (also known as a “budget estimate”) for an alternate supply plan, the customer shall be required to furnish PSE&G a deposit in the amount of \$10,000 from which the costs to develop the estimate will be charged. Any unspent funds remaining from this deposit will be returned to the customer at the completion of the detailed cost estimate.
6. For extremely large, complex, or unusual projects or requested changes in supply plans, the local Electric Distribution Division office may increase the amount of the deposit required for providing a detailed engineering cost estimate.

7. In those cases where a Feasibility Study Charge is applicable (i.e. beyond the first 10 person-hours of labor), it will include the cost of all engineering and design labor, outside services, supervision, overheads and office costs (drawings, printing services, telephone, etc.). The charges shall not include the planned cost of electric distribution equipment or supplies not yet purchased (such as transformers, conductors or poles) or field preparation work not yet performed (such as trenching and safety mark outs).
8. Once PSE&G has begun constructing a service (either the original or another alternate plan of supply), the customer, in addition to any additional Feasibility Study Charges for the alternate supply plan, shall be responsible for any PSE&G costs or expenses related to the original supply plan that cannot be utilized in the requested revisions, and all equipment purchased by PSE&G that cannot reasonably and timely be used for the supply to other customers, and any field preparation work already performed.
9. Customer payment of any Feasibility Study Charges, or refunding of such unused portion of a customer deposit, shall have no impact on any other customer contribution required related to supplying service including those for: temporary services; any requested special equipment; excess facilities required as a result of the application of either the electric Line Extension and Service Connection policy; or any other customer contributions or deposits required by PSE&G.

This Page Intentionally Blank

Chapter 3 – Service Runs – Contents

1	General	3-1
2	Temporary Services	3-2
2.1	Charges and Rates	3-3
2.2	Unit Fixed Charges for Installation and Removal of Temporary Services	3-3
3	Overhead Secondary Service Run in an Overhead Zone	3-4
4	Underground Secondary Service Run in an Overhead Zone	3-5
5	Residential Buried Underground Distribution (BUD) Systems	3-6
6	Secondary Service Runs in an Underground Zone	3-6
7	Overhead Primary Service Runs in an Overhead Zone	3-7
8	Underground Primary Service Runs in an Overhead Zone	3-7
9	Primary Service Runs in an Underground Zone	3-8
10	Padmounted Transformer Installations – Secondary Metered	3-8
11	Transformer Vault Installation – Secondary Metered	3-9

This Page Intentionally Blank

Chapter 3 – Service Runs

1 General

The following items discuss PSE&G's policies and procedures for service runs:

1. "Service Run" refers, in general, to the necessary poles, conduits, and conductors (including manholes, handholes, vaults, and transformer pads) between the PSE&G mains and the point of connection to the customer's facilities. In accordance with the Tariff, the customer will be required to pay a contribution for any excess costs resulting from additional facilities required to provide service. Refer to the Tariff for the current policy and formulas to determine whether excess costs exist.
2. The local PSE&G Electric Distribution Division office will designate the type of service run to be employed, the exact location of the point of connection with the customer's facilities and the characteristics of the service to be supplied. **The customer shall contact the local PSE&G division wiring inspector prior to the start of work to determine the requirements for the service entrance installation.** PSE&G will give due consideration to appearance, accessibility and reasonable customer requests, but the ultimate choice of location for the service connection shall be at the sole discretion of PSE&G.
3. Except as otherwise specified herein, PSE&G will construct all service runs from its mains to the "point of connection". The PSE&G Service Consultant will inform the customer of any applicable customer contributions or deposits.
4. All cables and conduit installed under, within, or otherwise attached to the building will be at the customer's expense. PSE&G will not be responsible for the maintenance of conduit or cable under, within or otherwise attached to the building.
5. Primary distribution, subtransmission and transmission service runs to outdoor structures of the open type, may be made by means of overhead wires. PSE&G approval for this type of service run must be obtained before planning the installation. PSE&G will perform all work (poles, wires and appurtenances) up to the point of connection to the customer's facilities.
6. Electric Service will be supplied to a building through a single service run except where, in the sole judgment of PSE&G, special conditions require the installation of more than one service run. Written approval of the electrical inspection authority having jurisdiction is required if more than one service is to be supplied to a single building.
7. Groups of buildings on a single piece of property and under common ownership should be supplied from a single service run. Where such buildings each have suitable provisions for service facilities, they may be supplied separately at the discretion of PSE&G. The service to each customer at each service location will be metered and billed separately.
8. The customer is responsible for all modifications resulting from changes in conditions impacting the customer installation, such as structural deterioration, unstable soil conditions, grade changes, etc. Any relocation of PSE&G facilities may require a customer contribution.
9. If a customer in an underground zone has landscaping or hardscaping in the area of the route for the underground service run, and the installation of the service run would require disturbing the landscaping or hardscaping, the customer shall be responsible for the restoration costs. The customer may choose to perform the restoration work itself, or to be billed for the work by PSE&G. If this is an underground service in an overhead zone, then the customer is responsible for bringing any necessary buried cables,

conduit or ductbank to the curb line or to some other point away from such landscaping or hardscaping, and which is acceptable to PSE&G.

10. If the customer, for whatever reason, is responsible for installing any underground service runs, and such service runs are **not** encased in concrete, and are buried 18 in. or more below grade, such service runs shall have their location identified by a red warning ribbon that shall be placed in the trench at least 12 in. above the underground installation. This ribbon shall be of the “detectable” type, be at least 3 in. wide, and shall state “**Caution Buried Electric Line Below**” (Ideal 42-201 or similar product). Tape shall be visible at the exit points of the service from the ground, where practicable. (See [Section 8](#) in [Chapter 10](#)).

2 Temporary Services

The following are general requirements for temporary services:

1. Where service is to be used at a premises for a limited period of time, and such installation is not permanent in nature, the customer’s use of the service shall be classified as “Temporary”. The customer will be required to pay up front for the cost of installation and removal of any temporary facilities required, prior to PSE&G’s installation of the service. Temporary service is only furnished under PSE&G’s GLP, LPL or HTS commercial tariffs, and is not available for any lighting service tariffs.
2. Temporary service is further described as follows:
 - Where the overhead service drop is 100 ft or less and no additional facilities are required to provide service, the customer shall pay a flat fee for the temporary service plus the charge for energy used at the applicable rate. (See [Section 2.1](#) – Charges and Rates.)
 - If the overhead service drop is more than 100 ft in length, or if any additional facilities are required to provide service, the customer shall pay the flat fee noted in [Section 1](#) above plus the cost of installation and removal of such additional facilities plus the charge for energy used at the applicable rate.
 - Where an underground service extension is 10 ft or less from PSE&G’s designated supply point with the PSE&G electric system, the customer shall pay a flat fee for the temporary service as in [Section 1](#) above, and the customer is responsible for furnishing and installing all underground temporary service facilities up to the PSE&G designated supply point. The last 2 ft of any underground installation shall be excavated by PSE&G, and the customer shall leave enough service wire coiled up for PSE&G to terminate the wire on its facilities. (See [Section 2.1](#) – Charges and Rates.)
 - At the sole discretion of PSE&G, underground temporary service lengths may exceed this 10 ft limitation due to site conditions. For any underground installations in excess of 10 ft from the PSE&G designated supply point, the customer shall pay the flat fee noted in (a) above plus the costs of installation and removal of such additional facilities plus the charge for energy used at the applicable rate.
3. The customer’s terminal and intermediate support installations for receiving temporary service shall maintain *National Electrical Safety Code* and appropriate governmental agency clearances, be structurally safe and provide an adequate support for the point of attachment.
4. Overhead temporary service mast - The customer shall furnish a service mast with a PSE&G-approved meter board/socket as shown in [Chapter 10, Figure 10.47](#). PSE&G will not attach a service to any structure that does not meet PSE&G specifications. Temporary overhead service masts shall be placed at a location designated by PSE&G.

5. Underground temporary service mast/pad – The customer shall furnish a service mast with a PSE&G-approved meter board/socket as shown in [Chapter 10, Figure 10.48](#). PSE&G will not attach a service to any structure that does not meet PSE&G specifications. Temporary underground service masts should be located within 10 ft of the designated pad mounted transformer or secondary enclosure. The customer shall dig a service trench and install the service wire to within 2 ft of PSE&G’s supply point in accordance with [Figure 10.48](#). Buried temporary service runs shall adhere to the requirements of [Section 1](#) paragraph 10. above.
6. When the temporary service design requires additional construction work not included in the flat fee charges listed below, and as described in [Section 2](#), paragraph 2. above, the customer will be billed PSE&G’s costs for the excess work required. The material cost of transformers, 26 kV pole top switches, cutouts, meters, lightning arresters (line or transformer) and any other protection or voltage regulating equipment shall not be charged to the customer. However, the labor charges for installing and removing these items shall be charged, and in addition, any other costs for materials and appurtenances needed to install these items shall be charged to the customer.
7. **Temporary service meters shall not be relocated from the originally designated service location.** The PSE&G Service Consultant must be contacted to initiate work to remove the temporary meter and service.

2.1 Charges and Rates

All temporary service flat fees are based on the following tables. A job that does not fit the parameters defined shall be estimated and then billed at actual cost. The charges listed in the tables below may be changed from time-to-time. Please check with PSE&G for the latest changes.

2.2 Unit Fixed Charges for Installation and Removal of Temporary Services

Table 3-1: Service Drop and Meter

	Installation	Removal	Total
100 A, single-phase service	\$310.00	\$140.00	\$450.00
200 A, single-phase service	\$440.00	\$190.00	\$630.00
400 A, single-phase service	\$610.00	\$230.00	\$840.00
200 A, three-phase service	\$520.00	\$230.00	\$750.00
400 A, three-phase service	\$810.00	\$260.00	\$1,070.00
Note: For parallel service drops, double the above costs. Customer to supply CT cabinet and install CT's furnished by PSE&G.			

Table 3-2: Transformers

	Installation	Removal	Total
25 kVA single-phase	\$440.00	\$200.00	\$640.00
50 kVA single-phase	\$460.00	\$200.00	\$660.00
100 kVA single-phase	\$670.00	\$210.00	\$880.00
3-25 kVA three-phase	\$1,150.00	\$860.00	\$2,010.00
3-50 kVA three-phase	\$1,220.00	\$860.00	\$2,080.00
3-100 kVA three-phase	\$1,940.00	\$910.00	\$2,850.00
Note: Removal cost includes credit for salvage. Above charges are for all voltages and classes of transformers.			

3 Overhead Secondary Service Run in an Overhead Zone

The following are general requirements for overhead secondary service runs in an overhead zone:

1. For overhead secondary service runs in an overhead zone, PSE&G will perform all work (wires, poles and appurtenances) from its mains to the point of connection to the customer’s facilities. The customer shall install the necessary service entrance equipment up to and including the service head in accordance with the provisions of [Chapter 4](#).
2. It is the customer’s responsibility to provide suitable support for the attachment of a service hook for the service, and to install the service hook at the designated location per the local PSE&G wiring inspector. This support and hook must be capable of withstanding the pull of the service drop conductors.
3. PSE&G will furnish and install the new entrance facilities from its mains in the street to the curb for conduits, and just inside the foundation wall for cables.
4. For wire markings on four-wire Delta connections, only the High Leg is marked with orange tape and the neutral with white tape (120/240 three-phase four-wire). On 277/480 V and 120/208 V three-phase four-wire service installations, only the neutral needs to be marked with white tape. If parallel conductors are used, the contractor may color code the conductors to identify the phases. There shall be no orange or green color coding tape used on phase conductors. Orange color conductors or coding tape shall be strictly limited to identifying 120/240 V three-phase four-wire delta services.
5. The following sections and applicable drawings are included in [Chapter 10](#) of this manual:
 - [Section 1](#) – Service Entrance Clearances
 - [Section 2](#) – Grouped Meter Mounting Equipment Specifications
 - [Section 4](#) – Unacceptable Service Location
 - [Section 5](#) – Indoor Enclosure Overhead Secondary Service
 - [Section 6](#) – Service Entrance Mast – Galvanized Rigid Steel Conduit
 - [Section 7](#) – Service Entrance Installations
6. The service point of attachment shall be directly accessible from a ladder placed on the ground.

4 Underground Secondary Service Run in an Overhead Zone

The following are general requirements for underground services in overhead zones:

1. When a customer's load requirements can be supplied from overhead secondary facilities, and the customer requests an underground secondary service, the customer shall furnish and install the service conductors, to extend 3 ft or more beyond PSE&G's secondary mains or transformer connections on the pole, and install any necessary conduit at its own expense, and in accordance with the provisions of [Chapter 4](#). PSE&G will connect the service conductors to the PSE&G mains or transformer, and will thereafter maintain the service facilities without charge to the customer. PSE&G will not replace a customer-installed conduit and/or cable for increased load requirements, damage due to overload conditions, settlement or terrain changes, or other natural circumstances.
2. When a customer's load requirements can be adequately supplied from overhead secondary facilities, but where underground service is required due to operating reasons beyond the control of PSE&G, the customer will furnish and install the service conduit run at its expense and in accordance with PSE&G specifications. PSE&G will furnish and install the entrance facilities from its mains in the street to the curb for conduits, and just inside the foundation wall for cables. PSE&G will thereafter maintain the service conductors at no charge to the customer. PSE&G will not replace a service conductor for increased load requirements, damage due to overload conditions, settlement or terrain changes, or other natural circumstances.
3. Where overhead mains are on the opposite side of the street from the customer, an overhead street crossing will be provided by PSE&G. The customer shall furnish and install all secondary service conductors with sufficient length to reach the PSE&G secondary mains or transformer on the pole. If an overhead crossing is impracticable or otherwise undesirable, PSE&G will install an underground crossing at the customer's expense, and a handhole or manhole in the sidewalk area on the customer's side of the street, if required. If approved by PSE&G, the customer may install this street crossing and the handhole or manhole itself. The customer shall furnish and install all conduit and secondary service conductors up to such handhole or manhole, with sufficient conductor length supplied to allow for splices.
4. Underground service runs, when installed according to applicable *National Electrical Code* requirements, may be placed in the same trench with gas, telephone and/or cable television, and with approval from the appropriate utility. There shall be a minimum of 12 in. of earth separation between the electric cables or conduit and any other subsurface utilities such as gas, telephone or cable. Electrical conduit shall not be cast in the same concrete envelope with any other subsurface pipes. (See [Chapter 10, Section 10, Item 16](#).)
5. The customer shall consult the local Electric Distribution Division office to determine the correct type of installation required for underground services. The customer may be required to furnish and install a PSE&G-approved handhole where services exceed 150 ft. The normal installation practice is to use conduit, and any direct buried installations must first be authorized by the local Electric Distribution Division office.
6. Where a customer's load requirements make it impractical to supply underground service from overhead secondary facilities, a pad mounted transformer installation will be required. The customer shall furnish and install at its expense, and in accordance with PSE&G specifications, the primary conduits and any necessary manholes, which will be maintained by PSE&G. The customer shall also be required to furnish, install and maintain all secondary conduits and conductors and provide space on its property for the necessary transformation equipment. PSE&G will furnish and install the entrance facilities from its mains in the street to the curb for conduits, and just inside the foundation wall for cables.

7. For wire markings on four-wire Delta connections, only the High Leg is marked with orange tape and the neutral with white tape (120/240 three-phase, four-wire). On 277/480 V and 120/208 three-phase four-wire service installations, only the neutral needs to be marked with white tape. If parallel conductors are used, the contractor may color code the conductors to identify the phases. There shall be no orange or green color coding tape used on phase conductors. Orange color conductors or coding tape shall be strictly limited to identifying 120/240 three-phase four-wire delta services.
8. When the customer installs any underground service runs, and such service runs are **not** encased in concrete, and are buried 18 in. or more below grade, such service runs shall have their location identified by a red warning ribbon that shall be placed in the trench at least 12 in. above the underground installation. This ribbon shall be of the “detectable” type, be at least 3 in. wide, and shall state “**Caution Buried Electric Line Below**” (Ideal 42-201 or similar product). Tape shall be visible at the exit points of the service from the ground, where practicable.
9. Direct buried underground extensions installed by PSE&G will not be made during winter months when soils are frozen. It is vital that a developer’s construction plan is coordinated with PSE&G so as to permit construction of such underground facilities during the warmer months of the year.
10. The customer shall install an expansion fitting below the meter pan and above grade for any underground service run.

5 Residential Buried Underground Distribution (BUD) Systems

The following are general requirements for Residential Buried Underground Distribution System (**BUD**) Systems:

1. Where a Buried Underground Distribution (**BUD**) system must be provided in residential areas in accordance with N.J.A.C. 14:3-8.4, “*Regulation for Residential Electric Underground Extensions*”, one of the utilities involved will normally perform all trenching work, although in some cases the customer may do the trenching. Cable installation, backfilling, transformer pads, services, etc. from PSE&G’s system to the point of connection to the customer’s facilities, will be performed by PSE&G subject to the provisions that are included in the Regulation, and the charges in the Tariff.
2. Rough grade must be within 6 in. of final grade before any trenching work will be performed. Any subsequent changes to installed PSE&G facilities due to changes in this grade will be made by PSE&G at the customer’s expense.
3. The customer is responsible to clear debris or for any other work necessary to facilitate installation of underground facilities. At our discretion, PSE&G will charge on a time and material basis.
4. Direct buried underground extensions installed by PSE&G will not be made during winter months when soils are frozen. It is vital that a developer’s construction plan is coordinated with PSE&G so as to permit construction of such underground facilities during the warmer months of the year.
5. The developer will provide approved site, lighting, and drainage plans at the time of request for electric service.

6 Secondary Service Runs in an Underground Zone

The following are general requirements for secondary service runs in an underground zone:

1. For secondary service runs in an underground zone, PSE&G will furnish and install the entrance facilities from its mains in the street to the curb for conduits, and just inside the foundation wall for cables. If

approved by PSE&G, the trenching work for the service run may be performed by the customer. In the event that the customer has landscaping or hardscaping that would be disturbed by PSE&G while installing the service run, the customer shall be responsible for restoration costs in accordance with [Chapter 3, Section 1](#), paragraph 9.

2. Normally, underground extensions installed by PSE&G will not be made during winter months when soils are frozen. It is vital that a developer's construction plan is coordinated with PSE&G so as to permit construction of such underground facilities during the warmer months of the year.
3. Under certain circumstances in an Underground Zone, where a service is connected to a network system, service mains up to 800 A may require a breaker or fused disconnect switch immediately after the point where the service conductors enter the customer's building. If required, this equipment must have provisions to accommodate a standard seal and barrel lock. For services over 800 A, additional facilities will be required to accommodate PSE&G current limiting equipment. See [Figure 10.51](#) in [Chapter 10](#) this document. Customer should contact the local Electric Distribution Division office to obtain the specifications for a service to be connected to a network system prior to beginning any work.
4. A pull box may be required to accommodate conduits entering the building, depending on the size of the service. Contact the wire inspector to determine size of the pull box necessary, that becomes the point of connection.

7 Overhead Primary Service Runs in an Overhead Zone

For overhead primary service runs in an overhead zone, PSE&G will furnish, install and maintain all poles and primary service conductors between its mains and the point of connection to the customer's facilities. The installation of any conduit runs will be at the customer's expense. PSE&G will furnish and install the entrance facilities from its mains in the street to the curb for conduits, and just inside the foundation wall for cables.

8 Underground Primary Service Runs in an Overhead Zone

The following are general requirements for underground primary service runs in an overhead zone:

1. Where an underground primary service run in an overhead zone is requested by the customer and approved by PSE&G, the customer shall furnish and install at its expense the necessary conduits, manholes and handholes according to PSE&G specifications. PSE&G will furnish and install the entrance facilities from its mains in the street to the curb for conduits, and just inside the foundation wall for cables. In the event that the customer has landscaping or hardscaping that would be disturbed by PSE&G while installing the service run, the customer shall be responsible for bringing its connection point out to the curb or past such improvements in accordance with [Chapter 3, Section 1](#), paragraphs 9. and 10.
2. Where overhead mains are on the opposite side of the street from the customer, an overhead street crossing is preferred by PSE&G. If the customer requests an underground crossing, or an overhead crossing is impractical or cannot be constructed, PSE&G will install the crossing underground with any required manholes and handholes, at the customer's expense. Alternatively, the customer may install the street crossing in accordance with PSE&G specifications, and an approved PSE&G contractor must obtain PSE&G's inspection approval before backfilling the trench. PSE&G will furnish and install the primary service cable.

3. The customer shall consult the local Electric Distribution Division office prior to starting any work in order to determine the type of installation required for underground services. The normal installation will be in conduit. Authorization for a direct buried cable installation must come from the local Electric Distribution Division. (See [Chapter 10, Section 10](#) – Specifications for Customer-Installed Underground Service Conduit – Overhead Zone)
4. Normally, underground extensions installed by PSE&G will not be made during winter months when soils are frozen. It is vital that a developer's construction plan is coordinated with PSE&G so as to permit construction of such underground facilities during the warmer months of the year.

9 Primary Service Runs in an Underground Zone

For primary service runs in an underground zone, PSE&G will furnish and install the entrance facilities from its mains in the street to the curb for conduits, and just inside the foundation wall for cables. If approved by PSE&G, the trenching work may be performed by the customer. In the event that the customer has landscaping or hardscaping that would be disturbed by PSE&G while installing the service run, the customer shall be responsible for the restoration costs in accordance with [Chapter 3, Section 1](#), paragraph 9.

Normally, underground extensions installed by PSE&G will not be made during winter months when soils are frozen. It is vital that a developer's construction plan is coordinated with PSE&G so as to permit construction of such underground facilities during the warmer months of the year.

10 Padmounted Transformer Installations – Secondary Metered

The following are general requirements for padmounted transformers:

1. For padmounted transformer installations in overhead zones (non-residential BUD), the primary and secondary wiring to the transformer pad must be installed underground. PSE&G will provide and install the pad and the padmounted transformer, and will install and connect the primary conductors to the transformer. The customer shall do the site preparation work to accept the transformer pad, and furnish and install at its expense the necessary conduits and any manholes required, in accordance with PSE&G specifications. For direct buried cable installations where allowed, the customer shall furnish and install at its expense, and in accordance with PSE&G specifications, the trench, the sand required for protection of the cables, warning tape, backfilling, and any conduits as required by PSE&G from the transformer pad to the selected pole. All work on the secondary side of the transformer, including the connections to the transformer terminals, is the customer's responsibility. **Secondary conductors shall not be installed until the transformer has been set on the pad.** The customer shall not be permitted to run a separate grounding conductor between the customer's premises and the PSE&G transformer.
2. For padmounted transformer installations in underground zones, the primary wiring to the transformer pad must be installed underground by PSE&G in accordance with the Tariff. The customer will install and connect the secondary conductors to the transformer. The customer shall furnish and install at its expense and in accordance with PSE&G specifications, the primary conduits and any necessary manholes from the transformer pad to the selected PSE&G manhole, and all work on the secondary side of the transformer including the hardware required to make connections to the transformer terminals, and the connections themselves. **Secondary conductors shall not be installed until the transformer has been set on the pad.** The customer shall not be permitted to run a separate grounding conductor between the customer's premises and the PSE&G transformer.

3. In those cases where the connections to the transformer would normally be made by the customer at its own expense, PSE&G may elect, in special cases, to do such work with its own forces on a time and material basis at the customer's expense.
4. The customer must assure ready access to the transformer installation in a manner that will make certain the easy and expeditious delivery, removal and maintenance of the transformers and associated equipment. The pad shall be accessible for inspection, and for installing and replacing the transformer, including driving heavy equipment over to it without damage to the landscaping or the equipment. Access design must be approved by PSE&G. (See [Figure 10.38](#) in [Chapter 10](#)).
5. The maintenance for all single-phase and three-phase padmounted transformer secondary service facilities is the customer's responsibility.
6. The customer must consult the local Electric Distribution Division to determine if soil conditions may require the entire service run to be placed in conduit.
7. All PVC conduit shall be NRTL listed and approved for electrical use, Schedule 40 or 80 as required. See [Chapter 10, Section 10](#), and check with the local Electric Distribution Division to determine what Schedule type is applicable.

11 Transformer Vault Installation – Secondary Metered

The following are general requirements for transformer vaults:

1. In underground zones where the customer's load is greater than that which can be supplied from the secondary mains, PSE&G will construct transformer manholes in the street or sidewalk area, or may construct transformer manholes on private property exterior to the customer's building, and where 24 hour access is available. The equipping and wiring of such manholes will be done by and at the expense of PSE&G. If the construction of transformer manholes outside of the building is impractical, the customer must provide a transformer vault at his building in which PSE&G will set the transformers. If this vault is exterior to the building, PSE&G will wire the vault on both the primary and secondary sides. An exterior vault includes one that, even though it may be physically within the confines of the building, can only be entered from a point exterior to the building.
2. In overhead zones where the customer chooses to have a transformer vault installation, or where physical limitations require such an installation, PSE&G will set the transformers in place in a vault furnished by the customer provided it is at ground level and accessible. If the vault is exterior to the building, PSE&G will connect to the transformer on the primary side. The customer will provide all material and work on the secondary side of the transformers, including connections to the transformer terminals. The number of secondary sets cannot exceed 10 and a full neutral must be provided. An exterior vault includes one that, even though it may be physically within the confines of the building, can only be entered from a point exterior to the building.
3. Where 277/480 V network service is provided, a bus room in a permanently dry location within the customer's building is required. The bus room must be located adjacent, on the same level no more than 50 ft from the transformers.
4. For a 277/480 V network service, PSE&G will furnish the collector bus. The installation of the collector bus in the bus room shall be by and at the expense of the customer. The local Electric Distribution Division must be consulted to obtain the specific requirements for such an installation.

5. In those cases where the connections to the transformer would normally be made by the customer at their expense, PSE&G may elect, in view of the specialized connections to be made, to do such work with its own forces and at the customer's expense.
6. The customer must assure ready access to the transformer installation in a manner that will make certain the easy and expeditious delivery, removal and maintenance of transformers and associated equipment. The vault shall be accessible for inspection, and for installing and replacing the transformers, including driving heavy equipment over to external vaults without damage to the landscaping or the equipment. Access design must be approved by PSE&G.
7. The customer's vault construction shall be in accordance with the provisions of the authority having jurisdiction, PSE&G requirements and the current edition of the *National Electrical Code*.

Chapter 4 – Service Entrance Installations – Contents

1	General	4-1
2	Grounding	4-2
3	Secondary Service Entrance Installations for Overhead Connection from Overhead Mains.	4-2
4	Secondary Service Entrance Installations for Underground Connection from Overhead Mains.	4-3
5	Secondary Service Entrance Installations for Connections from Underground Mains.	4-4
6	Secondary Distribution Service Equipment	4-5
7	Specifications for Primary Service.	4-6
8	Requirements for Switchgear Review	4-6
9	Non-Utility Generators (NUGs)	4-7

This Page Intentionally Blank

Chapter 4 – Service Entrance Installations

Note



For on-time electric service:

- Apply for meter installation as early as possible, but no less than 6 to 8 weeks in advance of the necessary service date.
- Before beginning work, apply with your local inspection agency and for a **PSE&G wiring inspection** (PSE&G form 432).
- After the local inspection Certificate of Approval is received and PSE&G inspection is complete, service will be connected without delay.

1 General

The following general requirements apply to service entrance installations:

1. Except as otherwise provided herein, the customer shall furnish and install the service entrance equipment on the premises.
2. PSE&G will install the revenue meters, test switches and other directly associated metering equipment. PSE&G will furnish the metering transformers for installation by the customer in a manner approved by PSE&G. The type, of which, will be determined by PSE&G.
3. All service entrance equipment shall be of a type accepted by PSE&G and shall be installed according to the requirements of all federal, State, county and municipal authorities having jurisdiction, PSE&G requirements, and the current editions of the *National Electrical Code* and the *National Electrical Safety Code*. The location of the point of connection and the type of metering equipment will be provided by PSE&G.
4. Connections made ahead of the main service equipment for emergency equipment such as fire pumps, exit lights, and emergency control power shall only be made where specifically accepted by PSE&G, and approved by the inspection authorities having jurisdiction. A separate meter may be required. A de-rated line connected neutral may be used for fire pump service only. All fire pumps will be metered at locked rotor current.
5. For conduit fittings on the line side of the meter, removable plates shall have provisions for sealing or be made non-removable by means of breakneck screws or by peening over existing screw heads or other PSE&G approved methods. There is no objection to these fittings on the load side of meters, whether indoors or outdoors.
6. PSE&G will seal or lock meters and all enclosures containing meters, associated metering equipment, service entrance interrupting devices and wiring ahead of the meter. No one except a duly authorized employee of PSE&G is permitted to break or remove a PSE&G seal or lock, unless previously arranged with PSE&G. The customer will provide spare fuses for installation by PSE&G.
7. PSE&G will specify an outdoor meter location for residential service where practical. Meters for industrial and commercial customers may be located inside or outside. The customer shall provide a protective enclosure where required. PSE&G will specify the meter location and the type of equipment it will furnish.
8. Customers that are non-utility generators (**NUGs**) or net metering installations, will be required to install facilities in addition to those normally required by PSE&G. These additional facilities are typically required for safety, relay protection, metering and equipment indication purposes, and will be specified by PSE&G on a case-by-case basis.

2 Grounding

The following requirements apply to grounding:

1. The customer shall provide, install and connect, in accordance with the current edition of the *National Electrical Code* and the *National Electrical Safety Code*, all grounding of services and service equipment, and install any required grounding of equipment furnished by PSE&G. Proper grounding is essential to ensure safe working conditions and proper operations of electrical equipment and systems.
2. The path to ground from circuit, equipment or conductor enclosures shall be permanent and continuous and shall have ample current carrying capacity to conduct safely any normal or transient currents likely to be imposed on it. The ground path shall have a sufficiently low impedance to limit the potential voltage above ground, and to facilitate the operation of the over-current devices of the circuit during all seasons of the year.
3. Where a neutral service conductor is brought in to a customer's installation, this conductor shall be connected to the grounding facilities of the installation at the service entrance switch or cabinet in accordance with the current editions of the *National Electrical Code* and the *National Electrical Safety Code*. Neutrals for underground services in overhead zones shall be insulated and fully rated.
4. The customer's grounding conductor shall not be connected in, or pass through, the meter enclosure or metering transformer enclosure.
5. Where a metal fence enclosure is used around a high voltage installation, the fence shall be connected to the ground bus of the installation at as many points as may be necessary to provide adequate protection in accordance with the current editions of the *National Electrical Code* and the *National Electrical Safety Code*. All grounding electrodes at such an installation shall be interconnected.
6. All plans for service installations submitted to PSE&G for acceptance shall show the provisions for grounding.
7. All other utility bonding shall not be connected to PSE&G service equipment.

3 Secondary Service Entrance Installations for Overhead Connection from Overhead Mains

The following requirements apply to secondary service entrance installations for overhead connection from overhead mains:

1. Where the service run is to be overhead from the PSE&G overhead mains or transformer, the customer shall install the service entrance installation up to and including the service head. It is the customer's responsibility to provide suitable support for the attachment of a PSE&G approved service hook for the service and to install the service hook. This support and hook must be capable of withstanding the pull of the service drop conductors.
2. Where a support must be erected to provide sufficient height for the point of attachment of the service drop, it shall be attached to the building and have adequate strength to withstand the pull of the service drop and shall be subject to approval by PSE&G (Refer to [Chapter 10, Section 7](#)). At locations where there are no buildings or structures, service may be provided to an approved free standing pole or timber supplied, installed and maintained by the customer. This pole should be fully treated pine, cedar, or equivalent wood, set 6 ft deep and with a cross section at the ground line of approximately 64 sq. in. (9 in. in diameter). Where, in the opinion of PSE&G, a terminal pole is required to attach the service run,

PSE&G reserves the right to install such a pole at the customer's expense. This pole will remain the property of PSE&G. No metering equipment shall be attached to PSE&G poles.

3. The service head and service run shall be out of reach from porches, windows, doors and fire escapes and shall be clear of awnings, fire escapes, building projections and other obstructions as required by the *National Electrical Code*. If the size of the service entrance conductors is No. 1 AWG or smaller, the conductors shall extend 2 ft out of the service head; if larger than No. 1 AWG, they shall extend 3 ft out of the service head.
4. The following sections and applicable drawings are included in [Chapter 10](#) of this manual:
 - [Section 1](#) – Service Entrance Clearances
 - [Section 2](#) – Grouped Meter Mounting Equipment Specifications
 - [Section 4](#) – Unacceptable Service Location
 - [Section 5](#) – Indoor Enclosure Overhead Secondary Service
 - [Section 6](#) – Service Entrance Mast – Galvanized Rigid Steel Conduit
 - [Section 7](#) – Service Entrance Installations

4 Secondary Service Entrance Installations for Underground Connection from Overhead Mains

The following requirements apply to secondary service entrance installations for underground connection from overhead mains:

1. Where the service conductors are to be run underground from the PSE&G overhead mains or transformer, the customer shall make the installation as provided in [Chapter 3](#). PSE&G will not replace a customer-installed conduit and/or cable for increased load requirements, damage due to overload conditions, or problems caused by improper installation such as settlement or terrain changes.
2. Conduit shall not be less than 2 in. for single-phase 100 A services, or less than 2-1/2 in. for 100 A three-phase services, (for services less than 100 A, 1-1/4 in. conduit is acceptable). For 200 A single-phase services 2-1/2 in. conduit is required, and no less than 3 in. conduit shall be used for 200 A three-phase services. Conduit runs shall be installed in a water-tight manner or shall be arranged for suitable drainage, whichever may be specified by PSE&G. The service conduit shall be located as designated by PSE&G, and shall extend up the pole not less than 8 ft and not more than 11 ft above ground level. Conduit entering the building shall be effectively grounded in accordance with the *National Electrical Code*. Conduit runs shall be constructed using one material, for example all steel or all PVC. (See [Section 8](#) and [Section 10](#) in [Chapter 10](#).)
3. Conduit containing unmetered conductors under a building is not allowed. The local PSE&G Wire Inspector shall be consulted prior to the start of construction.
4. PVC (non-metallic) or galvanized rigid steel conduit may be used for service runs. When PVC conduit is used it shall be Schedule 80 Electrical Grade above ground and Schedule 40 (minimum) Electrical Grade below ground and NRTL listed. The conduit used for the service run shall be of one type. The use of aluminum conduit is not permitted. If PVC is used then expansion joints and support shall be required at the building riser; conduit needs to be secured to the building.

5. Where, in the opinion of PSE&G, a handhole is required in an underground conduit run, it shall be furnished according to PSE&G specifications. A copy of the necessary specifications may be obtained at any of PSE&G's local Electric Distribution Division offices.
6. Service entrance conductors shall be provided by the customer long enough to extend 3 ft or more beyond the secondary mains or the transformer on the pole. Not more than two sets of service conductors will be permitted on a pole, and not more than three phase conductors and the neutral conductor shall be installed in a single conduit. The neutral wire shall be insulated, shall be the same size as the conductors, and must conform to all requirements and regulations set forth in the current editions of the *National Electric Code* and the *National Electric Safety Code*. A separate grounding conductor is not permitted. The service conductors shall terminate in a bushing made temporarily rain tight, which later will be sealed by PSE&G. Underground service entrance conductors should be of ample size to carry the connected load with a voltage drop not exceeding one percent, and in no case shall they be sized less than No. 6 AWG. **The installation shall be 2 ft minimum and 4 ft maximum below the ground level, and the trench shall be left open until the installation has been inspected and approved by PSE&G.**
7. The following sections and applicable drawings are included in [Chapter 10](#) of this manual:
 - [Section 8](#) – Secondary Distribution Service Entrance – Underground Connections from Overhead Mains
 - [Section 10](#) – Specifications for Customer-Installed Underground Service Conduit – Overhead Zone

5 Secondary Service Entrance Installations for Connections from Underground Mains

The following requirements apply to secondary service entrance installations for connections from underground mains, and any charges will be determined in accordance with [Chapter 1, Section 16](#) of this manual and the Tariff:

1. For secondary service entrance installations from underground mains, PSE&G will furnish and install the service conduit run from its mains to the curblin. The customer shall install the conduit run from the meter or service entrance equipment to the curblin for PSE&G to connect to. The customer shall install and maintain the foundation opening to accommodate the service conduit. This conduit run shall terminate underground, in a fitting(s) that will permit connection with the service conduit run installed by PSE&G. Where the customer's conduit run is not readily accessible, PSE&G recommends that a spare conduit(s) be installed for future purposes. All conduit(s), pull boxes and trough installed by the customer for the service entrance must be of the type and size specified by PSE&G for the service conductors. If approved by PSE&G, the service entrance trenching work may be performed by the customer. In all cases the trench must be inspected by PSE&G and the local electrical subcode official prior to backfilling. In the event that the customer has landscaping or hardscaping that would be disturbed by PSE&G while installing the service run, the customer shall be responsible for the restoration costs, or bringing its connection point out to the curb line or clear of such landscaping or hardscaping, in accordance with [Chapter 3, Section 1](#), paragraph 9.
2. In BUD systems with outdoor meter locations, the customer shall install any conduit required for the service entrance installations. **If PVC is used then expansion joints shall be required at the building riser.**
3. PSE&G will install the service run conductors from its mains to the point of connection as provided in [Chapter 3](#).

6 Secondary Distribution Service Equipment

The following requirements apply to secondary distribution service equipment:

1. Where, in the customer's opinion, unusual conditions make it desirable to install service equipment of a type other than the PSE&G recommended standard, the local Electric Distribution Division – Inspection Department shall be consulted for their specific approval.
2. The service entrance equipment and meters shall be in a location which is unobstructed, readily accessible and convenient for the regular or emergency visits of PSE&G employees. Temporary uprights such as ladders and scaffolding are not acceptable for the purpose of having PSE&G employees perform work on service entrance equipment. Indoor meter locations shall in general be adjacent to the service entrance. Where such a location is not practical, permission must be obtained from the Electric Distribution Division – Inspection Department to locate the equipment at another suitable location designated by PSE&G. A permanent staircase to access metering equipment must be approved by PSE&G prior to installation.
3. Metered and unmetered wiring shall not be installed in a common raceway, trough or switchgear section.
4. All metering and instrument transformer equipment shall be in the same location (both outdoors, or in the same room indoors).
5. Billing meters shall normally be **Hot Sequence**; that is, billing meters shall be on the line side of customer interrupting devices, overcurrent devices, etc.

Consistent with *National Fire Protection Association 70E Arc Hazard Protection Standards*, PSE&G meters shall be **Cold Sequence**; that is, an interrupting device or devices will be permitted on the line side of the meters. All devices shall have provisions for PSE&G locks and seals to prevent unauthorized access to unmetered conductors. Cold Sequence metering shall be required if:

- Installation is to be served by 265/460 V or 277/480 V
- Grouped/Stack metering (see [Figure 10.2](#)) is required
- Solar photovoltaic metering is installed (Commercial only)
- Customer is served by a 1,500 or above kVA padmounted transformer (applies to 120/208 V installations as well)
- Bus collector room is used
- Customer is served by a Spot or Underground Network (Commercial only)

For all other situations not covered above, the local PSE&G Wire Inspector shall be consulted.

6. No branch circuits or devices other than those specifically approved by PSE&G are permitted on the supply side of the meter. Potential sensing is permitted on duplicate service equipment. Control power for duplicate service automatic transfer devices which require connection to incoming cables is permitted only with specific approval from PSE&G. Motor size, current draw and operation time/cycle must be indicated on switchgear prints for PSE&G review. This control power is limited to motor operation only, and a current limiting device, with size and location specified by PSE&G, must be installed and located under PSE&G seal. No other customer owned voltage transformers, shall be installed prior to PSE&G metering without written approval from PSE&G Inspection Supervisor.
7. The local Electric Distribution Division office will supply, upon request, the maximum design short circuit duty available at the point of connection. All service entrance equipment shall be specified to meet this requirement. Specific short circuit duty information for fuse and circuit breaker coordination studies will be supplied upon request of the customer.

8. The customer shall not install lightning arresters, surge suppressors or similar devices on the supply (incoming) side of the secondary service entrance interrupting device.
9. Construction details and meter mounting equipment arrangements for various types of services are shown in diagrams that may be obtained from the local Electric Distribution Division – Wiring Inspection Department.

7 Specifications for Primary Service

PSE&G will supply primary service from distribution circuits at nominal 2400/4160 V (4 kV) or nominal 7620/13,200 V (13 kV), three-phase, four-wire, wye. Determination of the supply voltage shall be made by the PSE&G.

The following requirements apply to specifications for primary service:

1. The local Electric Distribution Division office will provide “Customer Equipment Requirements for Primary Service” (also known as the *Plant Engineering Policies and Procedures (PEPP) Manual*) to customers upon request. These specifications are for the customer’s guidance only, and outline general PSE&G requirements for the customer’s equipment. Any detailed engineering is to be performed by the customer or such agent as the customer may designate. PSE&G may be consulted with in this process.
2. Billing meters shall normally be **Cold Sequence**, that is an interrupting device shall be located on the line side of the meters, unless otherwise requested by PSE&G.
3. The primary switchgear should be arranged so that the service enters through an incoming section that may include lightning arrestors, followed by a section containing an isolating switch and then a separate metering section, where PSE&G’s metering transformers will be mounted.
4. PSE&G’s review of major electrical equipment and approval of the final electrical plan must be secured by the customer prior to the fabrication of apparatus and purchase of equipment. Detailed plans shall be prepared by the customer. Three hard copies and one electronic pdf file shall be submitted to the local PSE&G Wiring Inspection Supervisor for review.

8 Requirements for Switchgear Review

The following requirements apply to switchgear review:

1. The local Electric Distribution Division office will provide a specification for each customer switchgear installation. This specification is for the guidance of the customer, and outlines general PSE&G requirements for customer equipment. Any detailed engineering is to be performed by the customer or such agent as the customer may designate. PSE&G may be consulted with in this process. **The customer is required to obtain an E1 Notification with approval from PSE&G engineering prior to switchgear review.**
2. PSE&G’s review of major electrical equipment and of the final electrical plan must be secured by the customer prior to the fabrication of apparatus and purchase of equipment. Detailed plans shall be prepared by the customer. Three hard copies and one electronic pdf file shall be submitted to the local PSE&G Wiring Inspection Supervisor for review.

3. Any service installation requiring one or more sets of current transformers must be formally submitted by the customer for acceptance by the local Electric Distribution Division. As a minimum, the following information is required for PSE&G review:
 - Site Plan indicating location and details of the switchgear room
 - Profiles showing the specific arrangement and dimensions of the interior and exterior of the switchgear
 - Electrical one-line diagram from PSE&G’s source through the customer’s switchgear; specifically, the drawings submitted should cover the following items:
 - A plot plan showing the location of the service entrance equipment.
 - A plan and elevation detail of the service entrance equipment including metering facilities and branch or sub-main interrupting devices.
 - A listing of the major service entrance equipment and materials unless these are detailed on the drawings.
 - A One-Line Diagram of the high-voltage (primary) electrical system. This drawing should include the metering current and potential transformers and DC schematic diagrams of the relaying scheme if applicable.
 - Conduit and manhole details.
 - Any generating sources.
 - Interrupting ratings shall be indicated on main fault clearing devices
 - Fault withstand rating shall be indicated on all bus work
 - Manufacturer model numbers and ratings shall be supplied
 - Connector specifications for actual connection to PSE&G service conductors
4. All Non-Utility Generators (**NUGs**) that connect to PSE&G facilities must submit their major electrical equipment and final electrical design plans to PSE&G for review before ordering major equipment. See [Section 9](#) (Non-Utility Generators) below and [Chapter 6, Section 7](#) (Non-Utility Generators and/or Parallel Operations with PSE&G) for further information.
5. The following sections and applicable drawings are included in the [Chapter 10](#) of this manual:
 - [Section 18](#) – Minimum Clearances and Bus Arrangement for Bar Type Current Transformers 200 to 800 A Secondary/Switchgear
 - [Section 19](#) – Mounting Dimensions for Current Transformers in Cubicle – Window Type >801 A to 4000 A Secondary/Switchgear

9 Non-Utility Generators (NUGs)

The local Electric Distribution Division office will provide requirements to be followed by all NUGs. Before major electrical equipment is ordered and detailed design is started, a preliminary plan including a single line diagram must be submitted by the applicant for PSE&G’s review and approval. Written acceptance must be obtained from PSE&G, stating that the customer’s design is suitable for connecting its facilities to the PSE&G system. NUG customers that export power into the PSE&G system may also need to contact the PJM Regional Transmission Organization (**PJM RTO**) regarding interconnection of its facilities, the details of which may be found at www.pjm.com. See [Chapter 6, Section 7](#) of this document for more information.

This Page Intentionally Blank

Chapter 5 – Meters and Auxiliary Equipment – Contents

1	General	5-1
2	Metering Transformers and Associated Equipment	5-3
3	Multiple Meter Installations for Residential Unit Buildings and Office Buildings	5-4
4	Check Metering	5-5

This Page Intentionally Blank

Chapter 5 – Meters and Auxiliary Equipment

1 General

The following are general requirements for metering:

1. PSE&G provides certain meter enclosures for standard installations within its service area. The use of meter enclosures not provided by PSE&G must be reviewed for conformance with PSE&G requirements prior to purchase. Contact your local PSE&G Wiring Inspection Department for details. Group or stacked meter enclosures are not provided, but must meet PSE&G specifications. Self-contained meter enclosures will not be issued for installations using stacked meter enclosures. Contact the local PSE&G Wiring Inspector for assistance. To control the issue of meter enclosures that are provided by PSE&G, PSE&G requires that the customer or contractor present proof that an application has been made to the local municipal inspection authority. This proof must be the original papers given to the customer by the permitting authority. PSE&G does not accept photocopies unless properly stamped by the municipality. This form will then be stamped by PSE&G and returned to the customer when the equipment is issued. If the service installation has already been completed, the customer is not entitled to a meter pan.
2. A meter installation, equipped where necessary with demand and recording devices, will be furnished and installed by PSE&G for each separately billed rate schedule under which a customer receives service. If more than one meter is installed because PSE&G considers multiple meters necessary for operating reasons, the kilowatt hour usage measured by these meters will be combined for billing purposes using an applicable rate schedule. If additional meters are furnished and installed at the customer's request, the usage measured by each meter will be billed separately using an applicable rate schedule.
3. The service and supply of electric energy by PSE&G for the use of owners, tenants or occupants of buildings or premises will normally be furnished directly to them as customers of PSE&G through individual meters.
4. Meters shall be located in a place where they are accessible for reading and servicing. In special situations, if meters are located indoors in a locked room, a lock box utilizing a PSE&G 620 lock will be provided to hold a customer-supplied key for this location.
5. As a general requirement, meters shall not be installed in alleyways, walkways or driveways where their location may interfere with the normal flow of traffic or be subject to mechanical damage. If PSE&G determines that where stacked metering or CT metering equipment is located might subject it to damage by vehicles, the customer shall provide adequate bumper protection. The bumpers (bollards) and their location shall be approved by PSE&G and shall consist of 4 in. diameter galvanized steel pipe filled with concrete, or equivalent, set in concrete. Bumpers shall have a minimum height of 4 ft above grade, a minimum depth of 3 ft below grade and set a minimum of 8 in. away from the edge of the meter pan on both sides, and 10 in. in front of the pan. The bumpers shall not block the meter pan in the event it should ever need to be removed. In traffic areas where the bumpers might not be clearly seen at night, they shall be painted with a fluorescent paint suitable for outdoor use. The maximum distance between bumpers shall be 5 ft. Bumpers, when specified, must be placed before the service is energized.
6. Meters and/or disconnects are not permitted on PSE&G or joint-owned poles.
7. A clear space of at least 36 in. from the property line – as defined by the municipality – shall be maintained in front of the face of all meter enclosures or CT cabinets. The clearance between electric and

gas meters shall be a minimum of 36 in. The clearance between electric meters and propane tanks shall be at least 10 ft.

8. On multiple meter installations, the meters shall be stacked and the designation of the portion of the building served by each meter shall be permanently marked on the customer's load switch, meter cover and panel. Any exception to stacked metering must be reviewed and approved by PSE&G. See [Section 3](#) of this chapter for more details.
9. Pole Top Metering is an acceptable installation for 4 kV and 13 kV primary customers, provided PSE&G determines that it does not create an unsafe condition, and only where there is an otherwise uncorrectible space problem with other forms of metering. In order for PSE&G to reach such a determination, the customer must first present the basis for the review, and only then will PSE&G perform a study to decide whether such an installation is warranted.
 - a. For those projects that involve conversion from secondary to primary metering, a minimum load of 500 kVA is required. In addition to the above requirements, all work, including removal of primary metering, for a project of this nature is billable on a time and material basis, and funds must be received from the customer before PSE&G starts the project. Billable work includes, but is not limited to: design, engineering or engineering analysis, labor and materials costs, including the costs of any studies requested by the customer, and/or its consultant, for PSE&G's evaluation of the project. Additionally, the customer should be aware that PSE&G will not sell any of its facilities to the customer.
 - b. Any approved pole top metering facility shall be in full compliance with PSE&G requirements, and all applicable code requirements, including the approval of any local, State or federal agencies that have appropriate code inspection jurisdiction.
10. No weatherhead, pole top, or padmount metering transformer installation shall be accepted.
11. Any metering enclosure and associated equipment may be enclosed by the customer subject to the approval of PSE&G.
12. No person except a duly authorized PSE&G employee or agent is permitted to alter, change, or remove a meter or its connections.
13. The customer shall be responsible for the protection of the metering installation.
14. Combination meter pan and main units are not acceptable.
15. The following sections and figures are included in [Chapter 10](#) of this manual:
 - [Section 11](#) – Single-Phase, Two-Wire 120 V for Two-Wire Socket Meter
 - [Section 12](#) – Single-Phase Three-Wire 120/208 or 120/240 V Three-Wire Socket Meter
 - [Section 13](#) – Three-Phase, Three-Wire, 240 V Service – Ungrounded System
 - [Section 14](#) – Three-Phase, Four-Wire Services
 - [Section 15](#) – Grounding and Bonding
 - [Figure 10.20](#): 120/208 or 120/240 V Service
 - [Figure 10.21](#): Trough with Multiple Enclosures, 120/208 or 120/240 V Service – Main Interrupting Device Before Meters
 - [Figure 10.22](#): Meter Location Remote from Service Entrance Load Interrupting Device but in Same Building
 - [Figure 10.23](#): Combination Power and Light (4 W Delta Service)

2 Metering Transformers and Associated Equipment

The following are general requirements for metering transformers, and any charges will be determined in accordance with [Chapter 1, Section 16](#) of this manual and the Tariff:

1. Where the service size exceeds 200 A, three-phase or 320 A single-phase (residential only), Current Transformers (**CTs**) will be used for revenue metering. Current transformers may be used for lesser loads at voltages exceeding a nominal 240 V. In addition, Potential Transformers (**PTs**) will be used, where in the opinion of PSE&G the supply voltage requires their use. Any such current and potential transformers shall be installed as provided in [Chapter 4 – Service Entrance Installations](#).
2. **Self contained 320 A single-phase meter installations are restricted to (120/240 V) residential use only.**
3. The necessary test switches and control cable or wire required for the metering transformers will be furnished by PSE&G and installed as provided in [Chapter 4 – Service Entrance Installations](#).
4. For installations requiring metering transformers, the customer shall furnish and install a metering transformer cabinet or cubicle, the design of which shall be accepted by PSE&G prior to installation. Metering transformers will be furnished by PSE&G for installation by the customer. Specific locations for installation, and dimensions, of the metering transformers shall be provided by PSE&G. The meter(s) shall be located within 80 conductor feet of the metering transformers; and if the distance exceeds 80 ft, PSE&G must approve the design.
5. The secondary wiring of metering transformers normally will be furnished and installed by PSE&G. However, in certain cases, PSE&G may furnish the wire but require that it be installed by the customer.
6. All secondary wiring connections to meters, associated metering equipment, and metering transformers will be made by PSE&G.
7. All conduit installed by the customer for PSE&G's use as raceway for control wire or control cable for metering, when installed in conjunction with switchgear, shall be 2 in. threaded galvanized steel pipe from the CT's all the way back to the meter pan. The use of EMT or PVC conduit is not acceptable.
8. A suitable meter mounting space shall be provided by the customer. The customer shall provide supporting structures, boards or panels, as specified by PSE&G. All meter mounting equipment must be installed plumb and must be securely mounted upon a substantial support which is free from shock or vibration. Meter mounting boards or panels shall not be used for any other purpose. Meter mounting boards of 3/4 in. plywood construction shall have a minimum of 1 in. air space from the wall and shall be painted before the equipment is mounted. For permanent outdoor installations, plywood shall not be used for mounting equipment; consult with local PSE&G Wiring Inspector prior to installation. Meter pans shall not be directly attached to switchgear.
9. Meter mounting height shall be such that the top of the meter mounting equipment shall be as close as practicable to 5 ft from the floor or finished grade, but no lower than 3 ft from the bottom of the meter pan to the floor or finished grade, nor higher than 6-1/2 ft to the top of the meter pan. Where meters must be located next to walkways, and there is less than 24 in. clearance from the edge of the walkway to the back of the meter mounting equipment, the height shall be 6-1/2 ft from grade to the top of the meter mounting equipment. A clear space of at least 3 ft from the property line – as defined by the municipality – shall be maintained in front of the face of all meter enclosures or CT cabinets and not less than 3 ft of clearance from gas metering.

10. PSE&G will not permit the connection of customer's ammeters, voltmeters, pilot lamps or any other energy-using devices to the metering transformers used in conjunction with its billing meters, or before any other PSE&G metering.
11. Data pulses for monitoring energy, also known as Energy Evaluation Services, are available as an optional service for customers. The customer should contact the Service Consultant at the Construction Inquiry Center for further information concerning availability and charges.
12. The following sections and figures are included in [Chapter 10](#) of this manual:
 - [Section 15](#) – Grounding and Bonding
 - [Figure 10.24](#): Grounding and Bonding CT Enclosure – Hot Sequence, Bar Type CT
 - [Figure 10.25](#) – : Grounding and Bonding CT Enclosure – Cold Sequence Bar Type CT
 - [Section 16](#) – Approved Type Current Transformer Cabinet
 - [Figure 10.26](#): Maximum Capacity Parallel 500 kcmil Conductors
 - [Figure 10.27](#): Window Type >801 A Secondary
 - [Section 17](#)– Secondary Service Equipment with Bar Type Current Transformers (CTs)
 - [Figure 10.28](#): Maximum Capacity Parallel 500 kcmil Conductors – Three-Wire Services Single-Phase or Three-Phase
 - [Figure 10.29](#): Maximum Capacity Parallel 500 kcmil Conductors – Three-Phase Four- Wire Service
 - [Section 18](#)– Minimum Clearances and Bus Arrangement for Bar Type Current Transformers 200 to 800 A Secondary/Switchgear
 - [Section 19](#)– Mounting Dimensions for Current Transformers in Cubicle – Window Type >801 A to 4000 A Secondary/Switchgear
 - [Section 20](#)– Current Transformer Mounting Bracket Specifications and Dimensions

3 Multiple Meter Installations for Residential Unit Buildings and Office Buildings

For meter installations to residential unit buildings or office buildings where individual customers or tenants are separately metered at a secondary voltage, the following provisions are applicable:

1. PSE&G shall approve the location of all metering locations and metering arrangements.
2. The building owner/developer shall provide a minimum of three sets of prints to PSE&G that depict the meter room or closet locations in the building.
3. The building owner/developer shall provide meter rooms or closets in areas that are readily accessible to PSE&G employees at all times.
4. Usually, the meter rooms or meter closets would start on the second floor and there would be meter locations one floor below, on the meter room's floor, and one floor above. Typically, meter rooms or closets would be located on floors 2, 5, 8, 11, etc., or as specified by PSE&G. Other layouts are possible and require prior PSE&G approval.
5. All unmetered equipment shall have provisions for PSE&G seals or padlocks as required by PSE&G.
6. Meters shall be self-contained and all equipment must have provisions for sealing and securing meters and other related equipment, including bus duct, and cable raceway access points.

7. Meter rooms or closets shall be of sufficient size to allow for unhindered access for meter reading and servicing of equipment.
8. Stack metering may be used for residential and commercial applications; for additional installations consult with your local PSE&G Wiring Inspection Supervisor. Refer to the technical specifications for stack metering (Figure 10.2) which are available upon request from PSE&G.
9. The building owner/developer shall designate the corresponding apartment or office number on each individual meter pan.
10. All other sections of PSE&G's applicable standards shall apply to multiple meter installations for residential unit buildings and office buildings.
11. All unmetered, internal risers shall be in threaded rigid pipe, EMT or BUS duct, all other means must be preapproved by local PSE&G Wiring Inspection, prior to installation.

4 Check Metering

Check metering may be permitted under conditions defined in Section 9.2 of the *Tariff for Electric Service*. **Submetering is prohibited.**

1. Check Metering

Where a customer monitors or evaluates its own consumption of electrical energy, or any portion thereof, in an effort to promote and stimulate conservation, or for accountability by means of individual meters, computer programs or otherwise. When such metering is installed, operated and maintained at the customer's expense, such practice will be defined as check metering.

2. Submetering

Where customer-owners, landlords, tenants or occupants of buildings or premises resell energy by registration on such customer's owned metering, and the charges for such resold energy are in excess of the equivalent charge on the customer's own meter, such practice shall be defined as submetering and is in violation of the Tariff, and is not permitted.

This Page Intentionally Blank

Chapter 6 – Customer’s Installations – Contents

1	General	6-1
2	Motors – Starting Current	6-1
3	Motor Installations	6-3
4	Welders, Furnaces and Intermittent or Fluctuating Loads	6-4
5	Ranges, Ovens and Heaters	6-5
6	Gaseous Tube Lighting or Sign Equipment	6-5
7	Non-Utility Generators (NUGs) and/or Parallel Operations with PSE&G	6-5
8	Fire Alarms, Fire Pumps and Exit Lights	6-6
9	Voltage Sensitive Equipment	6-7
10	Load Management Services	6-8
11	Police and Fire Systems	6-8
12	Traffic Signal Systems and Roadway Lighting	6-8
13	Cellular Antenna Sites	6-8
14	Community Antenna Television (CATV) Power Supplies	6-9
15	Closed Circuit Camera Installation Requirements	6-9
16	Attachment of Holiday Decorations, Banners and Signs to Poles	6-13
16.1	Guidelines	6-13
16.2	Insurance Requirements	6-14

This Page Intentionally Blank

Chapter 6 – Customer’s Installations

1 General

The following are general requirements for customer installations:

1. Wiring installed on the customer’s premises must conform to all requirements and regulations set forth in the current editions of the *National Electrical Code* and the *National Electrical Safety Code*. Authorities having jurisdiction may have additional requirements that must be met in order to obtain a Certificate of Approval (Cut-in Card).
2. PSE&G must be notified before any additions or alterations are made to a customer’s electrical installation or equipment.
3. The customer’s wiring shall be so installed and connected that the service load will be balanced.
4. Motors, welders and other utilization apparatus shall be supplied, installed, connected, operated and maintained so that PSE&G’s service to other local customers is not affected.
5. If the use of certain equipment by the customer would cause objectionable voltage fluctuations or flicker, or would require electrical capacity out of proportion to the energy used for occasional, intermittent, momentary or short durations, and with a low load factor, the written approval of PSE&G shall be obtained before connecting such equipment. The customer or his agent shall provide information on the operating characteristics of this equipment to the Service Consultant at the Construction Inquiry Center prior to its installation.
6. The average power factor under operating conditions of customer’s load at the point where the electric service is metered shall not be less than 85%. Public Service may inspect customer’s installed equipment and may place instruments for test purposes at its own expense on the premises of the customer.
7. Where neon, fluorescent, or other types of lighting or sign equipment having similar low power factor characteristics are installed or moved to a new location, the customer shall furnish, install, and maintain at its own expense corrective apparatus which will increase the power factor of the individual units or the entire lighting installation to not less than 90%.

2 Motors – Starting Current

The following are general requirements for motors:

1. The inrush of current caused by a motor when it starts is usually much greater than the normal load current of the motor. The exact relation differs with the different sizes, speeds and types of motors. While this starting current exists for only a short time, it may cause objectionable dips in voltage, sometimes causing flickering lights to the customer or other customers served from the same system. PSE&G will determine what constitutes objectionable voltage dips. The customer shall be responsible for any corrective measures deemed necessary by PSE&G.
2. In predominantly residential areas and small commercial installations, the maximum motor starting currents and minimum demands listed in [Table 6-1](#) and [Table 6-2](#) shall apply. These ratings are based on not more than four starts per hour with long periods of continuous operation under maximum load conditions, except that domestic laundry equipment duty cycles are also acceptable. PSE&G shall be consulted where these conditions cannot be met, or where equipment ratings and/or starting characteristics exceed the values in [Table 6-1](#) and [Table 6-2](#).

Table 6-1: Equipment and Motors Rated in Horsepower (hp)

Voltage Class	Motor Size	Total Locked Rotor Current Not to Exceed	Minimum Demand
120 V, Single-Phase	All Motors	50 A	—
208 or 240 V, Single-Phase	2 hp or less	60 A	—
	3 hp	80 A	—
	4 hp	100 A	—
	5 hp	120 A	—
	6 hp	140 A	—
	6.5 hp and greater	150 A	—
208 or 240 V, Three-Phase	2 hp or less	50 A	—
	3 hp	64 A	10 KW
	4 hp	78 A	10 KW
	5 hp	92 A	10 KW
	6 hp	106 A	10 KW
	7 hp	120 A	10 KW
	10 hp	162 A	20 KW
	15 hp	232 A	20 KW
	20 hp	292 A	30 KW
460 or 480 V, Three-Phase	All Motors	Use 1/2 value of 208/240 V, Three-Phase Motors	
Note: Three-phase supply is not normally available for residential service.			

Table 6-2: Air Conditioning or Heat Pump Equipment Rated in BTU

Voltage Class	Capacity	Total Locked Rotor Current Not to Exceed	Minimum Demand
120 V, Single-Phase	All	50 A	—
208 or 240 V, Single-Phase	20,000 BTUH or less	60 A	—
	25,000 BTUH	75 A	—
	30,000 BTUH	90 A	—
	35,000 BTUH	105 A	—
	40,000 BTUH	120 A	—
	50,000 BTUH	150 A	—
208 or 240 V, Three-Phase	20,000 BTUH or less	50 A	—
	30,000 BTUH	75 A	10 KW
	40,000 BTUH	100 A	10 KW
	50,000 BTUH	125 A	10 KW
	60,000 BTUH	135 A	10 KW
	75,000 BTUH	150 A	10 KW
	100,000 BTUH	175 A	20 KW
	150,000 BTUH	225 A	20 KW
	200,000 BTUH	275 A	30 KW
	225,000 BTUH	300 A	30 KW
460 or 480 V, Three-Phase	All	Use 1/2 value of 208/240 V, Three-Phase	
Note: Three-phase supply is not normally available for residential service.			

3. Total locked rotor current is the steady state current taken from the supply line with motor rotor or rotors locked, with all other power consuming components including a current reducing starter, if used, connected in the starting position, and with rated voltage and frequency applied.
4. Where the equipment contains more than one motor and some motors are arranged for sequential starting, the above tables apply to that combination of power consuming components simultaneously started that produces a higher starting current than any other combination. The interval between successive steps shall not be less than one-half second.
5. All meter fire pumps shall be metered at locked motor current, and not running amps.
6. Where the design of the equipment is such that unequal currents appear in the supply wires, the tables apply to the supply wire carrying the largest current.
7. For two-phase motors the locked rotor currents specified in the tables shall be multiplied by the appropriate phase correction factor, e.g., 0.866.
8. In commercial or industrial areas, the starting current limitation per step, when the starting frequency does not exceed one start per hour, for single-phase and polyphase motors up to 240 V rating, shall be 100 A plus 1-1/2 A per horsepower of connected load. The connected load in horsepower may consist of motors, lights, etc. including the motor under consideration. Higher starting currents may be acceptable in certain cases for motors that start infrequently, and upon receipt of a customer application accompanied by complete data on the proposed operating cycle and motor characteristics, PSE&G will determine the permissible starting currents. This rule applies to installations having 300 hp or less connected load. For larger installations PSE&G will determine what starting currents are permissible.
9. A motor or motors may be started “across-the-line” if the total locked-rotor current does not exceed the limitations given above. Current limiting starters may be used for motors requiring higher starting currents provided the current drawn in both the starting and the running position, as measured on the line side of the starter, does not exceed the limitations given above. When a starter is used, an appropriate time interval will of necessity be required for each step.
10. In group installations of two or more motors supplied from the same service, the starting current limit per step for the largest motor shall be the limit for any other motors in the group. Motors started simultaneously shall be considered as one motor equal to the combined starting current of the group.
11. Before purchasing motors, the customer should always consult PSE&G to determine the type of service to be supplied.
12. It is desirable that all motors over one horsepower be three-phase if three-phase service is to be supplied. Where practicable, dual voltage single-phase motors should be connected for 220 or 230 V operation where 120/240 V secondary service is to be supplied. Single-phase motors rated for 115/230 V operation should be connected for 115 V operation where 120/208 V service is to be supplied.
13. PSE&G reserves the right, in case of doubt about correct starting current values, to accept motors for connection to its service only after a test has been made to determine the starting current required.

3 Motor Installations

The following are general requirements for motor installations:

1. Motor installations must conform to the requirements of the current edition of the *National Electrical Code*, the *National Electrical Safety Code* and PSE&G.
2. Where overload releases are required they shall have an adjustable current setting and either a fixed or an adjustable time setting. The time setting should provide adequate thermal protection for the motor windings, and adjustable elements should be capable of providing a maximum delay consistent therewith.

3. It is recommended that automatically operated small motors such as those used on refrigerators, oil burners and air conditioners, be individually equipped with time-delay thermal element protection.
4. Three-phase service is susceptible to a phenomenon known as single-phasing, due to the interruption of one or two phases of the three-phase supply. This may be caused by a number of factors in the utility system or the customer's wiring, including single-phase to ground faults, wires down due to storms, vehicle pole hit accidents, or blown fuses. Three-phase customers may receive sustained low voltage on one or two phases until normal service can be restored by PSE&G. The customer's equipment shall be adequately protected for these conditions if three-phase service is supplied.
5. Undervoltage (low-voltage) protection may be necessary on motors, or groups of motors, to meet the safety requirements of the *National Electrical Code* or the *National Electrical Safety Code*. The use of instantaneous low-voltage devices is generally undesirable, and therefore time-delay undervoltage devices should be used. The time lag of time-delay undervoltage devices should be adjustable to at least two seconds and should be adjusted to meet the requirements of the specific installation. Undervoltage protection should not be used on service switches or breakers.
6. Low voltage releases and over-current protection are not required on intermittent duty motors such as elevator, crane, hoist, and drag line motors.
7. The direction of phase rotation of the alternating current supply is carefully maintained by PSE&G, but motors for elevators, cranes, hoists and apparatus requiring constant direction of rotation such as vertical pumps should be equipped with suitable protection against possible phase reversal.
8. PSE&G does not recommend the installation of adjustable speed drives (**ASDs**) on existing or new open-delta transformer services due to ASD performance issues. An alternative is for PSE&G to provide, where available or conditions permit, a closed delta supply allowing full capacity of the ASD/motor combination. There may be additional charges for provision of this type of service, depending on what PSE&G facilities are currently in the area. Where the provision of a closed delta service is impractical due to availability and/or cost, and an open-delta service already exists or will be provided, the ASD loads will either need to be de-rated or the ASD itself must be oversized for the intended application. Please review this issue with PSE&G prior to purchasing equipment.

4 Welders, Furnaces and Intermittent or Fluctuating Loads

PSE&G should be consulted before the customer purchases apparatus of this type. Because of the nature and method of operations, welders, furnaces and intermittent or fluctuating loads will not be accepted for service by PSE&G until a thorough investigation of each case has been made. It will be necessary to know the location of the load and its complete electrical characteristics, and typically special service arrangements and service equipment will be required. PSE&G may require the customer to eliminate objectionable voltage dips, or PSE&G may install additional transformers and line facilities to correct the condition, and establish an appropriate customer contribution or Facilities Charge for this equipment. See the forms contained in [Chapter 7](#) for more details on information required by PSE&G for this equipment.

So far as practicable, loads of this type shall be balanced across all three phases of the customer's electrical service.

5 Ranges, Ovens and Heaters

Domestic and commercial loads of this type shall be balanced on the service so far as practicable. The amount of current drawn when any unit or combination of units is switched on shall not exceed the amount of current that would be permitted for corresponding conditions of motor starting as described in [Section 2 Motors – Starting Current](#), above.

6 Gaseous Tube Lighting or Sign Equipment

The following requirements apply to gaseous tube lighting or sign equipment:

1. Where neon, fluorescent, or other types of lighting or sign equipment having similar low power factor characteristics are installed or moved to a new location, the customer shall furnish, install, and maintain at its own expense corrective apparatus which will increase the power factor of the individual units or the entire lighting installation to not less than 90%.
2. Where a customer proposes using athletic field lighting fixtures that will utilize a 1500 W metal-halide lamp design, service shall be provided from a three-phase supply. The customer's lighting ballasts shall be connected phase to phase in order to avoid potential incompatibilities between the lighting ballast and the lamp design, and the voltage characteristics of PSE&G's system.

7 Non-Utility Generators (NUGs) and/or Parallel Operations with PSE&G

The following requirements apply to non-utility generators and/or parallel operations with PSE&G:

1. Whenever customer-owned generating facilities ("Non Utility Generators" or "NUGs") are installed for self-generating purposes and may export excess power into PSE&G's system, and/or parallel operation of the customer's generating equipment with the PSE&G system is requested, the generator installation shall conform with the NUG Requirements chapter of PSE&G's *Plant Engineering Policies and Procedures Manual*, copies of which are available on request from the local Electric Distribution Division office.
2. For small NUGs that are not eligible for Net Metering, the interconnection requirements of N.J.A.C. 14:8-4, "Net Metering and Interconnection Standards for Class I Renewable Energy Systems" shall not apply. PSE&G representatives will review the NUG proposal, inspect the customer's installation and will advise on any changes and/or additions or modifications required for interconnection where necessary. The NUG equipment shall not be operated in parallel with the PSE&G system until the required changes and/or additions or modifications have been made, and the final written acceptance by PSE&G and any governmental authority having jurisdiction have been received. Additional information can be found at the PSE&G website www.pseg.com.
3. Customer-owned generation **shall not** be connected within a CT or PT cabinet or any cabinet containing PSE&G metering equipment.
4. If the NUG intends to sell its power into the wholesale power market, it shall be required to meet the interconnection requirements of the PJM Regional Transmission Organization ("PJM"), copies of which can be found at www.pjm.com. The NUG would deal directly with PJM for all interconnection studies, and make all payments for studies and any interconnection costs directly to PJM.
5. Whenever a customer's generating equipment will not be operated in parallel with the PSE&G system, but is to be kept available for standby or emergency use, the customer shall install the necessary equipment to prevent parallel operation. The local PSE&G division must approve the equipment design proposed for each individual case.

6. The customer should design any emergency power system in accordance with Chapter 7 of the *National Electrical Code*. The design should take into account the use of time-delay relays in both the startup and shutdown phases of the emergency generator's operation. Some time delay built into the generator startup control logic may be desirable in order to avoid unnecessary generator operation due to momentary problems on the PSE&G system. Likewise, upon restoration of service by PSE&G, shutdown of the generator should be delayed until the voltage has stabilized, and the generator has had a sufficiently long enough operating period to ensure good performance in the future. The customer should discuss time delay settings with PSE&G, and operating recommendations with the generator manufacturer.
7. When PSE&G's service has been interrupted for any reason, the PSE&G system may re-energize the service without prior notice to the customer. Where a NUG operates a generator in parallel with the service furnished by PSE&G, the NUG is responsible for providing a means of automatic disconnection from PSE&G's system when power is interrupted.
8. The customer should discuss with PSE&G the design of any parallel operating generators using closed transition automatic transfer switches prior to purchasing any equipment. If an automatic transfer switch is utilized for a parallel operating generator, and PSE&G approves its use in a "closed transition" mode, then the duration of the closed transition should be less than 5 seconds.
9. The electrical protection of the equipment in the NUG substation or other electrical facilities is the sole responsibility of the NUG. PSE&G's interconnection equipment is intended solely for the protection of the PSE&G system, and to provide for the safety of its workers and the general public.
10. See [Chapter 9 – Class 1 Renewable Energy Interconnections](#) for inverted-based generation.

8 Fire Alarms, Fire Pumps and Exit Lights

The following requirements apply to fire alarms, fire pumps and exit lights:

1. Where service is supplied for other uses, and where the *National Electrical Code* requires a main disconnecting means ahead of a multiple metered installation, the fire alarm, fire pump or exit light circuit may be connected ahead of the main disconnecting means. This circuit must have its own disconnecting means and over-current device, and will be separately metered. Where the fire alarm or exit light circuit can be connected to the existing service entrance conductors on the line side of the service disconnecting means, and can be metered by connecting the existing meter also ahead of the service disconnecting means in accordance with the *National Electrical Code*, the circuit will not require a separate meter. Any meters required, unless treated otherwise due to operating reasons of PSE&G, will be billed separately.
2. Where the load is so small that metering is impracticable, as in the case of some types of fire alarm circuits, the billing of such service may be on an estimated basis at the option of PSE&G. Costs for this type of service may be obtained from the Service Consultant at the Construction Inquiry Center. Such use will be billed separately, or combined with the use shown on the customer's other existing meter, in accordance with the practice for metered circuits as stated above. No energy consuming devices, other than signalling lamps, bells or horns with an individual rating not greater than 100 W or 1/8 hp, shall be connected to such form of unmetered circuit.
3. Where no service is to be used other than fire alarms, fire pumps or exit or emergency lights, the service entrance installations shall be provided as required in [Chapter 4 – Service Entrance Installations](#).

9 Voltage Sensitive Equipment

The following requirements apply to voltage sensitive equipment:

1. Computers, variable speed drives, solid state devices, process equipment and other power sensitive equipment are very susceptible to many types of power disturbances and variations. Although PSE&G makes every reasonable effort to avoid problems on the utility system, various situations outside its control may still result in unwanted power disturbances affecting customer's sensitive equipment and systems. Equipment manufacturers, utilities and other experts agree that proper protection and mitigation of harmful power disturbances is best accomplished as electrically close to the affected equipment as practicable. Customers with equipment or processes sensitive to power variations and disturbances are expected to provide their own isolation from voltage sags, impulses, harmonics and other transient phenomena originating either from within the customer's facility or on PSE&G's system.
2. Customers planning on installing new equipment or processes with critical power requirements, should contact PSE&G to discuss the compatibility of the proposed equipment with other existing customer installations and utility electrical facilities and systems in the area.
3. The manufacturer of customer utilization and process equipment should be consulted to determine the need for any specialized power conditioning devices. Various technical guides, recommendations and standards should also be consulted when contemplating facility or equipment upgrades. A few of the applicable references include the latest versions of the following:
 - ANSI *American National Standard for Electric Power Systems and Equipment – Voltage Ratings (60 Hz)*, ANSI C84.1
 - *National Electrical Code*
 - Federal Information Processing Standards (**FIPS**) 94: *Guideline on Electrical Power For ADP Installations*
 - IEEE *Guide for Identifying and Improving Voltage Quality in Power Systems*, IEEE Std. 1250
 - IEEE Recommended Practice for: *Grounding of Industrial and Commercial Power Systems*, IEEE Std. 142
 - IEEE Recommended Practice for: *Emergency and Standby Power Systems for Industrial and Commercial Applications*, IEEE Std. 446
 - IEEE Recommended Practices and Requirements for: *Harmonic Control in Electrical Power Systems*, IEEE Std. 519
 - IEEE Recommended Practice for: *Powering and Grounding Sensitive Electronic Equipment*, IEEE Std. 1100
 - IEEE Recommended Practice for: *Monitoring Electric Power Quality*, IEEE Std. 1159
 - IEEE Recommended Practice for: *the Analysis of Fluctuating Installations on Power Systems*, IEEE Std. 1453
 - IEEE Standard for: *Interconnecting Distributed Resources with Electric Power Systems*, IEEE Std. 1547
 - National Electrical Manufacturers Association Standard for: *Motors and Generators*, NEMA MG-1
4. The customer shall ensure that no excessive harmonics or transients are introduced on to the PSE&G system. This may require special power conditioning equipment or filters. The IEEE Std. 519 is used as a guide in determining appropriate design requirements.
5. PSE&G is available to consult with customers in determining the susceptibility of power equipment and systems to the effects of power variations and disturbances. PSE&G, upon request, may also assist customers in the evaluation of appropriate protection and mitigation technologies.

10 Load Management Services

PSE&G offers Energy Evaluation Services to industrial and commercial customers. These services include internet access to billing and usage data, Demand Pulses only, or both Time & Demand Pulses. With this data the customer can operate Load Management equipment, obtain load profiles, and can access computer billing data at certain monthly intervals. Contact the Large Customer Support group at **1-800-664-4761** for more information on obtaining these services.

Monthly charges for the Energy Evaluation Services reflect the continuous services and maintenance costs incurred by PSE&G in supplying these services. Charges listed in the Tariff cover the installation and maintenance of equipment that PSE&G supplies to provide the service requested by the customer.

11 Police and Fire Systems

Police and fire systems mounted on poles on public highways will be metered if practicable, but otherwise may at the option of PSE&G be billed at a flat rate. Costs for this latter type of service may be obtained from your Service Consultant at the Construction Inquiry Center.

12 Traffic Signal Systems and Roadway Lighting

The following requirements apply to traffic signal systems and roadway lighting:

1. Traffic signal systems and roadway lighting may be installed without metering at the option of the Department of Transportation (**DOT**) provided, however, that if the DOT intends to install other loads such as receptacles, lighting, cameras, etc., the service shall be metered. If such loads are not currently installed, but may be added in the future, a meter hub should be installed for future metering purposes. If the meter hub is to be installed within the pedestal, the hub shall be located 6 in. from the top of the cabinet. The PSE&G single point of contact for the DOT at the local Electric Distribution Division office should be contacted for information on this type of service.
2. For traffic signal systems or roadway lighting supplied at 277/480 V or single-phase 480 V, PSE&G requires that a disconnect switch be installed ahead of the meter, and mounted on the outside of the cabinet. This disconnect switch and meter shall be in a NEMA 3R enclosure, and shall be lockable with customer's lock. The cover of the disconnect switch shall have provisions to accept a PSE&G seal. Grounds for the customer's equipment shall not be carried through PSE&G's meter panel.
3. Before actual construction is begun at the site, but after the DOT preconstruction meeting, the customer and/or its contractor, shall contact the local Electric Distribution Division Wiring Inspection Department to arrange for a site meeting to verify service type and location.
4. PSE&G shall inspect any trenches as soon as possible, but the contractor must schedule the inspection with advanced notice.
5. DOT shall be designing their installation in accordance with PE-OSHA, which requires a 10 ft spacing between their equipment and the PSE&G secondary.
6. Contact the Construction Inquire 1-800-722-0256.

13 Cellular Antenna Sites

The following requirements apply to cellular antenna sites:

1. For service connections to cellular antennas approved for location on PSE&G transmission poles or towers, contact the Wiring Inspection group at the local Electric Distribution Division office for requirements for service type and meter arrangements.

2. For service connections to a new cellular antenna site that is not located on or at a PSE&G facility, and where there are no existing cellular antennas, the first customer to connect is responsible for building all facilities that will be expected for all the antenna needs at this site. PSE&G's standard design requires a four meter panel be installed for either a single-phase or three-phase service connection, with blanks installed for future meters. In special cases, where only one customer will ever be connected at a site, a single-phase service with one meter may be allowed after consultation with PSE&G.
3. In the event that there is an existing cellular antenna service on a site, and a subsequent customer wishes to attach to this structure where the existing service is not capable of supplying the new customer, that customer shall be responsible for rebuilding the service to accept its load at its sole cost. The new facilities will be built as described above, unless PSE&G's Wiring Inspector agrees to a different design.
4. Where the customer wishes to attach a new antenna to an existing building or other structure, and there is an existing service for that facility, if there is sufficient existing service equipment and space to add another meter, the antenna could be served from the existing customer's service with the prior approval of PSE&G's local Electric Distribution Division Wiring Inspection Department. PSE&G may require the customer to build a four meter stack if additional antennas may be added in the future.

14 Community Antenna Television (CATV) Power Supplies

The following requirements apply to community antenna television (CATV) power supplies:

1. For CATV 120 V power supply pedestals, the customer will provide the service wires from the CATV power supply pedestal to the PSE&G transformer. If such service is to be installed in a joint trench, the customer shall install the service wire, and provide 3 ft of service wire coiled next to the transformer and left visibly above the ground. In the event that the customer must dig a new trench to the transformer, the trench shall have a minimum of 24 in. of clean cover over the wire, and enough service wire should be left coiled at the end of the customer-provided trench so that there would be 3 ft available at the transformer when all the trenching was completed. PSE&G will complete the remaining section of trench, and terminate the wire at the transformer.
2. For power supplies served underground from padmount transformers, the service shall terminate at a disconnect switch to be mounted on the outside of the power supply pedestal. The service shall enter the disconnect switch via conduit attached to the outside of the pedestal, either Schedule 40 PVC or rigid galvanized steel. Such conduit will extend a maximum of 18 in. below grade, and have a bushing to protect the service conductors. See [Figure 10.49](#) for details.
3. For CATV power supplies mounted on a joint pole, see [Figure 10.50](#) for details of installation.

15 Closed Circuit Camera Installation Requirements

The following requirements apply to closed circuit camera installations:

1. Cameras and associated Closed Circuit TV (CCTV) attachments are **only** permitted on **round wood distribution poles** and **round aluminum street and area lighting poles**. CCTV equipment is **not** permitted on the following street and area lighting poles:
 - a. Decorative poles shorter than 25 ft
 - b. Square aluminum poles of any size
 - c. Wooden laminated poles of any size
 - d. Fiberglass poles of any size
2. CCTV cameras and auxiliary equipment shall be attached to street light poles as illustrated and specified in [Figure 6.1](#) and according to the instructions and requirements that follow the figure.

Figure 6.1: Closed Circuit Camera Attachments to Street Light Poles (Wood)

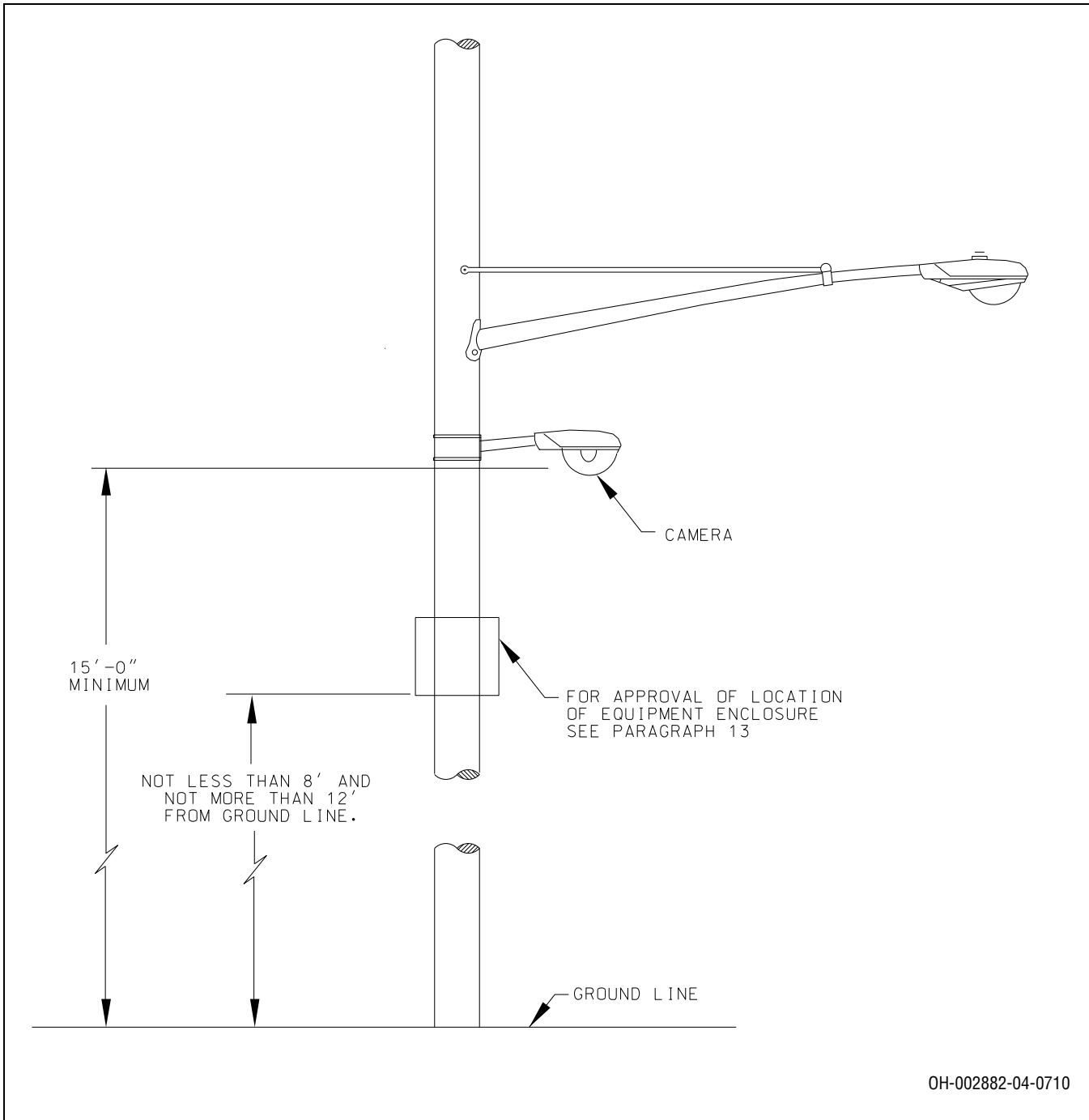

3. The following specifications **must** be provided to PSE&G for any CCTV equipment as a condition of approval for installation:
 - a. The Effective Projected Area (**EPA**) of each piece of equipment, pursuant to the American Association of State Highway and Transportation Officials (**AASHTO**) *Standard Specifications for Structural Supports for Highway Signs, Luminaires and Traffic Signals*, as adopted in 1994. The equipment must be designed to withstand wind speeds of 90 mph maximum and gusts of 117 mph maximum.

- b. The National Electrical Manufacturers Association (**NEMA**) four rated watertight and dust tight enclosures dimensions. The enclosure shall not exceed 10 in. wide by 12 in. high by 5 in. deep without written approval from PSE&G.
4. Only **wireless communication** CCTV systems are permitted on aluminum street light poles with underground power line feeds.
5. Any CCTV equipment requiring 120 V power shall be installed below the communication cables on wooden overhead-fed poles. The equipment shall be installed not less than 40 in. from secondary service wire, pursuant to NESC Rule 235-5, and not less than 8 ft, from ground line.
6. For street light poles, CCTV electrical connection to the utility's power source shall be through a polarized, three-prong plug connected to an electric utility's 120 V pole mounted outlet, provided by the electric utility. For wood poles, cameras can be connected to secondary.
7. One of four sides of the entire length of the pole must remain free for utility crew access.
8. Cameras shall not be mounted on the field (i.e. house) side of a street light pole.
9. Drilling into aluminum poles is strictly prohibited, including contractors. Cameras and control boxes must be secured to aluminum street light poles with approved metal straps or metal brackets bolted to the poles (see [Figure 6.2](#) through [Figure 6.4](#)).
 - a. A minimum of two stainless steel straps must be used to secure the camera to the pole.
 - b. Each strap shall be a minimum of 1/2 in. wide and 0.030 in. thick with a tensile strength of 1500 lb.
 - c. Each buckle shall be rated at double the tensile strength of the strap or approximately 3000 lb.
 - d. If a pole mount adapter plate is used, the plate shall have a minimum load bearing rating of 200 lb.
10. If the CCTV equipment requires a system ground and none exists, PSE&G shall provide and install a ground rod at the customer's expense.
11. Surveillance camera data transmission options are:
 - a. **Metal Poles:** Cameras mounted on PSE&G metal street light poles must transmit data via an acceptable wireless device attached to the street light boom.
 - b. **Wood Poles:** Cameras mounted on wood poles owned exclusively by PSE&G may transmit data via:
 - i. an acceptable wireless device attached to the pole, or
 - ii. a communications cable from a communications company (other than Verizon) that is licensed to attach to a PSE&G solely owned pole.
 - c. If the communications service is provided by Verizon on a pole that is jointly owned by Verizon and PSE&G, the customer must first contact Verizon with the service request. Verizon must subsequently process an application with PSE&G to purchase interest in the pole. The license for the data transmission device must be issued by Verizon.
12. Poles and CCTV locations and installations shall be individually inspected and approved by the Engineering Department to ensure against weight overload and to verify that applicable requirements have been met.
13. One camera per pole.
14. Any exception to these requirements shall be reviewed and, if acceptable, given written approval on a case-by-case basis by the Technical Support Group in the Asset Management Department, Newark General Office.
15. [Figure 6.2](#) illustrates the type of metal strap approved by PSE&G.

Figure 6.2: Metal Straps to Mount CCTV Camera Bracket Round Metal and Wooden Street Light Poles



16. [Figure 6.3](#) and [Figure 6.4](#) respectively illustrate PSE&G-approved CCTV camera attachments to wood poles and to round metal poles.

Figure 6.3: Camera Attachment to Wood Pole



Figure 6.4: Camera Attachment to Metal Pole



16 Attachment of Holiday Decorations, Banners and Signs to Poles

16.1 Guidelines

Note the following guidelines for attachment of holiday decorations, banners, and signs to poles:

- Written requests for temporary attachments are to be sent to the PSE&G Division Headquarters, identifying the street location and specific pole number(s) and the length of time attachments will be in place. Attachments are to be temporary in nature.
- Application, including specifications on proposed banners, is reviewed by PSE&G engineering to approve or deny based on PSE&G guidelines. A PSE&G Engineering Technician will contact the applicant with their results.
- Name of company or persons actually installing the banners must be supplied to PSE&G.
- Laminated wood poles are not to be used for pole to pole banners.
- No bolts or lag screws permitted for attaching to poles. A minimum of two stainless steel straps must be used to secure the banner to the pole.
- Pole to pole banners must weigh no more than 25 lb and must be vented to minimize wind resistance.
- A minimum clearance of 18 ft is required over roadway.
- Banner or sign attachments to be 40 in. below the lowest energized overhead low voltage conductors and no closer than 20 in. below a street light.
- Pole mounted banners must not exceed more than 2 ft beyond pole and measure no longer than 4 ft in length.
- No poles with electric conduits running up pole are to be used unless specific approval is given.
- If pole is jointly owned with Verizon Telephone Company, their approval must also be obtained.
- Proof of insurance must be provided, naming PSE&G as certificate holder to the PSE&G division reviewing the application prior to approval.
- All attachments must be within the pole manufacturer's guidelines for the Effective Projected Area (EPA) calculations.
- Attachments from pole to pole are prohibited.

16.2 Insurance Requirements

The following specific insurance requirements for pole attachments are derived from PSE&G's general provisions for insurance provided in the corporate procedures manual.

1. Before any attachments are made, licensee should provide proof of the following minimum insurance in forms and with insurance companies acceptable to PSE&G.
 - a. Workers' compensation insurance in accordance with statutory requirements and employers' liability insurance with a minimum limit of \$1,000,000 each occurrence.
 - b. Comprehensive General Liability Insurance (occurrence form) including premises, contractual liability, products liability, completed operations, independent contractors, broad form property damage, damage caused by structural injury, and damage to underground utilities with the following limits of liability:
 - Bodily Injury: \$1,000,000 each occurrence
 - Property Damage: \$1,000,000 each occurrence
 - c. Comprehensive Automobile Liability Insurance (only required if vehicles are to be used to install attachments) including coverage for all owned, non-owned and hired automobiles used by the licensee in the performance of the work with the following minimum limits of liability:
 - Bodily Injury: \$1,000,000 each occurrence
 - Property Damage: \$1,000,000 each occurrence
2. All liability coverages shall name PSE&G as an additional insured to support the contractual obligations assumed by the licensee in acceptance of this contract and provide that this coverage is primary and without right of contribution from insurance carried by PSE&G.
3. Prior to the commencement of this agreement, licensee will deliver to PSE&G certificates of Insurance evidencing this coverage is in effect and providing at least 30 days notice to PSE&G of any cancellation, termination, or material alteration of said insurance.
4. Licensee shall notify the company's representative and the claims department immediately by telephoning (973) 430-7000 and in writing within 24 hours after an occurrence thereof, of all accidents arising out of work done under this contract. Such notice shall not relieve either party of any of its obligations under this agreement, nor be construed to be other than a mere notification.
5. The insurance requirements as set forth above are to fully protect Public Service Electric and Gas Company from any and all claims by third parties, including employees of the licensee or its agents, sub-contractors, and invitees. Said insurance, however, is in no manner to relieve or release the licensee, its agents, sub-contractors and invitees from, or to limit their liability as to any and all obligations herein assumed.

PSE&G – Central Division Headquarters

472 Weston Canal Road
Somerset, NJ 08873
Paul Nicholas (732) 764-3190
Fax (732) 748-0573

PSE&G – Central Sub Division Headquarters

72 W. Jersey Street
Elizabeth, NJ 07202

Patricia D'Alia (908) 558-7520
 Fax (908) 353-7642

PSE&G – Metropolitan Division Headquarters

150 Circle Avenue
 Clifton, NJ 07011
 Joseph Appar (973) 365-5308
 Fax (973) 772-9442

PSE&G – Palisades Division Headquarters

325 County Road
 Secaucus, NJ 07094
 Onivaldo Rodrigues (201) 330-6558
 Fax (201) 866-2743

PSE&G – Southern Division Headquarters

300 New Albany Road
 Moorestown, NJ 08057
 John Felice (856) 778-6727
 Fax (856)-235-4276

PSE&G – Southern Division Subheadquarters – Trenton

4140 Quakerbridge Road
 Lawrenceville, NJ 08648
 Scott Brown (609) 799-6815
 Fax (609) 716-8599

Table 6-3: Listing of Counties and Towns – Central Division

Berkeley Heights	Garwood	Montgomery	Somerville
Bound Brook	Greenbrook	Mountainside	So. Bound Brook
Branchburg	Highland Park	New Bruns. Twp.	South Brunswick
Bridgewater	Hillsborough	North Brunswick	South Plainfield
Carteret	Hillside	North Plainfield	South River
Clark	Kenilworth	Perth Amboy	Springfield
Cranford	Linden	Piscataway	Union
Dunellen	Manville	Plainfield	Warren
East Brunswick	Metuchen	Rahway	Watchung
Edison	Middlesex	Raritan	Westfield
Elizabeth	Millstone	Roselle	Winfield
Fanwood	Milltown	Roselle Park	Woodbridge
Franklin	Monroe	Scotch Plains	

Table 6-4: Listing of Counties and Towns – Southern Division

Allentown	Edgewater Park	Monroe	Riverside
Audubon	Evesham	Maple Shade	Riverton
Audubon Park	Ewing	Medford Lakes	Runnemede
Barrington	Fieldsborough	Medford Twp.	South Brun. Twp.
Bellmawr	Franklin	Merchantville	Somerdale
Beverly	Florence	Moorestown	Southampton
Bordentown City	Gloucester City	Mount Ephraim	Springfield
Bordentown Twp.	Gloucester Twp.	Mount Holly	Travistock
Brooklawn	Haddon Twp.	Mount Laurel	Trenton
Burlington City	Haddonfield	Montgomery	Upper Freehold
Burlington Twp.	Haddon Heights	National Park	Voorhees
Camden	Hainesport	New Hanover	Washington
Cherry Hill	Hamilton	North Hanover	Westampton
Chesterfield	Hillsborough	Oaklyn	West Deptford
Cinnaminson	Hi-Nella Borough	Palmyra	Westville
Collingswood	Hopewell Borough	Pemberton	West Windsor
Cranbury	Hopewell Twp.	Pennington	Willingboro
Delanco	Lawnside	Pennsauken	Winslow
Delran	Lawrence	Plainsboro	Woodbury
Deptford	Lower Alloways Creek	Princeton	Woodbury Heights
East Amwell	Lumberton	Princeton Borough	Woodlynne
Eastampton	Magnolia	Princeton Twp.	
East Windsor	Mansfield	Rocky Hill	

Table 6-5: Listing of Counties and Towns – Metro Division

Belleville	Garfield	Newark	South Orange
Bloomfield	GlenRidge	North Caldwell	Totowa
Caldwell	Haledon	North Haledon	Union
Cedar Grove	Hawthorne	Nutley	Verona
Clifton	Irvington	Oakland	Wallington
East Orange	Lincoln Park	Orange	Wayne
Elmwood Park	Little Falls	Passaic	West Caldwell
Essex Fells	Livingston	Paterson	West Orange
Elizabeth	Maplewood	Prospect Park	
Fairfield	Millburn	Roseland	
Fair Lawn	Montclair	Saddlebrook	

Table 6-6: Listing of Counties and Towns – Palisades Division

Bayonne	Guttenberg	Moonachie	Saddle Brook
Bergenfield	Hackensack	New Milford	Saddle River
Bogota	Harrison	North Arlington	Secaucus
Carlstadt	Hasbrouck Heights	North Bergen	South Hackensack
Cliffside Park	Haworth	Old Tappan	Teaneck
Cresskill	Hillsdale	Oradell	Tenafly
Dumont	Hoboken	Palisades Park	Teterboro
East Newark	Hohokus	Paramus	Union City
East Rutherford	Jersey City	Park Ridge	Waldwick
Edgewater	Kearny	Ridgefield	Washington Twp.
Emerson	Leonia	Ridgefield Park	Weehawken
Englewood	Little Ferry	Ridgewood	West New York
Englewood Cliffs	Lodi	River Edge	Westwood
Fairview	Lyndhurst	River Vale	Woodcliff Lake
Fort Lee	Maywood	Rochelle Park	Wood-Ridge
Glen Rock	Midland Park	Rutherford	Wyckoff

This Page Intentionally Blank

Chapter 7 – Miscellaneous Forms and Applications – Contents

1	PSE&G’s Service Removal (Demolition) Process	7-11
1.1	Electric Service – Residential	7-11
1.2	Electric Service – Non-Residential	7-11
1.3	Gas Service	7-11
1.4	Completion Letters	7-11
1.5	Application Instructions	7-12

This Page Intentionally Blank

Chapter 7 – Miscellaneous Forms and Applications

The following forms and applications are available for the customer's guidance. The customer should always check with PSE&G to determine if a revision to these forms has been made:

1. Temporary Electric Service(s) Application ([ED-DC-IRE-Form001](#))
2. Permanent Electric Service(s) Load Information ([ED-DC-IRE-Form002](#))
3. Commercial/Industrial Project Contact Information Sheet ([ED-DC-IRE-Form003](#))
4. Residential Project Contact Information Sheet ([ED-DC-IRE-Form004](#))
5. Motor Data Sheet – 100 Horsepower and Above ([ED-DC-IRE-Form005](#))
6. Resistance Welder Data Sheet ([ED-DC-IRE-Form006](#))
7. Power Quality Data Sheet ([ED-DC-IRE-Form007](#))
8. Service Removal Request Application (Demolition) ([ED-DC-IRE-Form008](#))

For a full page print version of the form go to the [Forms](#) chapter. To open a fillable pdf form click the form number listed above.



Figure 7.1: Sample of Temporary Electric Service(s) Application (ED-DC-IRE-Form001)



Temporary Electric Service(s) Application
 ED-DC-IRE-Form001

Temporary Electric Service(s) Application

Name: _____

Location Address: _____

Town: _____

Phone No.: _____ Fax No.: _____

Email: _____

Electrician's Name: _____

Electrician's Phone No.: _____ Electrician's Fax No.: _____

Date Required: _____ Duration Temporary Power Needed: _____

Nearest Pole No.: _____ Nearest Pad No.: _____

Appliance Type	Single-Phase kW	Three-Phase kW	Number of Units	Total kW of Each Appliance by Type
Lighting				
Power Supply				
Air Conditioning				
Welder				
Motor(s) Pump(s) (Plus HP Rating)				
Elevators				
Miscellaneous				
Total kW Columns in this Row				

Service Voltage Characteristics

Service Amperage Size

Rev 0 – 10-Mar-17
Information and Requirements for Electric Service
Page 1 of 1

IRE-009212-01-1012

Figure 7.2: Sample of Permanent Electric Service(s) Load Information (ED-DC-IRE-Form002)



Permanent Electric Service(s) Load Information
 ED-DC-IRE-Form002

Permanent Electric Service(s) Load Information

Electric load information must be listed in kW for any and all new equipment to be installed by each appliance individually, then multiplied by the number of units and totaled in the far-right column. The electric service amperage size and voltage characteristics must be stipulated at the bottom of the page. When a miscellaneous load is listed, a description of its purpose must be supplied.

Appliance Type	Single-Phase kW	Three-Phase kW	Number of Units	Total kW of Each Appliance by Type
Interior Lighting				
Exterior Lighting				
Air Conditioning				
Heat Pumps				
Comfort Heating				
Water Heating				
Cooking				
Receptacles				
Motor(s) Pump(s) (Plus H P Rating)				
Fan(s)				
Refrigeration				
Elevators				
Computer				
Miscellaneous				
House Load				
Total kW Columns in this Row				

Service Voltage Characteristics

Service Amperage Size

Square Footage of Units

Total Square Footage of Premise

Air Conditioning Size in Tons

Rev 0 – 10-Mar-17
Information and Requirements for Electric Service
Page 1 of 1

IRE-009060-01-1012

Figure 7.3: Sample of Commercial/Industrial Project Contact Information Sheet (ED-DC-IRE-Form003)



Commercial/Industrial Project Contact Information Sheet
ED-DC-IRE-Form003

Commercial/Industrial Project Contact Information Sheet

Builder/Developer Company Name: _____

Builder/Developer Contact Name: _____

Mailing Address: _____

Phone No.: _____ Fax No.: _____

Cell No.: _____ Email: _____

Square Feet of Building(s): _____ Construction Start Date: _____

Building Location Description: _____

SIC Code: _____ Number of Units or Bays: _____

Number of Electric Meters: _____ Number of Common Area Meters: _____

Number of Gas Meters: _____ Number of Common Area Meters: _____

Electrical Contractor: _____

Address: _____

Phone No.: _____ Fax No.: _____

Cell No.: _____ Pager No.: _____

Email: _____

Mechanical Contractor (Plumber): _____

Address: _____

Phone No.: _____ Fax No.: _____

Cell No.: _____ Pager No.: _____

Email: _____

Rev 0 – 10-Mar-17

Information and Requirements for Electric Service

Page 1 of 1

IRE-009058-01-1012

Figure 7.4: Sample of Residential Project Contact Information Sheet (ED-DC-IRE-Form004)



Residential Project Contact Information Sheet
ED-DC-IRE-Form004

Residential Project Contact Information Sheet

Company Name: _____

Project Name: _____

Project Contact Person: _____

Mailing Address: _____

Phone No.: _____ Fax No.: _____

Cell No.: _____ Email: _____

Number of Buildings if Condo or Town Homes: _____

Number of Units or Apartments if Condo or Town Homes: _____

Number of Single Family Homes: _____

Construction Start Date: _____ Active Service Date: _____

Site Contact Name: _____

Address: _____

Phone No.: _____ Fax No.: _____

Cell No.: _____ Pager No.: _____

Email: _____

Electrical Contractor: _____

Address: _____

Phone No.: _____ Fax No.: _____

Cell No.: _____ Pager No.: _____

Email: _____

Mechanical Contractor (Plumber): _____

Address: _____

Phone No.: _____ Fax No.: _____

Cell No.: _____ Pager No.: _____

Email: _____

Rev 0 – 10-Mar-17 Information and Requirements for Electric Service Page 1 of 1

IRE-009210-01-1012

Figure 7.5: Sample of Motor Data Sheet – 100 Horsepower and Above (ED-DC-IRE-Form005)



Motor Data Sheet – 100 Horsepower and Above
ED-DC-IRE-Form005

Motor Data Sheet – 100 Horsepower and Above

Manufacturer’s Motor Data

Manufacturer’s Name: _____

Type (Squirrel Cage, Wound Rotor, Synchronous): _____

No. of Phases: _____ NEMA Code Letter: _____

Rated Voltage: _____ Rated Amperage: _____

Rated HP: _____ Power Factor: _____

Locked Rotor (Amps, kVA, or HP): _____

Power Factor at Starting: _____

Motor Operating Data

Desired Starting Frequency: _____ Number of Motor Starts Per Day: _____

Starting Devices:

Description of any external means of limiting the starting inrush current the customer may plan to employ (e.g. Auto Transformer).

Unusual Operating Characteristics:

Description of any unusual conditions, such as fluctuations from no load to full load while running, and the diversified loads and power factors for these conditions.

Rev 0 – 10-Mar-17Information and Requirements for Electric ServicePage 1 of 1

IRE-009059-01-1012

Figure 7.6: Sample of Resistance Welder Data Sheet (ED-DC-IRE-Form006)



Resistance Welder Data Sheet
ED-DC-IRE-Form006

Resistance Welder Data Sheet

Manufacturer's Welder Data

Rated kVA – 50% Duty Cycle: _____

Power Factor Percentage: _____

Welder Primary Voltage: _____ Phase Type: _____

Maximum Open Short Circuit Secondary Voltage: _____

Maximum Short Circuit Secondary Current: _____

Number of Welds Per Minute: _____

Welder Type: Spot Seam Projection Flash Other

Remarks:

DWMS Number: _____

Project/Service Consultant Name: _____

Date: _____

Rev 0 – 10-Mar-17Information and Requirements for Electric ServicePage 1 of 1

IRE-009211-01-1012

Figure 7.7: Sample of Power Quality Data Sheet (Page 1 of 2) (ED-DC-IRE-Form007)



Power Quality Data Sheet
ED-DC-IRE-Form007

Power Quality Data Sheet

Customer Name: _____ Date: _____

Service Address: _____

Project/Service Consultant Name: _____

Proposed Service DWMS No.: _____

Voltage: _____ Amperage: _____

Customer's Sensitive Equipment

PCs LAN Connected: Yes No

Equipment Type	Quantity	Total kVA
PCs		
Three-Phase Computers		
Adjustable Drive		
Programmable Logic Control		
Robotics		
Telecommunications Equipment		
Other		
Other		
Other		

Sensitive Processes (check all that apply)

Data Processing	Data Transmission	Telecommunications
Production	Testing – R&D	Other

Rev 0 – 10-Mar-17
Information and Requirements for Electric Service
Page 1 of 2

IRE-009208a-01-1012

Figure 7.8: Sample of Power Quality Data Sheet (Page 2 of 2) (ED-DC-IRE-Form007)



	Power Quality Data Sheet ED-DC-IRE-Form007																		
<p>Proposed Mitigation Equipment</p> <p>Surge Suppression</p> <p>Panel Mounted No.: _____</p> <p>Plug In and Other No.: _____</p>																			
<table border="1" style="width: 100%; border-collapse: collapse;"> <thead> <tr> <th style="width: 50%;">Equipment</th> <th style="width: 25%;">Quantity</th> <th style="width: 25%;">kVA</th> </tr> </thead> <tbody> <tr> <td>Single-Phase UPS/SPS</td> <td></td> <td></td> </tr> <tr> <td>Three-Phase UPS</td> <td></td> <td></td> </tr> <tr> <td>Line Conditioners</td> <td></td> <td></td> </tr> <tr> <td>Generators</td> <td></td> <td></td> </tr> <tr> <td>Other (Describe)</td> <td></td> <td></td> </tr> </tbody> </table>	Equipment	Quantity	kVA	Single-Phase UPS/SPS			Three-Phase UPS			Line Conditioners			Generators			Other (Describe)			
Equipment	Quantity	kVA																	
Single-Phase UPS/SPS																			
Three-Phase UPS																			
Line Conditioners																			
Generators																			
Other (Describe)																			
<p>Data Supplied by:</p> <p>Name: _____ Title: _____ Phone No.: _____</p> <p>E-mail Address: _____</p>																			
<p>Customer Contact(s):</p> <p>Name: _____ Title: _____ Phone No.: _____</p> <p>Name: _____ Title: _____ Phone No.: _____</p> <p>E-Mail Address: _____</p>																			
<p>Customer Electrical Consultant(s):</p> <p>Name: _____ Firm: _____ Phone No.: _____</p> <p>Name: _____ Firm: _____ Phone No.: _____</p> <p>Remarks:</p>																			
<hr/> Rev 0 – 10-Mar-17 Information and Requirements for Electric Service Page 2 of 2																			
IRE-009208b-01-1012																			

Figure 7.9: Sample of Service Removal Request Application (Demolition) (ED-DC-IRE-Form008)

	Service Removal Request Application ED-DC-IRE-Form008				
<input type="checkbox"/> <p>Public Service Electric & Gas Company P.O. Box 790, Cranford, NJ 07016-0790 Phone: 800-817-3366 Fax: 908-497-1878 E-mail: demolition@pseg.com</p>	<table border="1" style="width: 100%; border-collapse: collapse;"> <tr> <th style="text-align: center; padding: 2px;">For Office Use Only</th> </tr> <tr> <td style="padding: 2px;">Project No.:</td> </tr> <tr> <td style="padding: 2px;">E1 No.:</td> </tr> <tr> <td style="padding: 2px;">G1 No.:</td> </tr> </table>	For Office Use Only	Project No.:	E1 No.:	G1 No.:
For Office Use Only					
Project No.:					
E1 No.:					
G1 No.:					
<p>Service Removal Request Application Write clearly and review application instructions before completing this form.</p>					
Owner's Name: _____ Date: _____					
Owner's Authorized Agent: _____					
Premises Vacant? <input type="checkbox"/> Yes <input type="checkbox"/> No					
Service Address: _____ (of building to be Demolished)					
Mailing Address: _____					
Cross Street: _____					
Owner's Primary Residence? <input type="checkbox"/> Yes <input type="checkbox"/> No					
<p>Important: Application Will Not Be Accepted Until Applicant Has Taken Ownership and Property Is Vacant.</p>					
Project Contact: _____ Fax No.: _____					
Primary Phone No.: _____ Alternate Phone No.: _____					
E-mail Address: _____					
Meter Numbers: Gas _____ Electric _____					
Type and Number of Structures to be Demolished: _____ _____ _____					
PSE&G Lighting to be Removed: <input type="checkbox"/> Yes <input type="checkbox"/> No					
Other PSE&G Equipment (Poles, Transformers, Etc.)? _____					
Type of Electrical Service: <input type="checkbox"/> Overhead <input type="checkbox"/> Underground					
Type of Structure to be Built after Demolition: _____					
Approximate Date of Reconstruction: _____					
Signature: _____ Print Name: _____					
<p>By submitting this application, you are certifying that you are authorized to request removal of electric and gas services at the property specified above, and that the premises are vacant.</p>					
Rev 0 – 10-Mar-17	Information and Requirements for Electric Service				
	Page 1 of 1 IRE-009209-01-1012				

1 PSE&G’s Service Removal (Demolition) Process

Please review the following information to familiarize yourself with PSE&G’s Service Removal or “Demolition” Process. This process is designed to ensure the safety of both the public and our associates, and to abide by all applicable regulations. In certain cases, there may be charges for removal or abandonment of PSE&G facilities.

1.1 Electric Service – Residential

After your project has been entered into PSE&G’s DWMS system by the Demolition Group, a PSE&G Meter Technician will visit the premises to remove our electric meter. The primary contact indicated on the demolition application will be contacted directly if access to the meter is required. After the meter has been removed, PSE&G’s Construction Department will receive a work order(s) to remove wires, poles, and other equipment. Time frames for this work vary depending on the existing volume of customer work that has already been scheduled.

1.2 Electric Service – Non-Residential

Prior to the meter being removed, these projects are often reviewed by PSE&G’s Engineering Department, which creates DWMS work orders specific to the types of service and equipment at the premises. The work orders are forwarded to the Construction Department, and the appropriate crews and equipment are scheduled to perform the work. If there is area lighting to be removed, additional engineering and work crews are required.

1.3 Gas Service

PSE&G’s Demolition Group will contact you to make an appointment for the removal of any PSE&G gas meters that are inside the building(s). These appointments are between 8:00 AM - 12:00 PM or 12:00 PM - 4:00 PM, Monday through Friday.

After your project has been entered into PSE&G’s DWMS system, an electronic notification is sent to the District Office handling gas service in your municipality. That office will evaluate your request and determine whether or not a Road Opening Permit (**ROP**) is required by your municipality to enable PSE&G to perform the necessary work. Obtaining ROPs can take several weeks depending on the municipality, and permits for state and county roads could take longer. After the ROP has been received by PSE&G, markouts identifying other underground utilities must be requested. By state law, PSE&G cannot proceed with any physical work until at least the fourth day after the markout request.

1.4 Completion Letters

Once the Demolition Group has received verification from the Construction Department(s) that all necessary work has been completed, a letter will be sent, via fax, to the project contact and also by mail to the applicant indicated on the original demolition application.

1.5 Application Instructions

The application must be completed carefully and completely to ensure your request is properly handled.

1.5.1 Owner's Name

The project will be created in DWMS in the name of the owner of the property. Contractors or other authorized agents should be identified separately. People in the process of purchasing a property do not have the authority to submit an application until after the closing has occurred.

1.5.2 Vacancy

Services cannot be disconnected while the property is occupied. Meter removal may occur quickly after application, therefore, applications **will not** be accepted until the premises is vacant. If PSE&G finds the property to be occupied, the project will be cancelled and the applicant will have to re-submit their request.

1.5.3 Service Address

Refers to the address at which PSE&G provided service. This is often different from the mailing address of the property in question. The service address can be found on the PSE&G bill. This is crucial in making sure service is disconnected at the correct premises.

1.5.4 Mailing Address

The address to which the completion letter should be mailed. The letter will always be in the name of the property owner.

1.5.5 Cross Street

The nearest street intersecting the road the property sits on.

1.5.6 Primary Residence

Check "YES" if the building to be demolished is the applicant's primary residence.

1.5.7 Project Contact

The applicant's point of contact for property access and any other questions that may arise. This is the person who will receive the fax copy of the completion letter. Phone numbers should provide access to this contact during business hours.

1.5.8 Meter Numbers

These are located on the meters. Identify **all** gas and electric meters located on the property to be demolished. **Safe** access to all properties must be provided for meter removal.

1.5.9 Type and Number of Structures

Type refers to the structure's use, i.e. residential – single family or multi-family, warehouse, strip mall, etc. Specify which structures are to be demolished. For example, garage only, all units, residence but not pool house, buildings 1-4 and 7, etc. If the structures are not being taken all the way to the foundation, check with the municipality to make sure you really need a demolition permit.

1.5.10 Lighting

This generally refers to PSE&G pole mounted parking lot or area lighting at commercial or industrial properties. Please note – lights attached to buildings are not the responsibility of PSE&G. If there is area lighting on the property, does it need to be removed in order to demolish the building(s)? If the removal does not have to be done for demolition, it should be created as a separate project or as part of the new construction request with the Construction Inquiry Department. The Construction Inquiry Department can be reached at 1-800-782-0067.

1.5.11 Other Equipment

Are there any poles, transformers, or other equipment on the property that belong to PSE&G and need to be removed before demolition can occur?

1.5.12 Type of Electrical Service

Check “Overhead” if there is a wire from a utility pole to the buildings to be demolished. Otherwise, check “Underground”.

1.5.13 Type of Structure to be Built after Demolition

The use to which the new building will be put may affect the way services are removed for demolition. Please indicate whether a home will be built, a store, business, apartments, etc., and include the approximate timeframe for construction.

This Page Intentionally Blank

Chapter 8 – Electric Territory Served – Contents

Table 8-1: Municipalities Listed by County	8-1
Table 8-2: PSE&G Electric Distribution Division Offices	8-8

This Page Intentionally Blank

Chapter 8 – Electric Territory Served

Electric Headquarters Key	
Central	C
Central Sub-headquarter	CS
Metropolitan	M
Palisades	P
Southern – Lawrenceville	S
Southern – Moorestown	SS

Table 8-1: Municipalities Listed by County

County	Municipality	Electric Division
Bergen County	Allendale	P
	Bergenfield, Borough of	P
	Bogota, Borough of	P
	Carlstadt, Borough of	P
	Cliffside Park, Borough of	P
	Dumont, Borough of	P
	East Rutherford, Borough of	P
	Edgewater, Borough of	P
	Elmwood Park, Borough of	M
	Emerson, Borough of	P
	Englewood, City of	P
	Englewood Cliffs, Borough of	P
	Fair Lawn, Borough of	M
	Fairview, Borough of	P
	Fort Lee, Borough of	P
	Garfield, City of	M
	Glen Rock, Borough of	P
	Hackensack, City of	P
	Hasbrouck Heights, Borough of	P
	Haworth, Borough of	P
Hillsdale, Borough of	P	
Ho-Ho-Kus, Borough of	P	
Leonia, Borough of	P	

Table 8-1: Municipalities Listed by County (Cont'd)

County	Municipality	Electric Division
Bergen County (Continued)	Little Ferry, Borough of	P
	Lodi, Borough of	P
	Lyndhurst, Township of	P
	Maywood, Borough of	P
	Midland Park, Borough of	P
	Moonachie, Borough of	P
	New Milford, Borough of	P
	North Arlington, Borough of	P
	Oakland, Borough of	P
	Old Tappan, Borough of	P
	Oradell, Borough of	P
	Palisades Park, Borough of	P
	Paramus, Borough of	P
	Ridgefield, Borough of	P
	Ridgefield Park, Village of	P
	Ridgewood, Village of	P
	River Edge, Borough of	P
	River Vale, Borough of	P
	Rochelle Park, Township of	P
	Rutherford, Borough of	P
	Saddle Brook, Township of	P
	Saddle River, Borough of	P
	South Hackensack, Township of	P
	Teaneck, Township of	P
	Tenafly, Borough of	P
	Teterboro, Borough of	P
	Waldwick, Borough of	P
	Wallington, Borough of	M
	Washington, Township of	P
	Westwood, Borough of	P
Woodcliff Lake, Borough of	P	
Wood-Ridge, Borough of	P	
Wyckoff, Borough of	P	

Table 8-1: Municipalities Listed by County (Cont'd)

County	Municipality	Electric Division
Burlington County	Beverly, City of	SS
	Bordentown, City of	S
	Bordentown, Township of	S
	Burlington, City of	SS
	Burlington, Township of	SS
	Chesterfield, Township of	S
	Cinnaminson, Township of	SS
	Delanco, Township of	SS
	Delran, Township of	SS
	Eastampton, Township of	SS
	Edgewater Park, Township of	SS
	Evesham, Township of	SS
	Fieldsboro, Township of	S
	Florence, Township of	SS
	Hainesport, Township of	SS
	Lumberton, Township of	SS
	Mansfield, Township of	SS
	Maple Shade, Township of	SS
	Medford, Township of	SS
	Medford Lakes, Township of	SS
	Moorestown, Township of	SS
	Mount Holly, Township of	SS
	Mount Laurel, Township of	SS
	Palmyra, Township of	SS
	Pemberton, Township of	SS
	Riverside, Township of	SS
	Riverton, Township of	SS
Southampton, Township of	SS	
Springfield, Township of	SS	
Westampton, Township of	SS	
Willingboro, Township of	SS	
Camden County	Audubon, Borough of	SS
	Audubon Park, Borough of	SS
	Barrington, Borough of	SS

Table 8-1: Municipalities Listed by County (Cont'd)

County	Municipality	Electric Division
Camden County (Continued)	Bellmawr, Borough of	SS
	Brooklawn, Borough of	SS
	Camden, City of	SS
	Cherry Hill, Township of	SS
	Collingswood, Borough of	SS
	Gloucester, Township of	SS
	Haddon, Township of	SS
	Haddonfield, Borough of	SS
	Haddon Heights, Borough of	SS
	Hi-Nella, Borough of	SS
	Lawnside, Borough of	SS
	Magnolia, Borough of	SS
	Merchantville, Borough of	SS
	Mount Ephraim, Borough of	SS
	Oaklyn, Borough of	SS
	Pennsauken, Township of	SS
	Runnemede, Borough of	SS
	Somerdale, Borough of	SS
	Tavistock, Borough of	SS
	Voorhees, Township of	SS
Wood-Lynne, Borough of	SS	
Essex County	Belleville, Town of	M
	Bloomfield, Town of	M
	Caldwell, Borough of	M
	Cedar Grove, Township of	M
	East Orange, City of	M
	Essex Fells, Borough of	M
	Fairfield, Borough of	M
	Glen Ridge, Borough of	M
	Irvington, Town of	M
	Livingston, Township of	M
	Maplewood, Township of	M
	Montclair, Town of	M
	Newark, City of	M

Table 8-1: Municipalities Listed by County (Cont'd)

County	Municipality	Electric Division
Essex County (Continued)	North Caldwell, Borough	M
	Nutley, Township of	M
	Orange, Town of	M
	Roseland, Borough of	M
	South Orange Village, Township of	M
	Verona, Township of	M
	West Caldwell, Township of	M
	West Orange, Township of	M
Gloucester County	Deptford, Township of	SS
	National Park, Borough of	SS
	Washington, Township of	SS
	West Deptford, Township of	SS
	Westville, Borough of	SS
	Woodbury, City of	SS
	Woodbury Heights, Borough of	SS
Hudson County	Bayonne, City of	P
	East Newark, Borough of	P
	Guttenberg, Town of	P
	Harrison, Town of	P
	Hoboken, City of	P
	Jersey City, City of	P
	Kearny, Town of	P
	North Bergen, Township of	P
	Secaucus, Town of	P
	Union City, City of	P
	Weehawken, Township of	P
	West New York, Town of	P
Mercer County	Ewing, Township of	S
	Hamilton, Township of	S
	Hopewell, Borough of	S
	Hopewell, Township of	S
	Lawrence, Township of	S
	Pennington, Borough of	S
	Princeton, Borough of	S

Table 8-1: Municipalities Listed by County (Cont'd)

County	Municipality	Electric Division
Mercer County (Continued)	Princeton, Township of	S
	Trenton, City of	S
	Washington, Township of	S
	West Windsor, Township of	S
Middlesex County	Carteret, Borough of	CS
	Cranbury, Township of	S
	Dunellen, Borough of	C
	East Brunswick, Township	C
	Edison, Township of	C
	Highland Park, Borough of	C
	Metuchen, Borough of	C
	Middlesex, Borough of	C
	New Brunswick, City of	C
	North Brunswick, Township of	C
	Perth Amboy, City of	C
	Piscataway, Township of	C
	Plainsboro, Township of	S
	South Brunswick, Township of	C, S
	South Plainfield, Borough of	C
Woodbridge, Township of	C	
Monmouth County	Allentown, Borough of	S
	Upper Freehold, Township of	S
Morris County	Lincoln Park, Borough of	M
Passaic County	Clifton, City of	M
	Haledon, Borough of	M
	Hawthorne, Borough of	M
	Little Falls, Township of	M
	North Haledon, Borough of	M
	Passaic, City of	M
	Paterson, City of	M
	Prospect Park, Borough of	M
	Totowa, Borough of	M
	Wayne, Township of	M
West Paterson, Borough of	M	

Table 8-1: Municipalities Listed by County (Cont'd)

County	Municipality	Electric Division
Somerset County	Bound Brook, Borough of	C
	Branchburg, Township of	C
	Bridgewater, Township of	C
	Franklin, Township of	C, S
	Green Brook, Township of	C
	Hillsborough, Township of	C, S
	Manville, Borough of	C
	Millstone, Borough of	C
	Montgomery, Township	S
	North Plainfield, Borough of	C
	Raritan, Borough of	C
	Rocky Hill, Borough of	S
	Somerville, Borough of	C
	South Bound Brook, Borough of	C
	Warren, Township of	C
Watchung, Borough of	C	
Union County	Clark, Township of	CS
	Cranford, Township of	CS
	Elizabeth, City of	CS
	Elizabeth, Port of	M
	Fanwood, Borough of	CS
	Garwood, Borough of	CS
	Hillside, Township of	CS
	Kenilworth, Borough of	CS
	Linden, City of	CS
	Mountainside, Borough of	CS
	Plainfield, City of	C
	Rahway, City of	CS
	Roselle, Borough of	CS
	Roselle Park, Borough of	CS
	Scotch Plains, Township of	CS
	Union, Township of	CS
	Westfield, Town of	CS
Winfield, Township of	CS	

Table 8-1: Municipalities Listed by County (Cont'd)

County	Municipality	Electric Division
Northern Construction Inquiry 1-800-722-0256		
Southern Construction Inquiry 1-800-832-0076		

Table 8-2: PSE&G Electric Distribution Division Offices

CENTRAL	CENTRAL - Sub-Headquarters
472 Weston Canal Road Somerset, NJ 08873	900 West Grand Street Elizabeth, NJ 07202
METROPOLITAN	PALISADES
150 Circle Avenue Clifton, NJ 07011	325 County Avenue Secaucus, NJ 07094
SOUTHERN	SOUTHERN - Sub-Headquarters
4140 Quaker Bridge Road Lawrenceville, NJ 08648	300 New Albany Road Moorestown, NJ 08057

Chapter 9 – Class 1 Renewable Energy Interconnections – Contents

1	General	9-1
2	Definitions/Acronyms	9-1
3	Process	9-3
3.1	N.J.A.C. Level Review Process	9-3
3.2	Allowable Capacity	9-4
3.3	Application Documentation	9-4
3.4	Application Review	9-5
3.5	Applicant Commits to Proceed with Constructing the Project	9-5
3.6	Coordination and Scheduling	9-5
3.7	Inspection and Testing	9-5
3.8	Acceptance	9-6
4	Applicants/Facility Requirements	9-6
4.1	Transformer	9-7
4.2	Trench, Conduit and Conductors	9-7
4.3	Telecommunication	9-7
4.4	Switch-gear	9-7
4.5	Disconnect Switch	9-7
4.6	Inspection and Maintenance	9-8
4.7	Solar Loan Program	9-8
5	Renewable Generation in Network Areas (Level 3)	9-10
5.1	Network Basics	9-11
5.2	Types of Networks	9-11
5.3	Network Interconnection Issues	9-12
5.4	Potential for Export of Power	9-13
5.5	Codes Governing Connections to Networks	9-13
5.6	Minimum Import / Reverse Power Relays	9-15
6	Additional Resources	9-16

This Page Intentionally Blank

Chapter 9 – Class 1 Renewable Energy Interconnections

1 General

The purpose of this document is to communicate the process and requirements for interconnecting an inverter based generator to PSE&G's electric distribution system. It should be used as a reference tool to help understand the different aspects involved with the process. Most of the document will be geared toward Level 1 and Level 2 interconnections as defined in [Section 3.1](#). Always consult with a qualified PSE&G associate before starting a project. This chapter will cover the basic elements related to:

- Definitions
- Process
- Installations in Network Areas

2 Definitions/Acronyms

Affected System

An electric system other than the PSE&G System that may be affected by the proposed customer-generator facility interconnection.

Aggregate Net Metering

A customer-generator with multiple facilities of the same rate class utilizing one of those facilities as a host site which produces more electricity than consumed at that site.

Applicant

Within this document the applicant may be several different parties involved with the process of interconnecting. For simplicity sake, the applicant may be any person or designee taking ownership of and responsibility for the construction, operation, ownership and maintenance of the facility.

Customer-Generator Facility

A customer that generates electricity using Class 1 renewable resources as defined in *New Jersey Administration Code (N.J.A.C.)* 14:8-1.2 on the customer's side of the meter.

E1 Notification

Refers to a formal request for information concerning all the customer-generator's facility requirements which is created in PSE&G's distribution work management system.

EDC

Electric Distribution Company

ESOC

PSE&G's Electric System Operations Center

IEEE 1547

Approved series of interconnection standards developed by the Institute of Electrical and Electronics Engineers (**IEEE**).

Interconnection Application and Agreement

Contractual agreement between the customer-generator and PSE&G to interconnect distributive generation to PSE&G's distribution system.

Interconnection Point

The point(s) of physical connection of the customer-generator facility to the PSE&G System located at the point where the PSE&G System meets with and connects to the customer-generator facility. Typically, this occurs at the point where the incoming line is terminated by PSE&G, such as at a disconnect switch or switches on the high side of a customer's circuit breaker or other load break device. This interconnection point or points should be identified on the customer-generator's facility single line diagram. This is also the point where certain SCADA and telemetering measurements should be effectively determined.

Inverter

A device that converts Direct Current electricity (**DC**) into Alternating Current (**AC**).

Net Metering

A system of metering electricity in which PSE&G:

1. Credits a Customer-generator at the full retail rate for each kilowatt-hour produced by a Class 1 renewable energy, installed on the Customer-generator's side of the electric revenue meter, up to the total amount of electricity used by that Customer during an annualized period; and
2. Compensates the Customer-generator at the end of the annualized period for any remaining credits, at a rate equal to the electric supplier's or BGS provider's avoided cost of wholesale power.

Non-Utility Generator (NUG)

Non-Utility Generator

PEP

Purchase Electric Power – Agreement to generate electric power and sell directly back to the EDC.

PJM

The Pennsylvania, Jersey, Maryland (**PJM**) Regional Transmission Organization, which oversees the operation of the transmission system in the region in which PSE&G operates, also has oversight of generator interconnections where the generator is exporting power for use in the wholesale marketplace. Generally, the exporting generation facility must have an aggregate output of over 1 MW to be PJM jurisdictional, and it can be connected to either the distribution system or the transmission system.

PSE&G System

The electrical facilities owned, controlled and operated by PSE&G.

Renewable Energy

Class 1 Renewable:

- Biopower – Produces electricity through the use of organic materials
- Fuel Cells – Stored electrical generation
- Solar or Photovoltaic Facility – Produces electricity from solar radiation
- Wave or Tidal
- Wind Facility – Produces electricity from a wind-powered generator(s)

Class 2 Renewable:

- Energy produced at resource recovery or hydro power facility

3 Process

This section outlines a framework for processing interconnection applications and ensuring that applicants are aware of the PSE&G Standardized Interconnection Requirements (**SIR**). This section also provides applicants with an understanding of the process and information required to permit PSE&G to review and accept the applicants' equipment for interconnection in a reasonable and expeditious manner.

The time required to complete the process will reflect the complexity of the proposed project. Projects using previously submitted designs that have been satisfactorily accepted will move through the process more quickly, and several steps may be satisfied with an initial application depending on the detail, completeness of the application, and supporting documentation submitted by the applicant.

The application process and associated services are offered by PSE&G on a non-discriminatory basis. The applicant is responsible for those costs that PSE&G would not have incurred but for the applicants' interconnections.

See Figure 3.1 for general overview.

3.1 N.J.A.C. Level Review Process

The N.J.A.C., Sections 14:8-4 and 14:8-5, defines the rules regarding interconnection based on the generation at the customer's site. The latest version of the regulations is available from the following website:

<http://www.lexisnexis.com/njoal/>

The level of interconnection is defined by the power rating of the inverter based system which also sets out specific evaluation criteria as follows:

Table 9-1: Interconnection Levels

Interconnection Level	System Rating	N.J.A.C. Requirements
Level 1	10 kW or less	14:8-5.4
Level 2	> 10 kW up to 2MW	14:8-5.5
Level 3	> 2 MW	14:8-5.6

3.1.1 Level 1

Each EDC shall adopt a level 1 interconnection review procedure. The EDC shall use the level 1 review procedure only for an application to interconnect a customer-generator facility that meets all of the following criteria:

1. The facility is inverter-based;
2. The facility has a capacity of 10 kW or less; and
3. The facility has been certified in accordance with N.J.A.C. 14:8-5.4.

3.1.2 Level 2

Each EDC shall adopt a level 2 interconnection review procedure. The EDC shall use the level 2 interconnection review procedure for an application to interconnect a customer-generator facility that meets both of the following criteria:

1. The facility has a capacity of two megawatts or less; and
2. The facility has been certified in accordance with N.J.A.C. 14:8-5.5.

3.1.3 Level 3

Each EDC shall adopt a level 3 interconnection review procedure. The EDC shall use the level 3 review procedure for an application to interconnect a customer-generator facility that does not qualify for the level 1 or level 2 interconnection review procedures set forth at N.J.A.C. 14:8-5.4 and 5.5.

3.2 Allowable Capacity

The maximum allowable capacities are:

- 4 kV - Maximum Capacity - 650 KW
- 13 kV - Maximum Capacity - 5 MW
- >13 kV - Impact Study Required

3.3 Application Documentation

The documents and application fees required from a customer vary depending on the type of interconnection being proposed. The relevant documents are outlined below:

Table 9-2: Interconnection Documents

Interconnection Type	Interconnection Document
Net Metering Level 1	Level 1 Interconnection Application/Agreement (with Terms and Conditions)*
Net Metering Level 2-3	Level 2-3 Interconnection Application/Agreement (with Terms and Conditions)*
PEP Tariff - Levels 1-3	Level 2-3 Interconnection Application/Agreement (with Terms and Conditions)*
PJM Tariff	N/A (Requests processed through Electric Planning group)
<p>*Application/Agreement documents and fees can be located at PSEG’s Website, or the NJ Office of Clean Energy Website: http://www.pseg.com/business/small_large_business/rebate/njcleanenergy.jsp http://www.njcleanenergy.com/renewable-energy/programs/net-metering-and-interconnection</p>	

Additional documentation required, but not limited to include:

- Site plan including the location of proposed interconnection point
- Electrical one-line including both the utility feed and customers equipment
- Detailed switchgear specifications

3.4 Application Review

A PSE&G representative will process the application for an initial review and feasibility study. This requires a basic assessment of the ability of the PSE&G System to accommodate the customer-generator's interconnection, including preliminary information about what service voltage level would be utilized and costs. The results of this study will determine whether or not an impact study and or facilities study will be required.

The applicant will be provided with an assessment of the technical feasibility of the proposed interconnection and proposed costs that may be incurred.

If it is determined that there may or will be a significant impact to the utilities distribution system, the customer will be informed that further study will be necessary. The applicant will then be required to:

- Provide PSE&G with a cost-based advance payment for the PSE&G review of the proposed generator.
- Submit a detailed design package.
- Confirm with PSE&G a mutually agreeable schedule for the project based on the applicant's work plans and the other discussions.

Additional exchanges of information between PSE&G and the applicant may be required to complete the design package according to PSE&G's technical requirements for interconnection.

Applicant will be informed of the results of any further studies and issued an estimate for all necessary work to accommodate the customer-generator's interconnection.

3.5 Applicant Commits to Proceed with Constructing the Project

The applicant will:

- Execute a standardized interconnection agreement or commit in writing to the applicable tariff requirements; and
- Provide PSE&G with an advance payment for PSE&G's estimated costs associated with system modifications, metering, and on-site verification.
- Provide a preliminary schedule of construction for the facility.

3.6 Coordination and Scheduling

The applicant will be provided with the contact information for the applicable PSE&G representative. The applicant shall contact this individual to schedule a project kick-off meeting.

At this initial meeting the applicant should be prepared to discuss:

- Scheduling
- Details of related documentation and drawings submitted
- Coordination
- Inspection requirements
- Metering requirements

3.7 Inspection and Testing

The applicant shall contact PSE&G's Metering and Inspection Department prior to ordering material or commencing construction.

3.8 Acceptance

Within a reasonable time after interconnection, PSE&G will review the results of its on-site verification and issue to the applicant a formal letter of acceptance for interconnection or Permission To Operate (**PTO**) as well as a copy of the fully executed agreement.

Installation of the customer-generator facility must be in compliance with the local, state and federal codes and regulations, and shall meet the requirements of IEEE Standard 1547 (2003) “Standard for Interconnecting Distributed Resources with Electric Power Systems” and any subsequent subparts of IEEE 1547, such as IEEE 1547.1 (2005) for testing protocols. The installation shall be done in a workmanlike manor, and shall meet or exceed industry standards of good practice. Prior to connection, PSE&G must be provided by the local Sub-code Official with a “cut-in card” or other evidence of the satisfactory electrical inspection by the authorized inspection agency having jurisdiction.

Note



PSE&G will not be liable for damages or for injuries sustained by customers or by the equipment of customers or by reason of the condition or character of customer’s facilities or the equipment of others on customer’s premises. PSE&G will not be liable for the use, care, or handling of the electric service delivered to the customer after same passes beyond the point at which PSE&G’s service facilities connect to the customer’s facilities.

Upon initial parallel operation of a generating system a “Witness Test” or verification test shall be performed by PSE&G, or any time interface hardware or software is changed, a verification test must be performed in accordance with the applicable requirements of IEEE Std 1547.1 (2005) “Conformance Test Procedures for Equipment Interconnecting Distributed Resources with Electric Power Systems.” A New Jersey Licensed Professional Engineer or qualified individual working under the direction of a New Jersey Licensed Professional Engineer must perform verification testing in accordance with the manufacturer’s recommendations, and use licensed electricians with experience in testing protective equipment. PSE&G reserves the right to witness verification testing or require written certification that the testing was performed.

Verification testing shall be performed every four years. All verification tests prescribed by the manufacturer shall be performed. If wires must be removed to perform certain tests, each wire and each terminal must be clearly and permanently marked. The generator-owner shall maintain verification test reports for inspection by PSE&G.

Single-phase inverters rated 10 kW and below may be verified once per year as follows: once per year, the owner or his agent shall operate the load break Disconnect Switch and verify the power producing facility automatically shuts down and does not restart for five minutes after the switch is closed.

Any system that depends upon a battery for trip power shall be checked and logged once per month for proper voltage. Once every 4 years the battery must be either replaced or a discharge test performed.

4 Applicants/Facility Requirements

The following are requirements for all customer-generator facilities regardless of size or intent to sell to PSE&G or elsewhere.

To qualify for Net Metering, a customer-generator must generate Class 1 renewable energy as defined in N.J.A.C. 14:8-1.2. Further, to qualify for Net Metering, the capacity of the customer’s generating system cannot exceed the amount of electricity supplied by the electric power supplier or basic generation service

provider to the customer's residence or facility, as applicable, over an annualized period. Customer-generators that qualify for Net Metering shall be referred to as "Qualified Customer-Generators"

In addition to the requirements of N.J.A.C. 14:8-1 and 14:8-4, a Net Metering customer shall ascertain and comply with the requirements of PSE&G which are available on the NJ Clean Energy Program website, at www.njcep.com and the PSE&G website at www.pseg.com; and as applicable, to be found in this document. In addition, the Net Metering customer shall be responsible for meeting all applicable safety and power quality requirements as approved by: the *National Electrical Code*; the *National Electrical Safety Code*; accredited NRTL standards, such as Underwriters Laboratories UL 1741; and Institute of Electrical and Electronics Engineers standards, guides and practices, specifically IEEE Standard 929, and IEEE Standard 1547 and its subparts.

The information contained herein is general and not intended to cover all details and aspects of a particular project. PSE&G should be consulted in case of doubt on the current applicability of any item.

Any information contained in this document is subject to change without notification. It is the customer-generator's responsibility to verify current applicability of information through written inquiry to PSE&G.

It is PSE&G's policy to permit customer-generator facilities to operate their generating equipment in parallel with PSE&G's electric distribution system provided there are no expected adverse effects to the reliability or quality of service currently provided to other customers, or to the safety of PSE&G's workers or the general public.

4.1 Transformer

PSE&G will provide and install any transformers required on the primary side of the switch-gear at the applicant's expense. The applicant will supply and appropriate base for PSE&G to install the Pad and Transformer on. This base must conform to PSE&G specifications and will be inspected prior to installation of the Pad.

4.2 Trench, Conduit and Conductors

The applicant will be responsible for all trench, conduit and secondary conductors required. Primary conductors will be provided and installed by PSE&G at the applicant's expense. It is the applicant's responsibility to conform to all PSE&G specifications for trench and conduit installation as well as coordination of all inspections required for such work.

4.3 Telecommunication

The applicant is responsible for all telecommunication conduit and conductors. The applicant is also responsible for all coordination and communication with the telecommunication company.

4.4 Switch-gear

The applicant is responsible for the supply and installation of all required switch-gear elements. The switch-gear must strictly conform to PSE&G's specifications.

4.5 Disconnect Switch

A disconnect switch may be required depending on the size of the installation. It is recommended to be installed on both sides of PSE&G metering for most installations.

For Solar Loan Projects, Disconnects are required on both sides of the Utility Meter – Inverter, Production, or SREC.

4.6 Inspection and Maintenance

Periodic inspection and maintenance of the equipment and facilities is necessary to assure proper operation and function. PSE&G shall be granted access for its authorized representatives during any reasonable hours to install, check and maintain metering equipment and/or for operation of the interconnection disconnecting device.

Types of maintenance that the applicant would be responsible for at its facility consist of diagnostic testing and sampling, minor maintenance items and major maintenance items, for example:

- **Diagnostic Testing and Sampling**
Is performed either on in-service equipment or on equipment out of service but immediately available for service. Example would be thermovision heat detection scanning.
- **Minor Maintenance**
Would require the equipment to be out of service but available for return to service within a few hours or less. Examples might be lubrication of mechanisms, checking the proper operation of pressure switches; checking the operation and synchronism of disconnect switches, meggering, ductoring, timing checks, interrupting medium moisture tests as well as relay setting checks and operational function tests.
- **Major Maintenance**
Would include the complete or partial disassembly of a piece of equipment, and would usually involve taking an extended outage. Examples would be the replacement of contacts in a tap changing mechanism, or the replacement of a transformer bushing.

Schedules for maintenance should be developed based on equipment manufacturer's suggestions, the operating record, inspection results, past maintenance experience, the critical nature of the equipment and the shut-down schedule of the facility. Maintenance may be performed by the customer's own personnel, or a qualified contractor.

As part of the interconnection agreement, specific equipment will be identified and maintained by PSE&G (at the NUG's expense). The requirements for this type of maintenance are established by the need to maintain the integrity of the PSE&G System and prevent interference to other NUGs or customers. This maintenance must not be duplicated by the customer or his contractor. Coordination and communication between PSE&G and those doing the maintenance for the customer should be initiated.

4.7 Solar Loan Program

Meter Location

The Production Meter (Solar Renewable Energy Certificates (**SREC**) Meter) shall be in close proximity to the Revenue Meter; and a visible disconnect must be installed on both sides of the Meter. The Inverter is not considered and cannot be used as a visible disconnect. This Meter shall be the first piece of metering equipment after the Inverter on the AC Side. Consult with PSE&G Wiring Inspector.

Wiring

Current Transformer (**CT**) Polarity Marking shall face source.

Meter socket line-side shall be fed from Inverter (Single and Three-Phase, self-contained).

Inverter, Production, or SREC Meter Socket load-side shall be fed from the load-side of the Revenue Meter.

Signage

In addition to what is required by the NEC, PSE&G may require extra signage for the safety of our employees; consult with PSE&G Wiring Inspector for specific details.

Decommissioning Equipment

When the Loan has been satisfied, PSE&G will remove the Inverter, Production, or SREC Meter. The Customer will be required to remove the Inverter, Production, or SREC Current Transformers (CT) and replace with shunts or CTs.

Figure 9.1: Current Transformer Rated Solar Loan Configuration

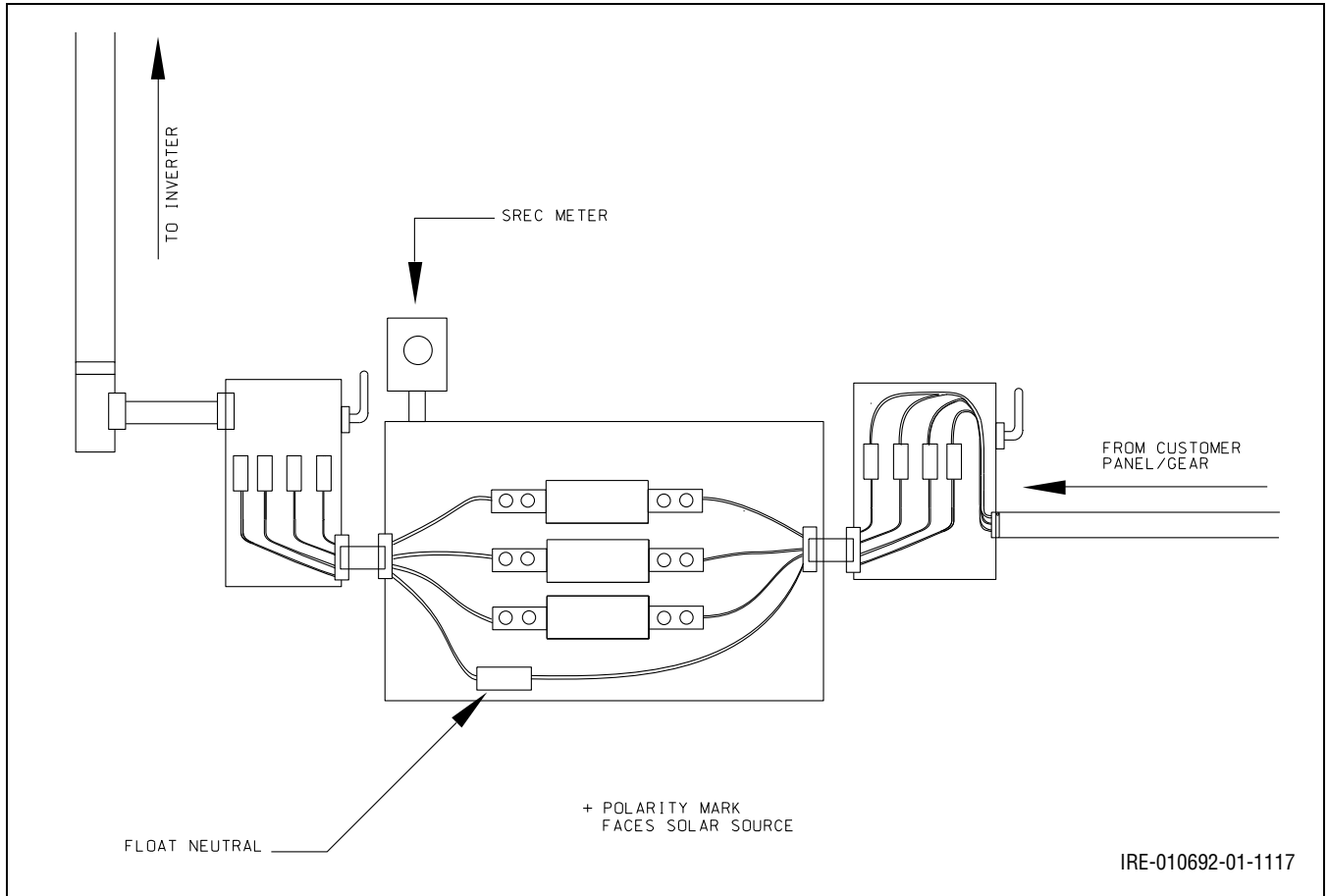
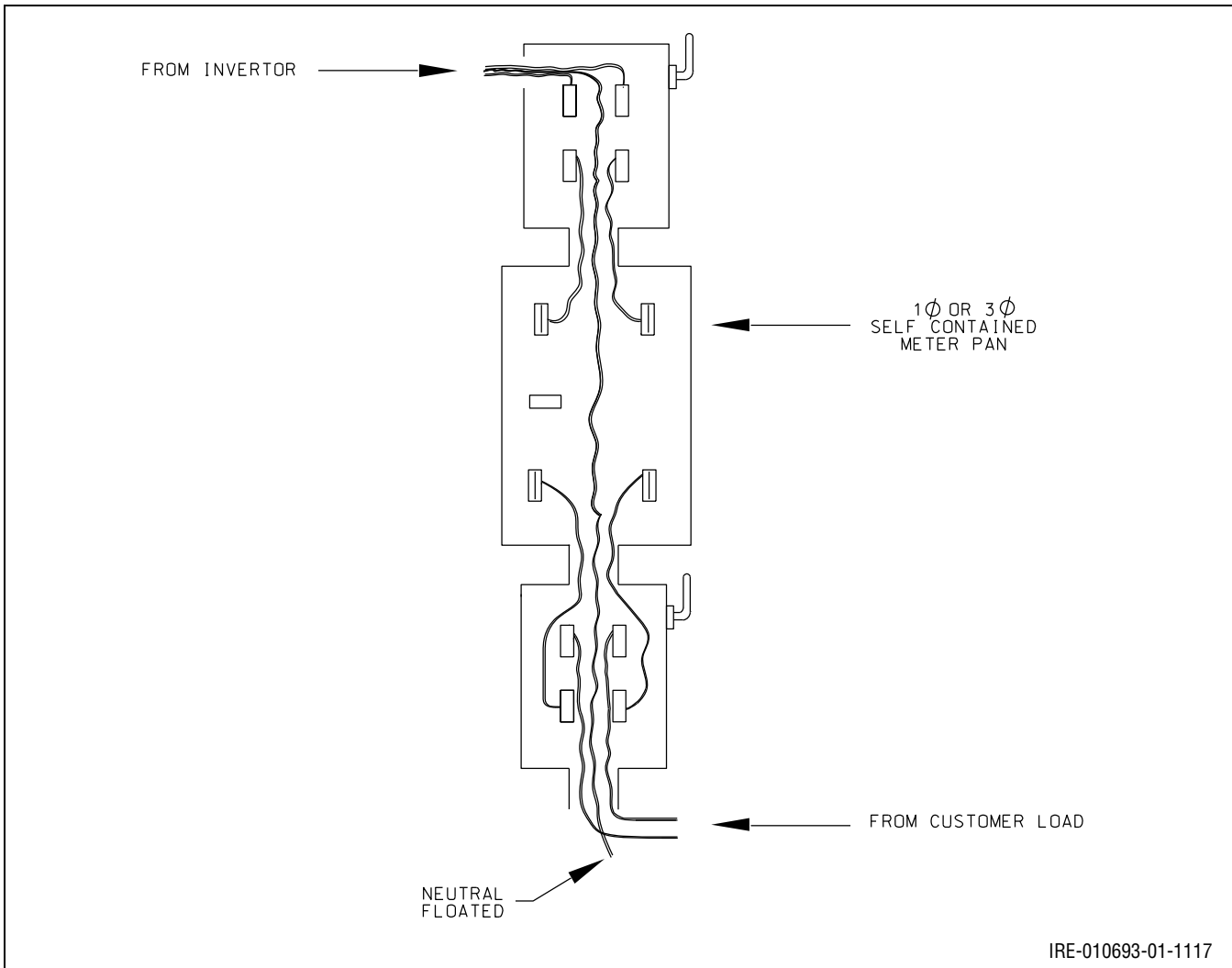

Figure 9.2: Self-Contained Residential Solar Loan Wiring Configuration



IRE-010693-01-1117

5 Renewable Generation in Network Areas (Level 3)

As per N.J.A.C. 14:8-5.4 For Level 1 Applicants – A customer-generator facility’s point of common coupling shall not be on a transmission line, a spot network, or an area network. Installing Renewable Generation in areas served by secondary or spot networks is complicated by the manner in which such networks operate. The PSE&G transformers that supply power to a secondary network are protected against backfeed by a device called a network protector. When the transformer is energized from the secondary, the network protector will trip the transformer secondary breaker upon backfeed with minimal time delay. An excessive number of operations of the protector will lead to premature failure.

Solar Photovoltaic System (PV System) developers need to be aware that installations in any urban city environment where underground distribution is present may involve Network Distribution Systems. Networks are high reliability distribution systems that are primarily used in PSE&G cities. If a developer scouts out a potential solar site in an urban city area and does not see overhead distribution on all of the streets in the immediate area of the prospective site, there is a very high probability that the site is in a network area.

5.1 Network Basics

Networks are special distribution systems that utilize two or more primary voltage feeders (either 26 kV, 13 kV or 4 kV) that are essentially connected in parallel. In a typical network, each feeder is connected to a special step down transformer called a Network Transformer. The Network Transformer is a submersible device that is placed in an underground vault and transforms the primary voltage to the service voltage, either 120/208 VAC three phase or 277/480 VAC three phase. Attached to each Network transformer is a device called a Network Protector. The Network Protector is a high capacity submersible circuit breaker. A Network Protector is controlled and protected by a microprocessor device called a Network Protector Relay. The Network Protector Relay is physically installed inside of the Network Protector. The output terminals of the Network Transformer / Protector are connected in parallel with one or more other Network Transformer / Protectors. A two circuit network may have two Network Transformer / Protectors connected in parallel. A three circuit network may have three Network Transformer / Protectors connected in parallel and so on. The point where all of the Network Transformer / Protectors are connected together is called the Network Bus. One or more services are connected and fed from this Network Bus.

5.2 Types of Networks

Networks come in two basic designs, the Spot Network and the Area Network. The Spot Network is typically used to feed a large building in an urban area, where all of the Network Transformer / Protectors and the Network Bus are located in a vault in front of the large building. The Spot Network will only feed this one large facility.

An Area Network is used to serve multiple smaller buildings and typically uses a distributed Network Bus. In an Area Network the Network Transformer / Protectors are not placed in a common vault but are located in two or more vaults spread around the network area. The Network Transformer / Protectors are connected together at the secondary voltage level via a cable bus. The individual customers are connected to this cable bus. The area network can be as large as depicted in [Figure 9.3: Area Network](#), which is shown with three rungs or as small as a single rung. Larger networks are more capable of absorbing the output of solar systems and distributed generators, within reason.

Figure 9.3: Area Network

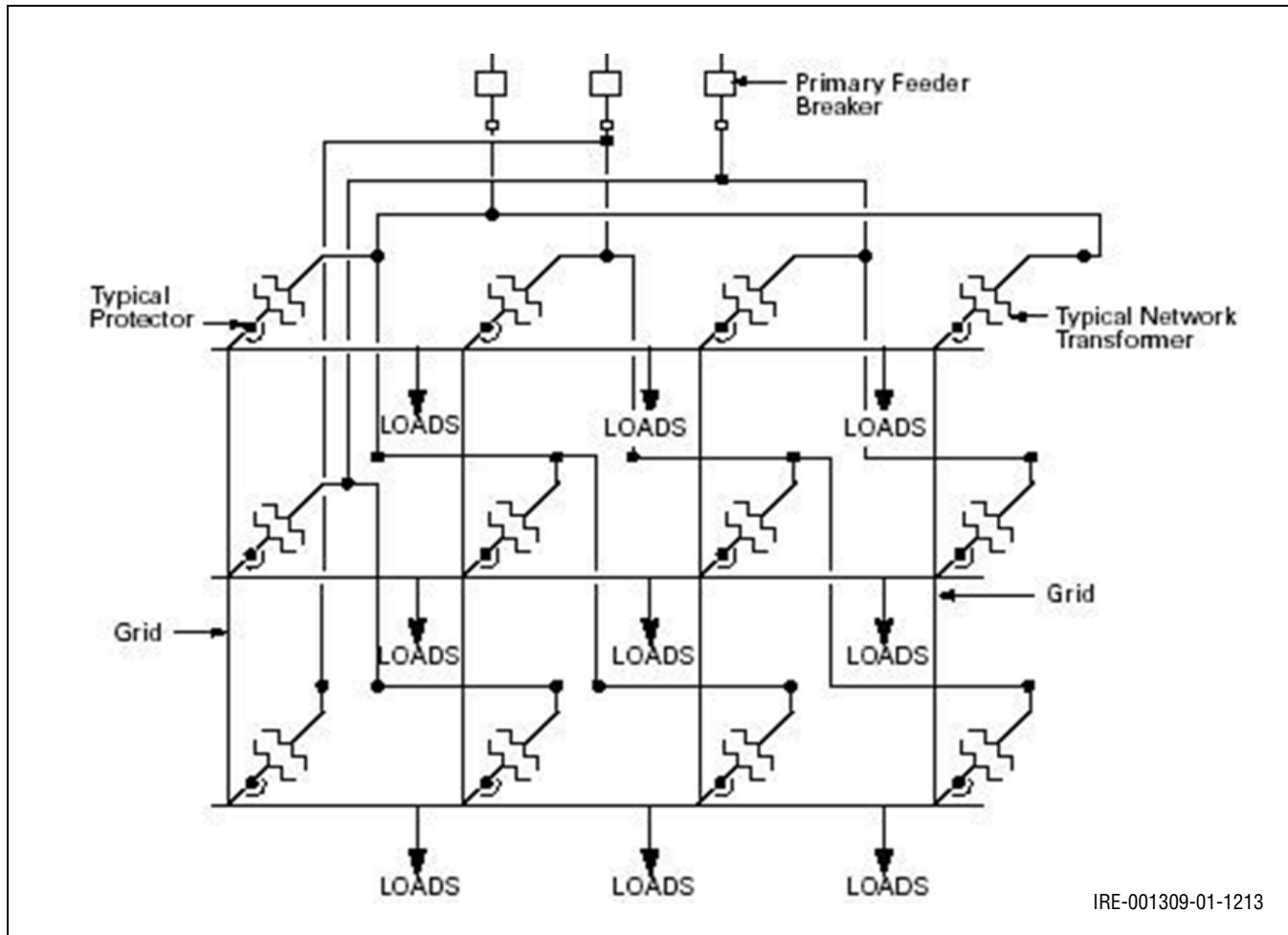

5.3 Network Interconnection Issues

Networks are designed to restrict back feed to the utility source. In a Solar System installation on a network system, the entire output of the Solar System must be absorbed by the load attached to the Network Bus. If the solar output exceeds the load at the facility, the excess power will begin to back feed which will cause the network protectors to open. At this point the customer will lose power.

The Network Protector and its Protective Relay are designed to detect and act on two types of back feed. First, “high level” back feed in a network occurs if there is a phase to phase or three-phase fault on any of the primary voltage network feeders. If a phase to phase or three-phase fault occurs on a primary voltage feeder, the Network Transformer / Protector detects the fault and immediately opens preventing the unfaulted feeders from back feeding through the Network Bus. This protective action occurs almost immediately with no interruption to the customer.

Secondly, “low level” back feed will occur if the source feeder becomes de-energized (most commonly caused by a ground fault on a source cable resulting in the opening of the utility station breaker). The Network Transformer / Protector will open after a time delay. In the case of a Solar System installation, if the solar output meets or exceeds the load it is connected to, then the Network Transformer/Protector will trip due to low level back feed.

Network systems were never designed to support Distributed Generation or any technology where there is a possibility for exporting power. Exported power looks like back feed current to the Network Protection Relay. All Network Protectors connected to the common low voltage bus will see reverse current and will open, causing the facility to lose power.

After the facility goes dark, the IEEE 1547 / UL 1741 compliant inverter will shut down and the Network Bus will be de-energized. At this point all of the Network Protectors feeding the solar facility have opened and the Network Protector Relays have ceased to detect reverse current. Since the Network bus is dead and the source feeder cables are hot, the network protectors will automatically begin to restore power to the Network Bus one at a time. As soon as one Network Transformer / Protector restores power to the Network Bus, the Solar System begins its auto-restart sequence. Many designs will automatically allow the inverters to restore the Solar System after receiving 5 minutes of normal power. At this point the Solar System once again begins to generate and will once again export power. The entire sequence will repeat and continue until the Network Protectors fail.

5.4 Potential for Export of Power

Solar Systems have the potential to export power when they are sized larger than the load of the facility they serve or are over 10- 20% of the normal minimum load demand of the facility they serve. Normally in an overhead radial environment this back feed or export is not an issue, but export in a Network environment is a major concern to all utilities. Back feed export for systems that are sized at about 10- 20% of the normal minimum load demand tend to export on very low load days, typically late spring and late fall (A/C not running) weekends. During these periods the facility loads are at their lowest levels and are at the greatest risk for a Solar System back feed.

To truly understand the electric energy usage of the facility, a real-time demand level study is required to eliminate any possibility of export, the Solar System must be sized to be less than real minimum demand. If this cannot be done or if the developer does not want to, the system must be equipped with a Minimum Import Relay. This would only be feasible on spot network facilities. This relay insures that there is some minimum power flow into the facility. When power import falls below the preset minimum, the relay trips the Solar System off line to prevent any possibility of export (resulting in a customer loss of power)

5.5 Codes Governing Connections to Networks

The New Jersey Administrative Code Subchapter 5 – Interconnection of Class I Renewable Energy Systems Sections 14:8-5.1 through 14:8-5.9 describe all of the current rules for interconnecting with a local electric distribution company in New Jersey.

§ 14:8-5.5 Level 2 interconnection review

Section 14:8-5.5 (l) 1 through 3, describe the requirements for interconnections with Networks. See following excerpt:

(l) If a customer-generator facility's proposed point of common coupling is on a spot or area network, the interconnection shall meet all of the following requirements that apply, in addition to the requirements in (c) through (k) above:

1. For a customer-generator facility that will be connected to a spot network circuit, the aggregate generation capacity connected to that spot network from customer-generator facilities, including the customer-generator facility, shall not exceed five percent of the spot network's maximum load;
2. For a customer-generator facility that utilizes inverter based protective functions, which will be connected to an area network, the customer-generator facility, combined with other exporting customer-generator facilities on the load side of network protective devices, shall not exceed 10

percent of the minimum annual load on the network, or 500 kW, whichever is less. For the purposes of this paragraph, the percent of minimum load for solar electric generation customer-generator facility shall be calculated based on the minimum load occurring during an off-peak daylight period; and/or

3. For a customer-generator facility that will be connected to a spot or an area network that does not utilize inverter based protective functions, or for an inverter based customer-generator facility that does not meet the requirements of (l)1 or 2 above, the customer-generator facility shall utilize reverse power relays or other protection devices that ensure no export of power from the customer-generator facility, including inadvertent export (under fault conditions) that could adversely affect protective devices on the network.

A clarification for Sub Paragraph 3 above

The term, “**inverter based protective functions**” in the context of Networks, is that the Inverter has the ability to measure the power flow into or out of the network and be able to throttle inverter output as not to export power under any circumstances. If the Inverter does not have the capability to do so, then the output of the Solar System must be kept within the constraints described in Sub Paragraphs 1 and 2 above, or a Minimum Import (Reverse Power) relay and associated circuitry must be used to sense and eliminate Network back feed by automatically tripping the Solar system.

If the Solar Developers Network installation cannot be satisfied by the rules described in § 14:8-5.5 Level 2 interconnection review, then the Developer may apply for a Level 3 interconnection review and described in the opening paragraph of Section 14:8-5.6 Level 3 interconnection review below:

§ 14:8-5.6 Level 3 interconnection review

(a) Each Electric Distribution Company (**EDC**) shall adopt a level 3 interconnection review procedure. The EDC shall use the level 3 review procedure for an application to interconnect a customer-generator facility that does not qualify for the level 1 or level 2 interconnection review procedures set forth at N.J.A.C. 14:8-5.4 and 5.5.

(b) The EDC shall conduct an initial review of the application and shall offer the applicant an opportunity to meet with EDC staff to discuss the application. At the meeting, the EDC shall provide pertinent information to the applicant, such as the available fault current at the proposed interconnection location, the existing peak loading on the lines in the general vicinity of the customer-generator facility, and the configuration of the distribution lines at the proposed point of common coupling.

(c) The EDC shall provide an impact study agreement to the applicant, which shall include a good faith cost estimate for an impact study to be performed by the EDC. An impact study is an engineering analysis of the probable impact of a customer-generator facility on the safety and reliability of the EDC’s electric distribution system. An impact study shall be conducted in accordance with good utility practice, as defined at N.J.A.C. 14:8-5.1 and shall:

1. Detail the impacts to the electric distribution system that would result if the customer-generator facility were interconnected without modifications to either the customer-generator facility or to the electric distribution system;
2. Identify any modifications to the EDC’s electric distribution system that would be necessary to accommodate the proposed interconnection; and
3. Focus on power flows and utility protective devices, including control requirements.

5.6 Minimum Import / Reverse Power Relays

PSE&G requires the use of a minimum import relay on Solar installations that meet the third criteria of 14:8-5.5 Level 2 interconnection review (see figure below). Under this design, the customer must always be receiving a minimal amount of power from the utility. This minimum number will generally be determined by the minimum setting on the protective relay. This protective function system must be designed, set and tested by the customer. Upon request, PSE&G will provide recommendations for the relay type, wiring, etc. Upon request, PSE&G may provide engineering and a setting calculation review if the customer installs a relay specified by PSE&G. If the customer chooses to install a relay that has not been recommended by PSE&G, PSE&G will not provide engineering or relay setting support. In all cases, PSE&G **must** be contacted prior to testing and may require a witness test prior to placing the Solar System in service. PSE&G **must** receive a copy of all relay setting and testing results prior to placing the unit in service. The customer shall certify that the minimum import relay was tested and is working as per the requirements set forth in this section.

Figure 9.4: Minimum Import Relay

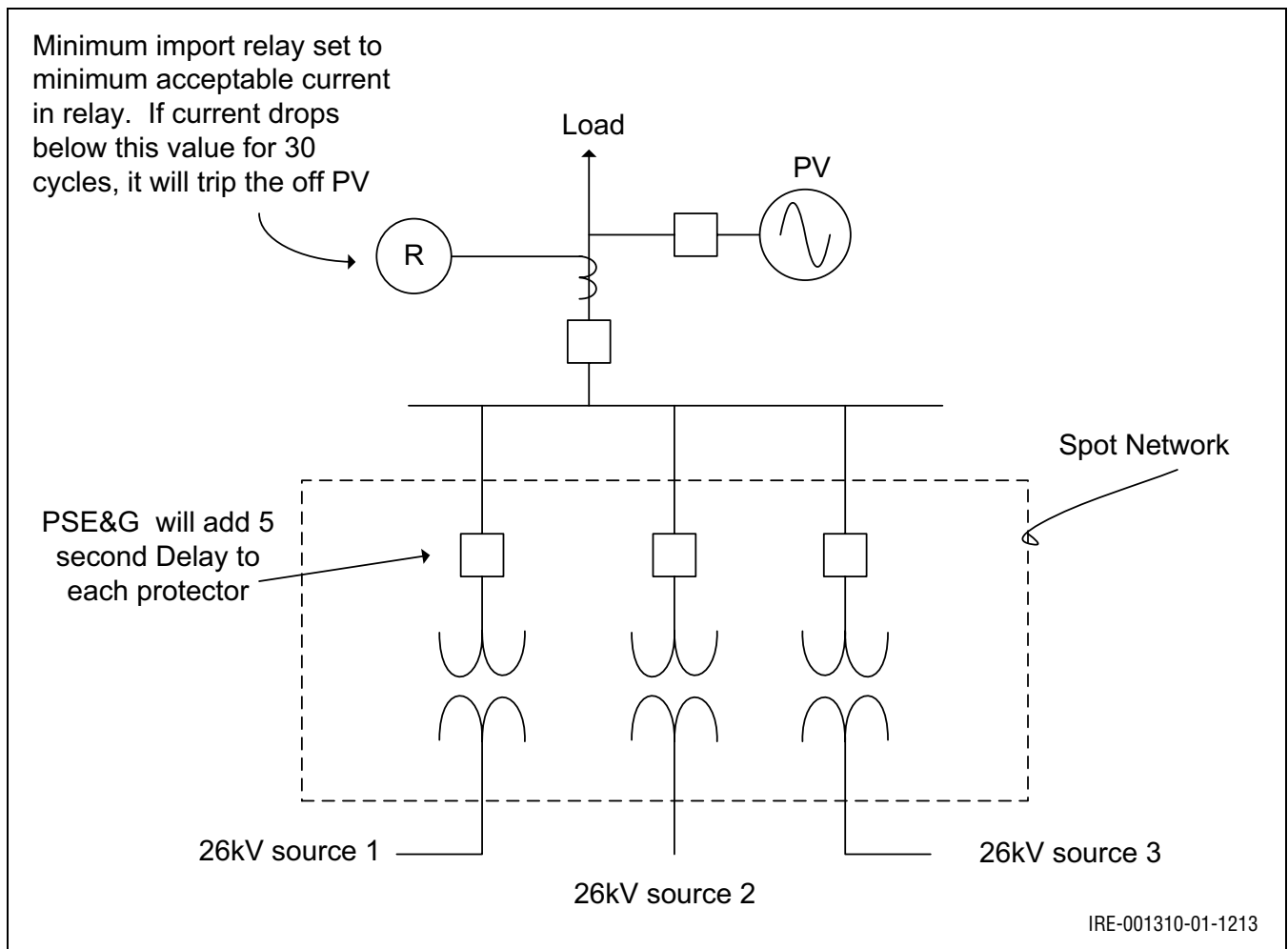

The minimum import relay must be designed and set to operate on each service phase connected to service entrance. It is the customer's responsibility to go through the proper channels to find the network service details for proper design including the service type, and network voltages. The relay shall be wired to trip the

generator (or Solar System) upon relay failure and loss of relay control power. The customer is expected to utilize a self-resetting contactor that drops out upon loss of control power to open the generator or Solar System.

Under no circumstances shall PSE&G assume responsibility for design flaws, setting errors or other deficiencies in the system that might result in undesired trips or equipment damage. Any damage to PSE&G equipment caused by deficient design, erroneous relay settings (even if reviewed by PSE&G) or any other failure to meet the requirements herein shall be the sole responsibility of the customer.

6 Additional Resources

- PSE&G Information and Requirements for Electric Service
https://www.pseg.com/business/builders/new_service/before/index.jsp
- Plant Engineering Policies and Procedures
https://www.pseg.com/business/builders/new_service/before/index.jsp
- Technical Support Contact
Michael.Henry@PSEG.com

Chapter 10 – Additional Information and Illustrations – Contents

1	Service Entrance Clearances	10-1
1.1	General	10-1
2	Grouped Meter Mounting Equipment Specifications	10-4
3	Outdoor Socket Overhead Secondary Service	10-5
4	Unacceptable Service Location	10-8
5	Indoor Enclosure Overhead Secondary Service	10-9
6	Service Entrance Mast – Galvanized Rigid Steel Conduit	10-11
7	Service Entrance Installations	10-12
8	Secondary Distribution Service Entrance – Underground Connections from Overhead Mains	10-13
9	Typical Conduit and Trench Details – BUD Installations Only	10-15
10	Specifications for Customer-Installed Underground Service Conduit – Overhead Zone	10-17
10.1	General	10-17
10.2	Construction Guidelines	10-20
11	Single-Phase, Two-Wire 120 V for Two-Wire Socket Meter	10-21
12	Single-Phase Three-Wire 120/208 or 120/240 V Three-Wire Socket Meter	10-23
13	Three-Phase, Three-Wire, 240 V Service – Ungrounded System	10-25
14	Three-Phase, Four-Wire Services	10-26
15	Grounding and Bonding	10-30
16	Approved Type Current Transformer Cabinet	10-36
17	Secondary Service Equipment with Bar Type Current Transformers (CTs)	10-40
18	Minimum Clearances and Bus Arrangement for Bar Type Current Transformers 200 to 800 A Secondary/Switchgear	10-44
19	Mounting Dimensions for Current Transformers in Cubicle – Window Type >801 A to 4000 A Secondary/Switchgear	10-46
20	Current Transformer Mounting Bracket Specifications and Dimensions	10-48
21	Service Runs	10-49
21.1	Secondary Connections to Terminals of PSE&G Equipment	10-49
22	Fiberglass Pad – Present Design Single-Phase	10-51
23	Secondary Conduit Connections for Single-Phase Open Delta Transformer	10-52
24	Single-Phase Padmounted Transformer – Open Delta Connections	10-53
25	Single-Phase Padmounted Transformer Pads	10-54
25.1	General	10-54

25.2	Location	10-54
25.3	Front Lot Pad and Enclosure Details	10-56
25.4	Concrete Pad Construction Details	10-56
26	Three-Phase Padmounted Transformers	10-57
27	Fiberglass Pad Three-Phase Padmounted Transformers (300 kVA and Below) – Type II	10-60
27.1	General	10-60
27.2	Location	10-60
27.3	Installation	10-60
28	Pad Construction Detail	10-62
29	Guide for Construction of Customer-Installed Transformer Vaults – Secondary Metered	10-66
29.1	General	10-66
29.2	Construction Specifications – For Overhead Type Transformers	10-66
29.3	Vault Requirements – Customer-Installed Transformer Vault – Construction’s Specifications Network Type Vaults Only	10-70
30	Minimum Requirements for a Temporary Service Mast	10-73
30.1	General	10-74
30.2	Construction	10-74
30.3	Working on Temporary Service Masts	10-75
30.4	Connections	10-75
30.5	Approvals	10-75
31	Underground Temporary Service Mast	10-76
32	Community Antenna Television (CATV)	10-78
33	Limiter Lug Assembly – 350 MCM and 500 MCM 600 V Rubber Insulated Service Cable	10-82
34	Net Metering	10-84
35	New Jersey One-Call System	10-86
36	Padmounted Transformer Installations – Secondary Metered	10-88

Chapter 10 – Additional Information and Illustrations

The information contained in this Chapter is for **illustration purposes only**, and can change at any time **without notification** to the user. **PSE&G must be contacted** by the user before proceeding with any work to verify that the version of a specific Drawing in this Chapter is still current, and to **obtain the latest copy** if it has changed. Any charges related to PSE&G furnishing and/or installing equipment or material shall be in accordance with [Chapter 1, Section 17](#) of this manual and the Tariff.

1 Service Entrance Clearances

1.1 General

Please note the following general requirements for service entrance clearances.

1. The Electrical Contractor should refer to the latest edition of this PSE&G document *Information and Requirements for Electric Service*, for general PSE&G requirements and consult the PSE&G Wiring Inspector for other information and interpretations.
2. All service entrance equipment shall be installed according to the requirements of State and local authorities, PSE&G, and the current edition of the *National Electrical Code (NEC)* and the *National Electrical Safety Code (NESC)*. Where clearance conflicts exist, the more stringent clearance is shown. The meter and service connection shall be located at a point jointly acceptable to the customer and approved by PSE&G wiring inspection, prior to the start of work.
3. If stack or group metering is to be installed see [Figure 10.2](#).

Figure 10.1: Minimum Clearances for Overhead Services

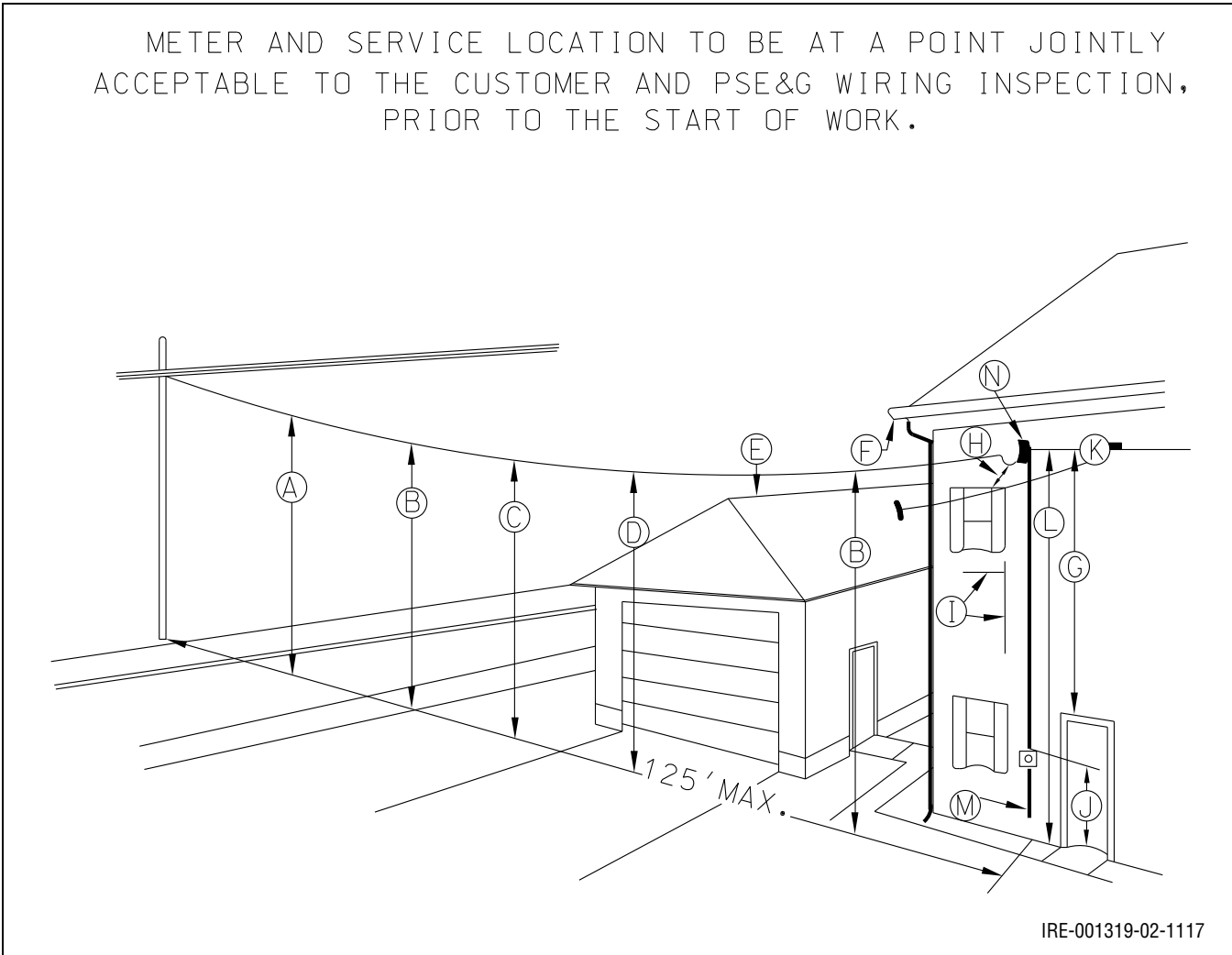

Figure 10.1 Notes:

Service Entrance Clearance	Distances
A. Public Street, Road, Alley, Parking Lots And Shopping Centers	18 ft
B. Sidewalks	12 ft
C Finished Grade	12 ft
D. Residential Driveway	12 ft
E. Roof Not Readily Walked Upon Roof Readily Walked Upon	3 ft 8 ft
F. Eavestrough or Downspout	3 in.
G. Door, Porch, etc., Beside and Below	3 ft***
H. Window Above to Service Entrance Conductors	6 in.
I. Beside and Below Window to PSE&G Service Drop	3 ft
J. Top of Meter Pan to Finished Grade	Min. 3 ft - 0 in. to top, Max. 6 ft - 6 in. to top.**
K. Telephone and CATV Bldg. Attachment	2 ft
L. Weatherhead to Finished Grade	Min. 13 ft - 0 in., Max. 30 ft - 0 in.
M. Where exposed cable is used, entry into building shall be 6 in. above grade.	
N. Weatherhead shall extend as much over 13 ft (Reference L) as is necessary to allow service drop to be attached below weatherhead and still maintain all necessary clearances	

Note

** "J" shall be 6 ft- 6 in. where sidewalks, walkways, driveways and/or blacktop is within 2 ft- 0 in. in front of meter pan. For 320 A meter pan, 6 ft from grade level to the middle of meter. Final Grade must be completed prior to final inspection.

*** "G" 3 ft clearance required on all installations. If outside, must have 3 ft clearance from face of meter to property line.

2 Grouped Meter Mounting Equipment Specifications

Figure 10.2: Exhibit 1 – Self-Contained, Single-Phase, Three-Wire 120/240V, 120/208V Network

Exhibit 1: Grouped Meter Mounting Equipment Specifications

SELF-CONTAINED, SINGLE-PHASE, THREE-WIRE 120/240V, 120/208V NETWORK

1. All sockets shall conform to the latest revision of ANSI-C12.7 Standards.
2. All approved grouped meter mounting equipment shall be UL approved and labeled.
3. A catalog number shall be on the front exterior surface and on an interior surface of approved equipment.
4. Each socket position shall have a continuous rating of no less than 100 A and no more than 200 A.
5. Each socket position shall have 5 tin plated copper jaws. By-pass horns with reusable insulating boots are permissible. By-pass horn connections must be accessible with the meter in place.
6. The 5th jaw shall be factory installed at the 9 o'clock position and be connected to the neutral with a copper #12 wire (minimum) or equivalent.
7. All socket positions shall have meter guides.
8. Automatic circuit closing devices are not acceptable.
9. Each socket positions shall have an individual ringless cover.
10. Covers for socket positions shall be securely closed by a non-removable, latching mechanism sealable with a barrel lock or padlock and a padlock seal or wire seal. Screws, nuts, wing nuts or removable hardware are not acceptable for fastening meter socket covers.
11. Ducts, compartments and raceways housing unmetereed conductors shall be sealable with an external tab for sealing with a barrel lock or padlock and a padlock seal or wire seal.
12. Covers shall be individually removable without unsealing, unlocking or removing adjacent covers.
13. Opening or closing meter socket covers shall not require tools other than keys for opening utility company locks and tools for removing and installing utility company seals.
14. The area behind the socket position shall be accessible only by removing the meter and/or socket cover and shall not be used as a raceway to accommodate metered conductors.
15. Metered and unmetereed conductors shall not occupy the same space except at the meter socket.
16. All meter socket positions in a vertical meter stack shall be identical in construction and application.
17. All electrical connections shall be welded or bolted using Belleville or equivalent washers.
18. A liberal coating of paste-type oxide inhibitor shall be on all bolted aluminum bus connections and on all terminal connections.
19. Each meter position shall be hot sequenced; that is, the meter shall be on the line side of the customer over current and disconnect devices.
20. Equipment for outdoor installation shall be weather resistant and rain tight. Meter sockets shall have passed Type 3R tests and shall be constructed to shed water without reliance on gaskets.

DIMENSIONS FOR GROUPED METERING EQUIPMENT

REQUIREMENTS:

- A. Minimum horizontal and vertical space between meter centers 9 in.
- B. Minimum distance lowest meter center from:
Floor 24 in. (indoor) and grade level 30 in. (outdoor)
- C. Maximum distance highest meter center from:
Floor 72 in. (indoor) and grade level 72 in. (outdoor)

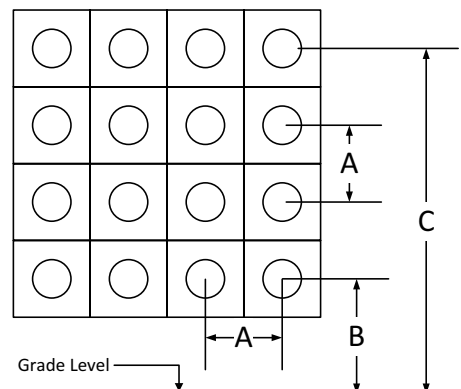

MWM-008778-01-0910

3 Outdoor Socket Overhead Secondary Service

Figure 10.3: First Floor Installation

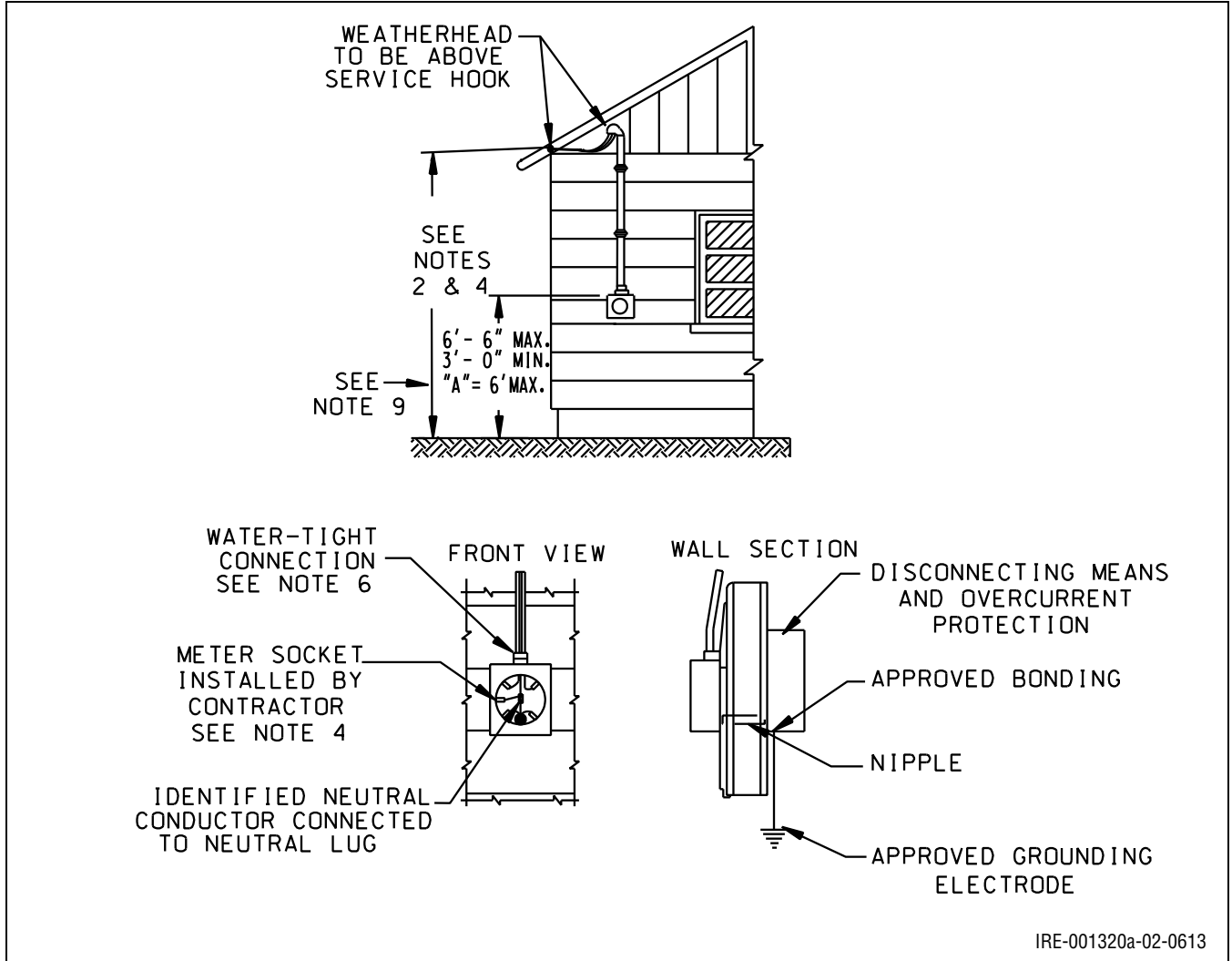

Figure 10.4: Panel Located in Basement

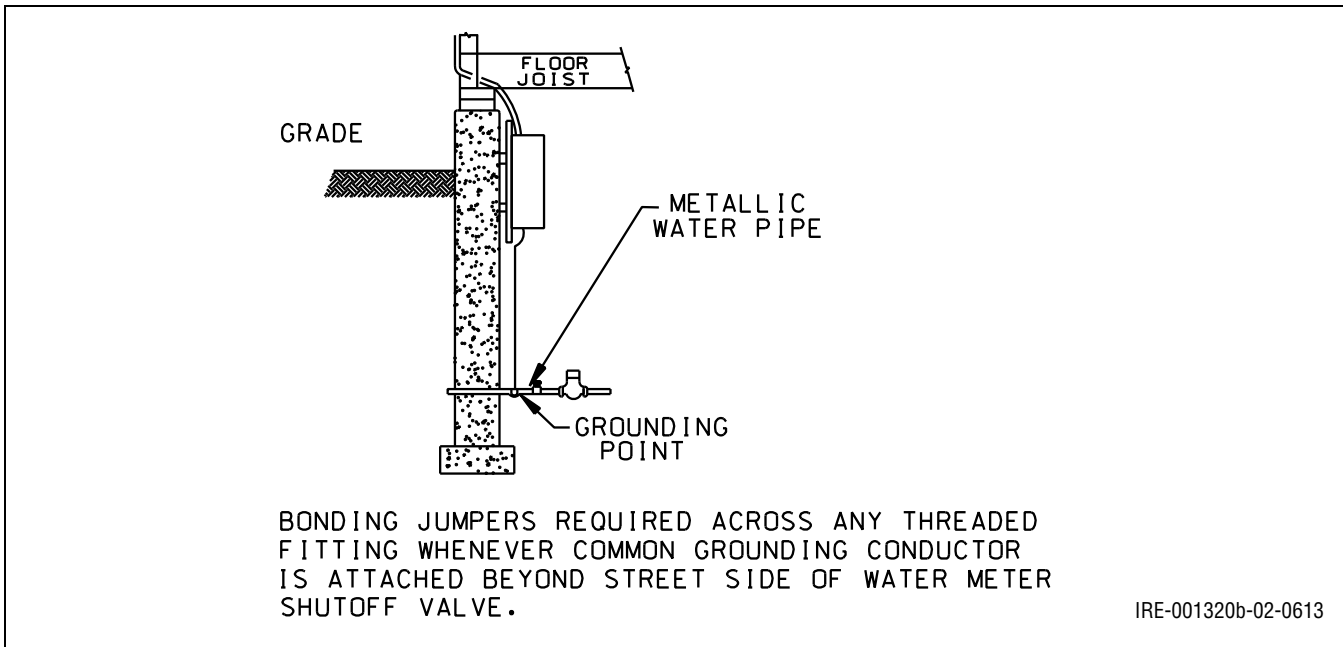

Figure 10.5: Grounding to Water System

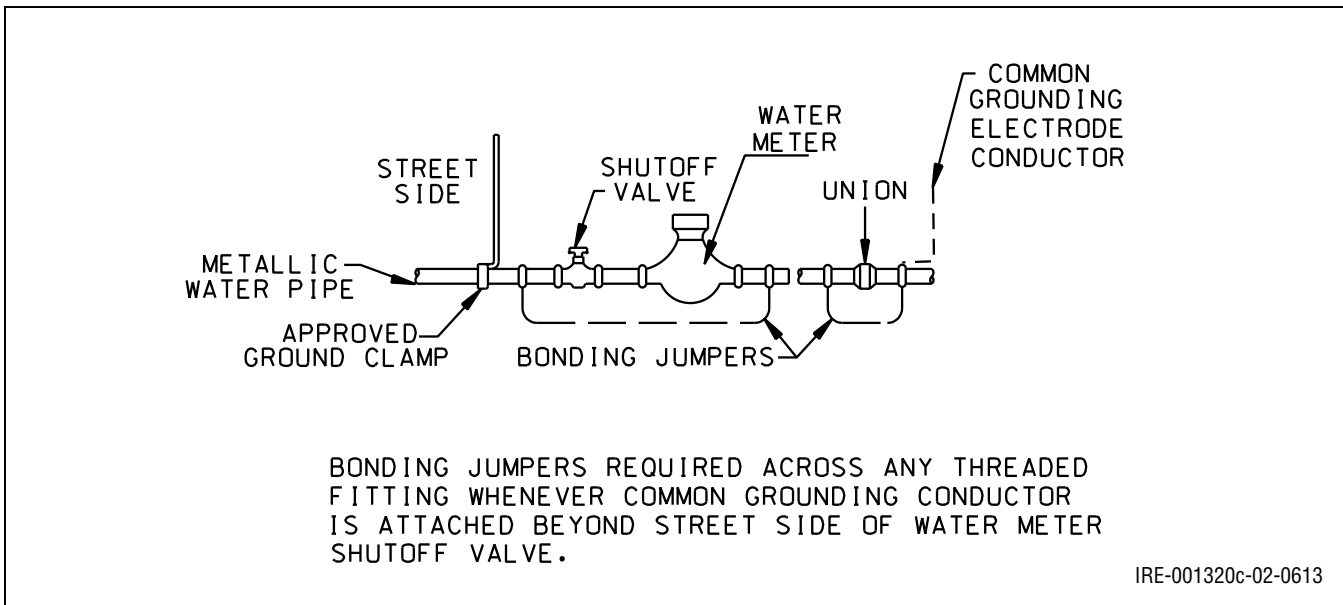

Figure 10.3, Figure 10.4 and Figure 10.5 Notes:

1. The electrical contractor should refer to the current edition of this PSE&G document *Information and Requirements for Electric Service* for general PSE&G requirements and consult the PSE&G Wiring Inspector for other information and interpretations.
2. All service entrance equipment shall be installed according to the requirements of State and local authorities, PSE&G, and the current edition of the NEC.

3. Common grounding electrode conductor shall be connected to a grounding electrode system as specified in Article 250 of the NEC except gas pipe shall not be used as a grounding electrode. No other utilities shall be attached to PSE&G equipment.
4. Minimum clearances for overhead services shall be in accordance with [Section 1 – Service Entrance Clearances](#).
5. The meter socket shall be fastened with screws in all mounting holes so that meter shall be level and perpendicular.
6. Where service entrance cable is used, make the threaded connector weather-tight with sealing compound or equivalent. If meter is inside and service cable is to be used, it must be sleeved in conduit, inside the building.
7. Where it may be exposed to mechanical injury, service entrance cable of the unprotected type shall be installed in conduit, electrical metallic tubing, or protected by other approved means. Portions of a service run less than 6 in. above grade level shall be considered as exposed to mechanical injury.
8. If copper and aluminum conductors are in the same terminal they should be separated with a listed barrier. All aluminum conductors shall be coated with an oxide inhibiting compound.
9. “A” dimension shall be 6 ft - 6 in. where walkway or driveway is within 2 ft - 0 in. of the front of the meter mounting.
10. The point of service connection must be workable from an extension ladder on grade level.
11. There shall be at least a 3 ft clearance in front of any meters. If outside, must have 3 ft clearance from face of meter to property line.
12. There shall be at least a 3 ft clearance between the electric meter pan and any gas metering. For propane gas, the clearance shall be at least 10 ft.

4 Unacceptable Service Location

Figure 10.6: Diagram of Typical Installation – Unacceptable Service Location

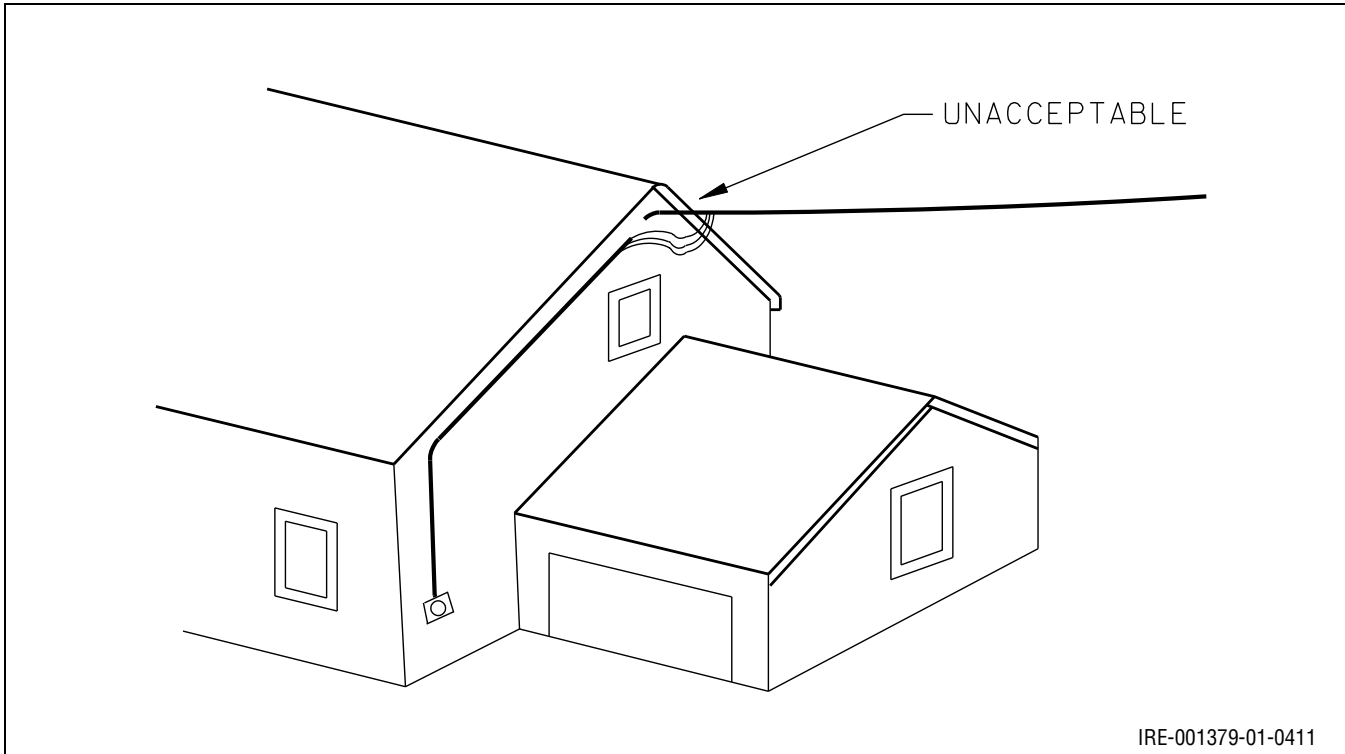

Figure 10.6 Notes:

1. A service attachment point located above a building extension represented as shown, is not acceptable because the service point cannot be directly reached with a ladder placed on the ground.
2. If an addition is added to an existing building, where it would result in the condition shown above, the service attachment point must be moved.

5 Indoor Enclosure Overhead Secondary Service

Figure 10.7: Non-Standard Installation – Special Approval Required – First Floor Installation

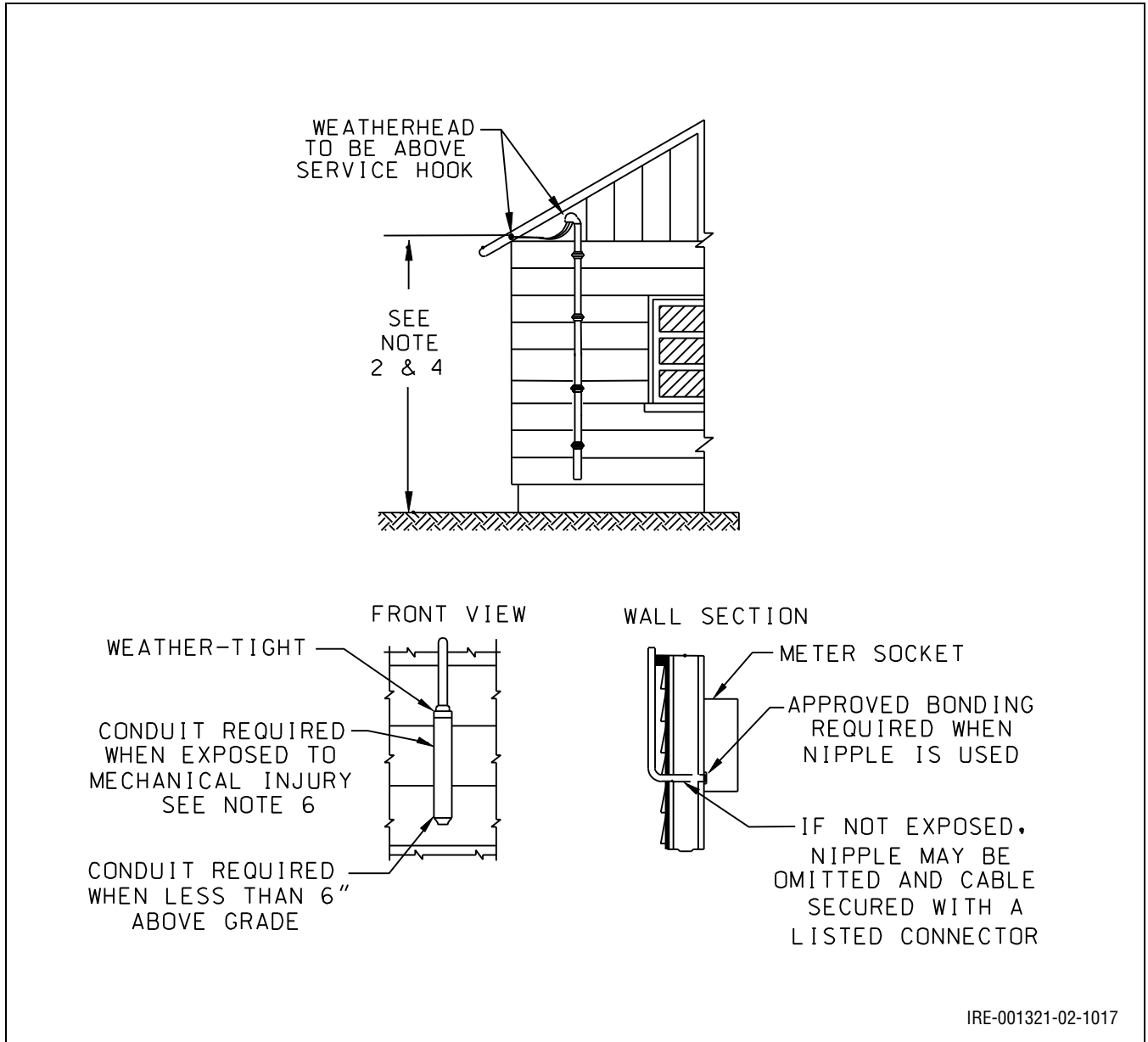

Figure 10.8: Non-Standard Installation – Special Approval Required – Basement Installation

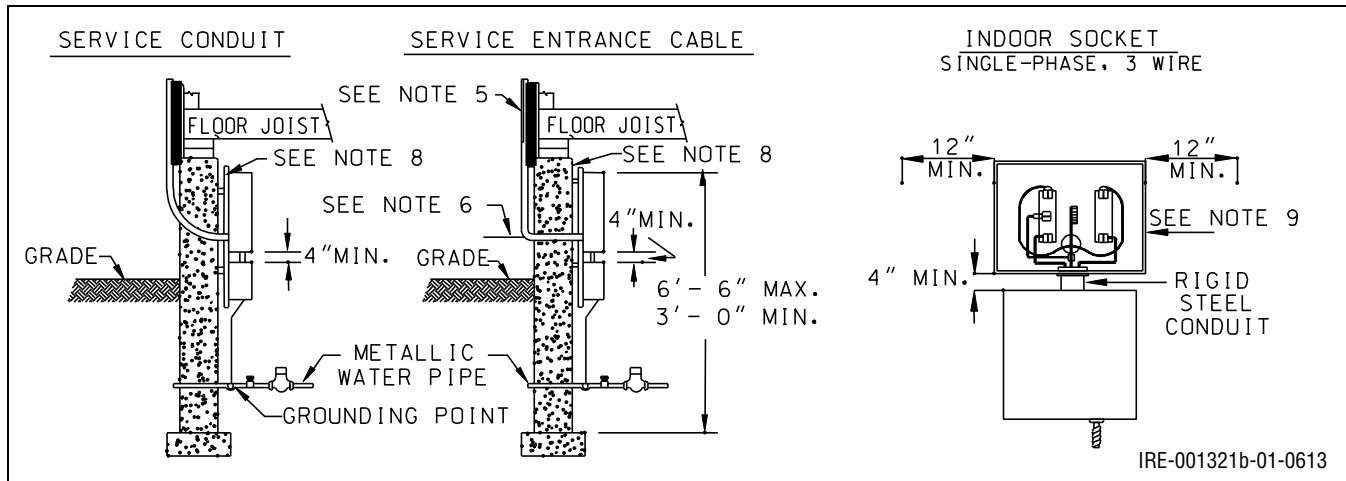

Figure 10.7 and Figure 10.8 Notes:

1. The electrical contractor should refer to the current edition of this PSE&G document *Information and Requirements for Electric Service* for general PSE&G requirements and consult the PSE&G Wiring Inspector for other information and interpretations.
2. All service entrance equipment shall be installed according to the requirements of State and local authorities, PSE&G, and the current edition of the NEC.
3. Common grounding conductor shall be connected to a grounding electrode system as specified in Article 250 of the NEC, except that gas pipe shall not be used as a grounding electrode.
4. Minimum clearances for overhead service installations shall be in accordance with [Section 1 – Service Entrance Clearances](#).
5. Where service entrance cable is used, make the threaded connector weather-tight with sealing compound or equivalent.
6. Where it may be exposed to mechanical injury, service entrance cable of the unprotected type shall be installed in conduit, electrical metallic tubing, or protected by other approved means.
7. Unmetered service entrance cable within a building, or where it is less than 6 in. above grade, shall be in conduit.
8. Meter boards of wood construction shall have a minimum of 1 in. air space from wall and shall be painted before metering equipment is mounted.
9. A clear working space shall be provided for each meter, and it shall have a minimum clearance of 3 ft in front of the meter face plate and 1 ft on each side of the meter pan; 3 ft clearance is required for all gas meter and any piping.
10. Fittings with removable plates are not permitted except by special permission from PSE&G, and if allowed, the plates must accept a seal.
11. If copper and aluminum conductors are in the same terminal, they should be separated with a listed barrier. All aluminum conductors shall be coated with an oxide inhibiting compound.
12. Meter sockets shall be equipped with barrel-lock provisions, and pre-approved by PSE&G before installation.
13. The point of connection for a service entrance must be workable from an extension ladder on final grade level.



Conduit Size	Maximum Height
2 in.	2 ft
2- 1/2 in.	4 ft
3 in.	7 ft

5. When back guying is required for heights exceeding those listed above, the following requirements shall apply:
 - Guy shall be securely fastened to anchored studding.
 - Guy wire shall be a minimum 1/4 in. galvanized wire
6. PSE&G assumes no responsibility for building damage associated with this type of construction.

7 Service Entrance Installations

Table 10-1 shall be used for determining sizes and types of un-guyed service entrance masts. The heights are given for the distance from the highest support to the point of attachment for size 2/0 or less service drop wires. The point of attachment will be a minimum of 6 in. below the service head.

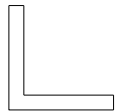
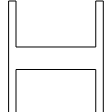
Table 10-1: Service Entrance Masts Specifications

MAXIMUM HEIGHT	GALVANIZED RIGID STEEL CONDUIT SIZE		ANGLE SIZE 	WEIGHT PER FOOT IN POUNDS	STRUCTURAL STEEL		I BEAM SIZE 	WEIGHT PER FOOT IN POUNDS
	SOLID CLEAR TIMBER SIZE	CHANNEL SIZE 			WEIGHT PER FOOT IN POUNDS			
2'	2"	4 X 6	--	--	4" X 1-5/8"	5.4	--	--
2'	2"	4 X 6	3" X 3" X 1/4"	4.9	6" X 2"	10.5	4" X 1-5/8"	7.7
3'	2-1/2"	4 X 6	3" X 3" X 3/8"	7.2	8" X 2-1/2"	13.75	5" X 3"	10.0
4'	2-1/2"	6 X 6	3-1/2" X 3-1/2" X 3/8"	8.5	9" X 2-1/2"	20.0	6" X 3-3/8"	12.5
5'	3"	6 X 6	3-1/2" X 3-1/2" X 7/16"	9.8	10" X 2-5/8"	20.0	6" X 3-3/8"	17.25
6'	3"	6 X 6	4" X 4" X 7/16"	11.3	12" X 3"	20.7	7" X 3-5/8"	20.0
7'	3"	6 X 6	4" X 4" X 1/2"	12.8	12" X 3"	25.0	8" X 4"	18.4
8'	--	--	5" X 5" X 3/8"	12.3	12" X 3"	30.0	8" X 4"	23.0
9'	--	--	5" X 5" X 7/16"	14.3	--	--	--	--
11'	--	--	5" X 5" X 1/2"	16.2	--	--	10" X 4-5/8"	25.4
12'	--	--	6" X 6" X 3/8"	14.9	--	--	10" X 4-5/8"	35.0

IRE-001323-01-0411

Table 10-1 Notes:

1. Service Entrance Masts shall be attached to building with through bolts that are adequately secured to the building structure.
2. A minimum of two bolts shall support a service mast.
3. The unsupported portion of the service entrance mast shall not be longer than the portion supported by the building. No couplings are permitted above the highest mast support point.
4. The contractor shall supply an insulator attached 6 in. below the service head on all rigid conduit masts.
5. The contractor shall supply a through bolt attached 6 in. below the height of the service head on a solid timber mast and conveniently located for attachment of the service drop.
6. The contractor shall furnish a 3/4 in. hole for all structural steel masts 6 in. below height of the service drop.
7. PSE&G shall determine the size and height of service masts for services larger than 2/0.
8. The above information covers PSE&G requirements only. Some municipalities may impose additional requirements

8 Secondary Distribution Service Entrance – Underground Connections from Overhead Mains

Figure 10.10: Service in Conduit

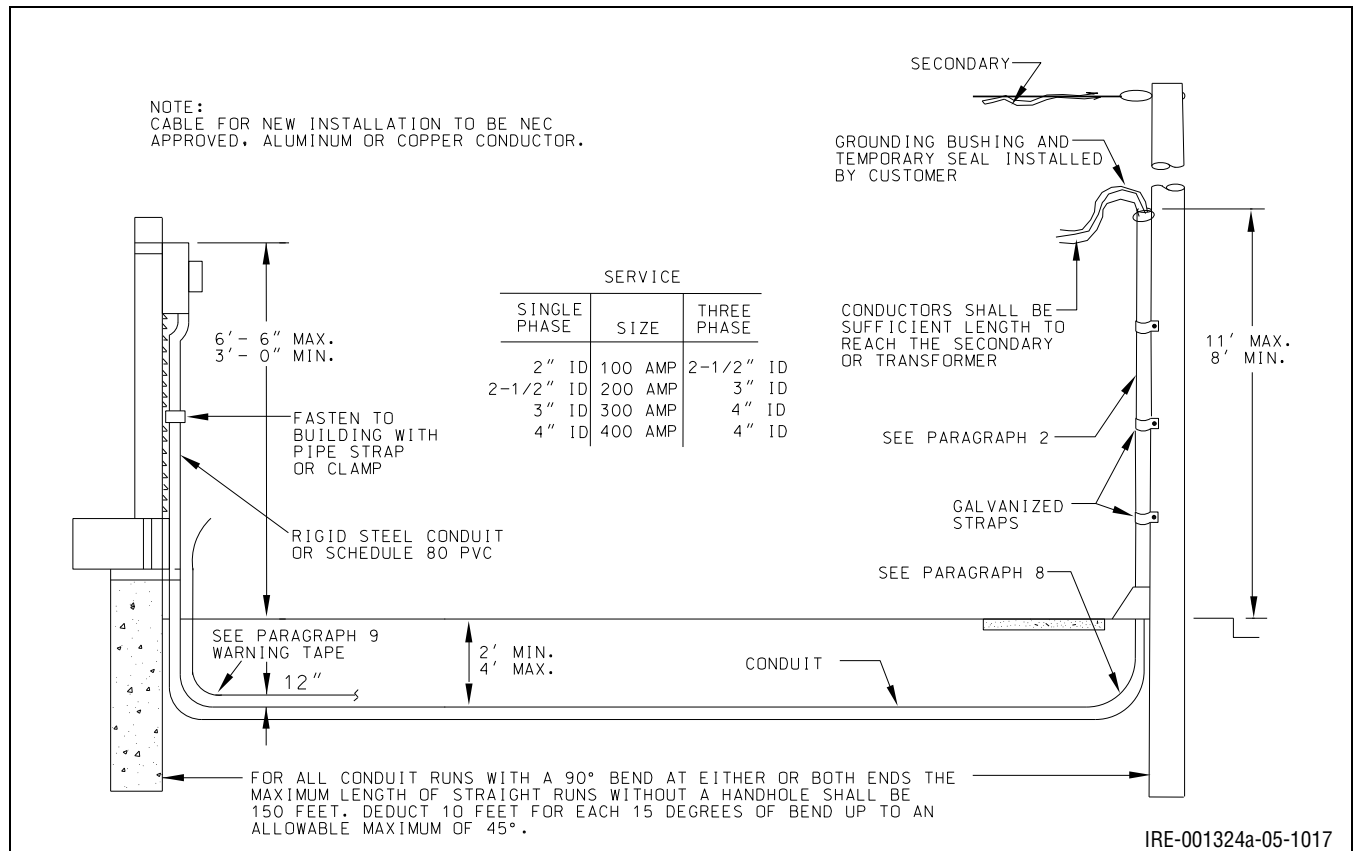

Figure 10.11: Direct Buried Service

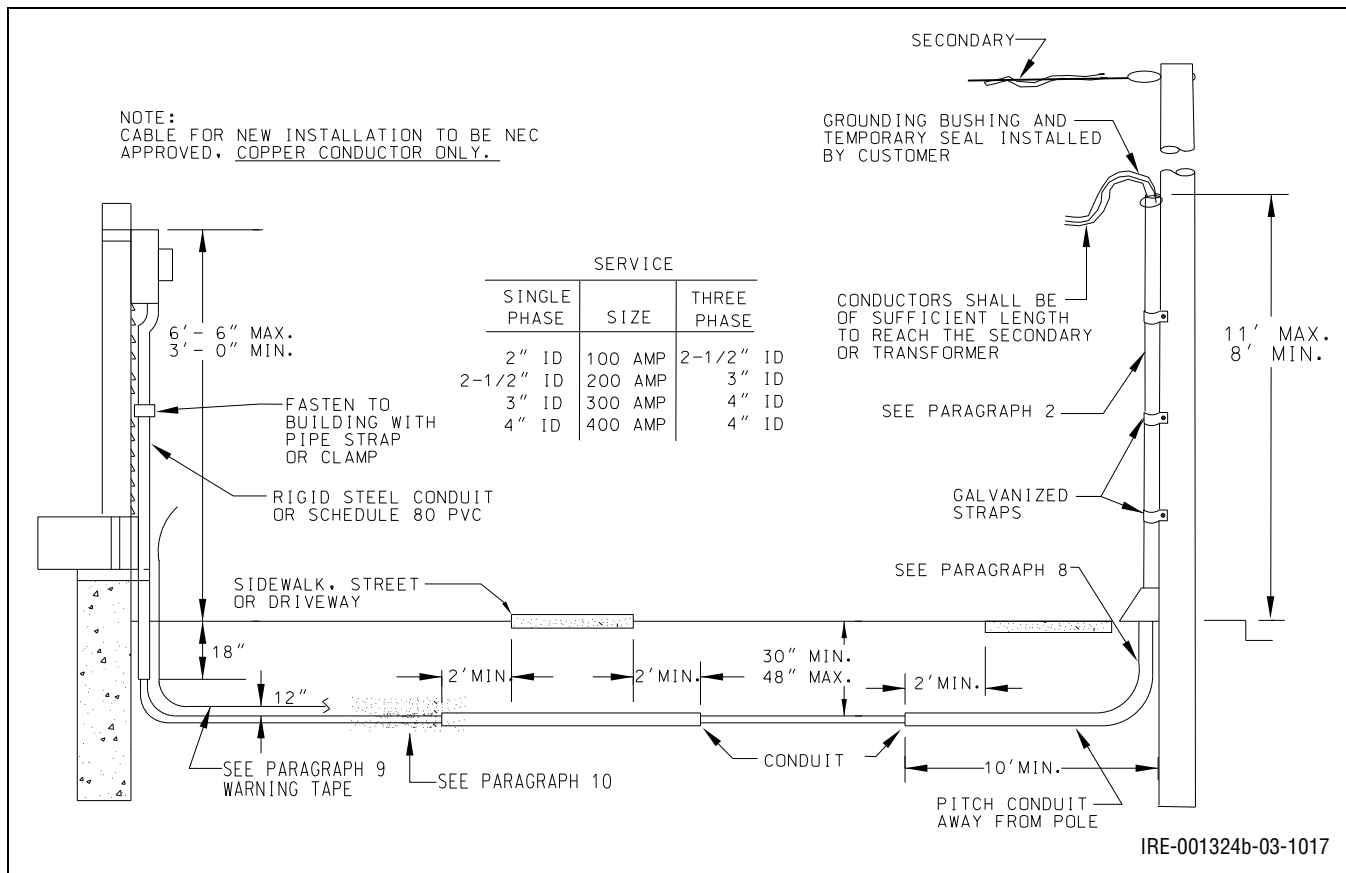

Figure 10.9 and Figure 10.10 Notes:

1. Grounding bushings shall be installed on the ends of rigid steel conduit.
2. Riser conduit shall be steel or schedule 80 electrical grade PVC.
3. A minimum of 12 in. of cable slack is required in meter pan.
4. See [Section 10](#) for detailed specifications.
5. Conduit used below grade shall be galvanized rigid steel, intermediate grade, or schedule 40 electrical grade PVC. If PVC is used then expansion joints shall be required at the building riser. Aluminum or HDPE shall not be used at or below ground for service runs to be maintained by PSE&G. **Conduit runs shall be constructed using only one material; either all galvanized rigid steel or all PVC.**
6. Conduit runs shall be a straight run from pole to meter allowing for one 90 degree bend at the pole and one 90 degree bend at the meter. The remainder of the run can allow for one bend between the pole and the meter that is no wider than 45 degrees.
7. Open trenching must be inspected by PSE&G and shall be scheduled in advance.
8. All conduit installations shall be inspected by a recognized electrical inspection authority and PSE&G before backfilling.
9. Underground service runs not encased in concrete shall have their location identified by a red warning ribbon that shall be placed in the trench at least 12 in. above the underground installation. This ribbon shall be of the "detectable" type, be at least 3 in. wide, and shall state "Caution Buried Electric Line"

Figure 10.13: Street Crossing

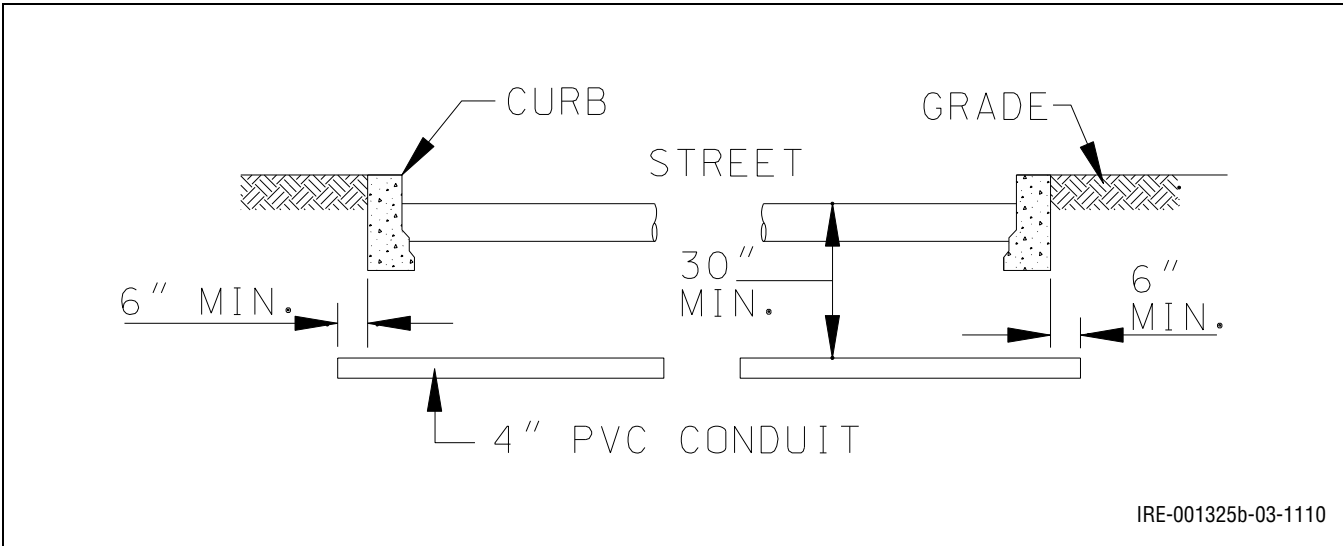

Figure 10.14: Standard Trenches

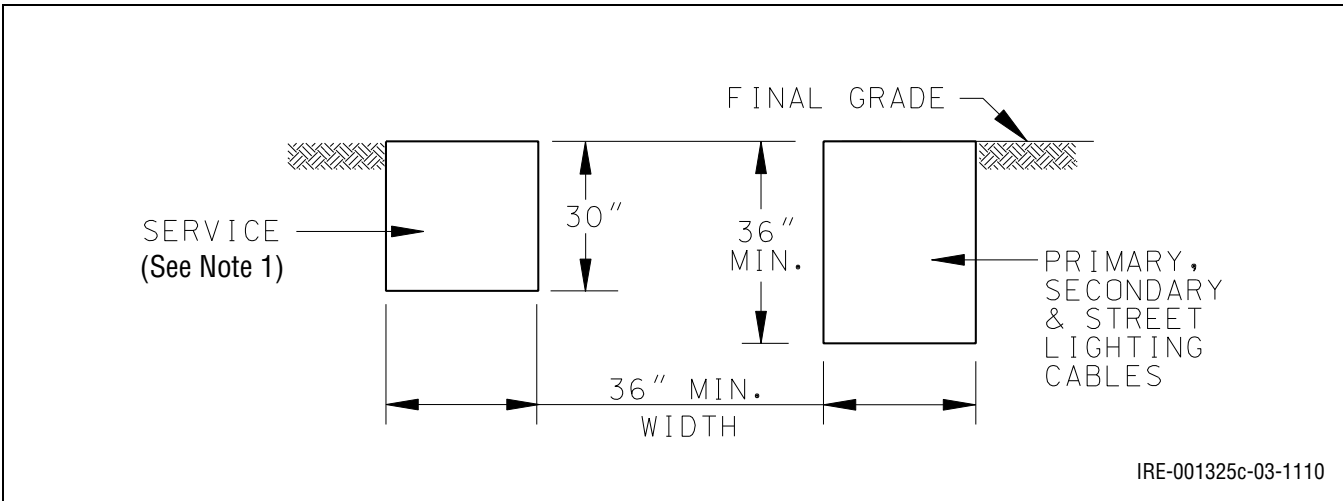

Figure 10.11, Figure 10.12 and Figure 10.13 Notes:

1. If area is not at final grade prior to trenching, this depth shall be 36 in. below the proposed final grade.
2. For meters installed inside buildings, and below grade, customer must supply and install conduit from meters to the transformer.
3. If PVC is used then expansion joints shall be required at building riser.

10 Specifications for Customer-Installed Underground Service Conduit – Overhead Zone

10.1 General

Please note the following general requirements for customer-installed underground service conduit.

1. Before any field construction starts, any proposed variations from these specifications must have specific written approval from PSE&G, and the Electrical Contractor must contact the PSE&G Wiring Inspector to arrange for the necessary inspections. Failure to do this could result in delay and the unnecessary expense of exposing conduit for the inspectors. The Electrical Contractor should refer to the following sources of information: The current edition of this PSE&G document *Information and Requirements for Electric Service* for general PSE&G requirements, and to the local PSE&G Wiring Inspector for details on each specific job.
2. Conduit used below grade shall be galvanized rigid steel, intermediate grade, or schedule 40 electrical grade PVC. If PVC is used then expansion joints shall be required at building riser. Aluminum or HDPE shall not be used at or below ground for service runs to be maintained by PSE&G. Conduit runs shall be constructed using only one material; either all galvanized rigid steel or all PVC.
3. All cut ends of conduit shall be reamed to remove rough edges. Grounding bushings are required on steel conduit.
4. The minimum conduit size shall be a minimum 1-1/4 in. for 60 A single-phase secondary service; 2 in. for 100 A single-phase and 2-1/2 in. for 100 A three-phase secondary service; 2-1/2 in. for 200 A single-phase and 3 in. for 200 A three-phase secondary service and 4 in. for primary service depending on the size of cable installed. Secondary lateral conduit shall extend to a minimum height of 8 ft or a maximum height of 11 ft above ground level, and can be either rigid galvanized steel or schedule 80 electrical grade PVC. See [Section 8](#) Primary lateral conduit shall terminate 6 in. above ground to facilitate the installation of a back plate and shield by PSE&G.
5. The conduit run shall have at least 24 in. of earth cover for secondary and 36 in. for primary. Trench depth shall not exceed 48 in., unless prior approval has been obtained from PSE&G. The conduit shall be pitched to drain away from the building.
6. The conduit shall be installed with a minimum number of bends. Refer to [Figure 10.10](#) and [Figure 10.11](#) – Note 6. Bends of rigid steel conduit shall be so made that the conduit will not become damaged and that the internal diameter of the conduit will not be effectively reduced.
7. Threadless couplings and connectors used with conduit shall be made water-tight. Where buried in masonry or concrete they shall be of the concrete-tight type, or where installed in wet locations, they shall be of the water-proof type.
8. The layout of primary conduit and handholes must be approved by PSE&G.
9. The radius of any conduit bend shall not be less than those listed in [Table 10-2](#).

Table 10-2: Minimum Radius of Conduit Bends

Conduit Diameter	Minimum Radius of Bends
1-1/4 in.	14 in.
1-1/2 in.	16 in.

Table 10-2: Minimum Radius of Conduit Bends (Cont'd)

Conduit Diameter	Minimum Radius of Bends
2 in.	18 in.
2-1/2 in.	24 in.
3 in.	36 in.
4 in.	36 in.
5 in.	48 in.

10. The customer shall submit two copies of a drawing showing the plan and elevation of the proposed conduit run including the handholes. The drawings shall be submitted to the local Electric Distribution Division office **before starting construction**. One drawing will be returned with comments or approval.

No advance approval for conduit construction will be given to the Electrical Contractor prior to his submitting such specific information as length of straight conduit segments, horizontal bend angle and horizontal bend radius.

11. Where a handhole is required for pulling in one or two sets of secondary cables 500 kcmil or smaller, the customer shall install a PSE&G standard 28 in. x 30 in. handhole. Handholes shall be concrete. This handhole may be used for light traffic areas such as driveways and parking lots, but it shall not be located in streets. The drawings listed in [Table 10-3](#) may be obtained from a representative of the local Electric Distribution Division office.

Table 10-3: Handhole Drawings for Secondary Cables

Item	Drawing Number
Handhole	DU-12-S-5201
Frame	DU-11-M-5135
Cover	DU-11-M-5136

12. The conduit for secondary cable shall enter the handhole in the center of the short walls, with its center line 27-1/2 in. below grade. When two conduits enter the handhole, they shall do so on 6 in. horizontal centers. No pulling irons are required; see paragraph 20.

13. Where a handhole is required for pulling in primary cable, the customer shall install a standard 28 in. x 60 in. handhole; however, larger manholes may be required in special cases. Primary cable shall enter in through 28 in. wall of the handhole. This handhole may be used for light traffic areas such as driveways and parking lots but it shall not be located in streets. The drawings listed in [Table 10-4](#) may be obtained from the local Electric Distribution Division office.

Table 10-4: Handhole Drawings for Primary Cables

Handhole Size	Light Traffic	Type	Handhole Size	Sidewalk	Type
28 in. x 60 in.	Handhole	DU-12-S-8282	28 in. x 60 in.	Handhole	DS-12-S-5342
	Frame	DU-12-M-8283		Frame	DU-12-M-5341
	(2) Covers	DU-11-M-5136		(2) Covers	DU-11-M-5136

14. The conduit for primary cables shall enter the handhole in the center of the short walls with its centerline 33 in. below grade. When two conduits enter the handhole, they shall do so on 6 in. horizontal centers. A pulling iron shall be installed in the center of each entrance wall opposite a conduit entrance, 6 in. above the centerline of the conduit; see paragraph 20.
15. The maximum size cables to be installed in a 28 in. x 60 in. handhole shall be: 4 kV, 750 kcmil, rubber insulated; and 13 kV, 2/0 polyethylene insulated, with a protective jacket.
16. There shall be a minimum of 12 in. of earth separation between the electric cables or conduit and any other subsurface utilities such as gas, telephone or cable. Electrical conduit shall not be cast in the same concrete envelope with any other subsurface pipes.
17. No more than two electric riser conduits shall be installed on a pole. If two electric conduits are installed on a pole they shall be as close together as the mounting straps permit. Riser conduit shall be installed on the quarter of the pole specifically designated by PSE&G for this purpose.
18. Where the supply line is on the opposite side of the street, PSE&G will install the service pole on the customer's side of the street and extend the overhead supply across the street. If an overhead crossing is impractical, PSE&G will install an underground crossing at the customer's expense (including street opening permit fees) including, if required, a handhole or manhole in the sidewalk area on the customer's side of the street. If approved in advance, under certain circumstances, it may be acceptable for the customer to have his contractor install the street crossing conduit and the curb line handhole or manhole.
19. A grounding bushing shall be installed on the metallic conduit ends at the pole riser and in the building or transformer pad. Where metallic conduit is used in manholes and handholes, the conduit shall be extended in the hole for a distance of 1-1/2 in. for attachment of the ground bushing, and a 1/0 copper bonding-jumper shall be installed between all the grounding bushings on each side of the handhole or manhole.
20. No more than three phase conductors and one neutral conductor shall be installed in a conduit. ISO-phasing is not allowed. Neutrals shall be insulated and the same size as the conductors. Separate grounds are not permitted in the conduit.
21. All conduit installations shall be inspected by a recognized electrical inspection authority and PSE&G before backfilling.
22. Where cables are to be installed by PSE&G, all customer-installed conduits shall contain an adequate pull line installed by the customer and firmly secured at both ends. This pull line shall be either 1/4 in. nylon, or 1/4 in. polypropylene rope.

23. A tag made of corrosion resistant material showing the house number of the service shall be secured to the top of the pole riser, or to the individual service runs if they are installed in a handhole.
24. When a conduit enters a box or other fittings, a bushing shall be provided to protect the conductor from any abrasion unless the design of the box or fitting is such as to afford equivalent protection.
25. Where underground service conduits are necessary for service from PSE&G's Subtransmission system, specific conduit requirements shall be obtained from PSE&G.

10.2 Construction Guidelines

Please note the following construction guidelines.

1. These guidelines are established to assist customers in the design and layout of conduit systems that will be used and maintained by PSE&G. They are not used for PSE&G's own conduit design and layout.
2. These guidelines are to be used when the size of the cable to be installed does not exceed 500 kcmil at 600 V or 4 kV, or 2/0 at 13 kV. When these cable sizes are exceeded, the conduit plans require special PSE&G approval.
3. The sum of all horizontal bend angles in a conduit run shall not exceed 135 degrees.
4. Underground service runs **not** encased in concrete shall have their location identified by a red warning ribbon that shall be placed in the trench at least 12 in. above the underground installation. This ribbon shall be of the "detectable" type, be at least 3 in. wide, and shall state "**Caution Buried Electric Line Below**" (Ideal 42-201 or similar product). Tape shall be visible at the exit points of the service from the ground, where applicable.

11 Single-Phase, Two-Wire 120 V for Two-Wire Socket Meter

Figure 10.15: Single-Phase, Two-Wire 120 V for Two-Wire Socket Meter

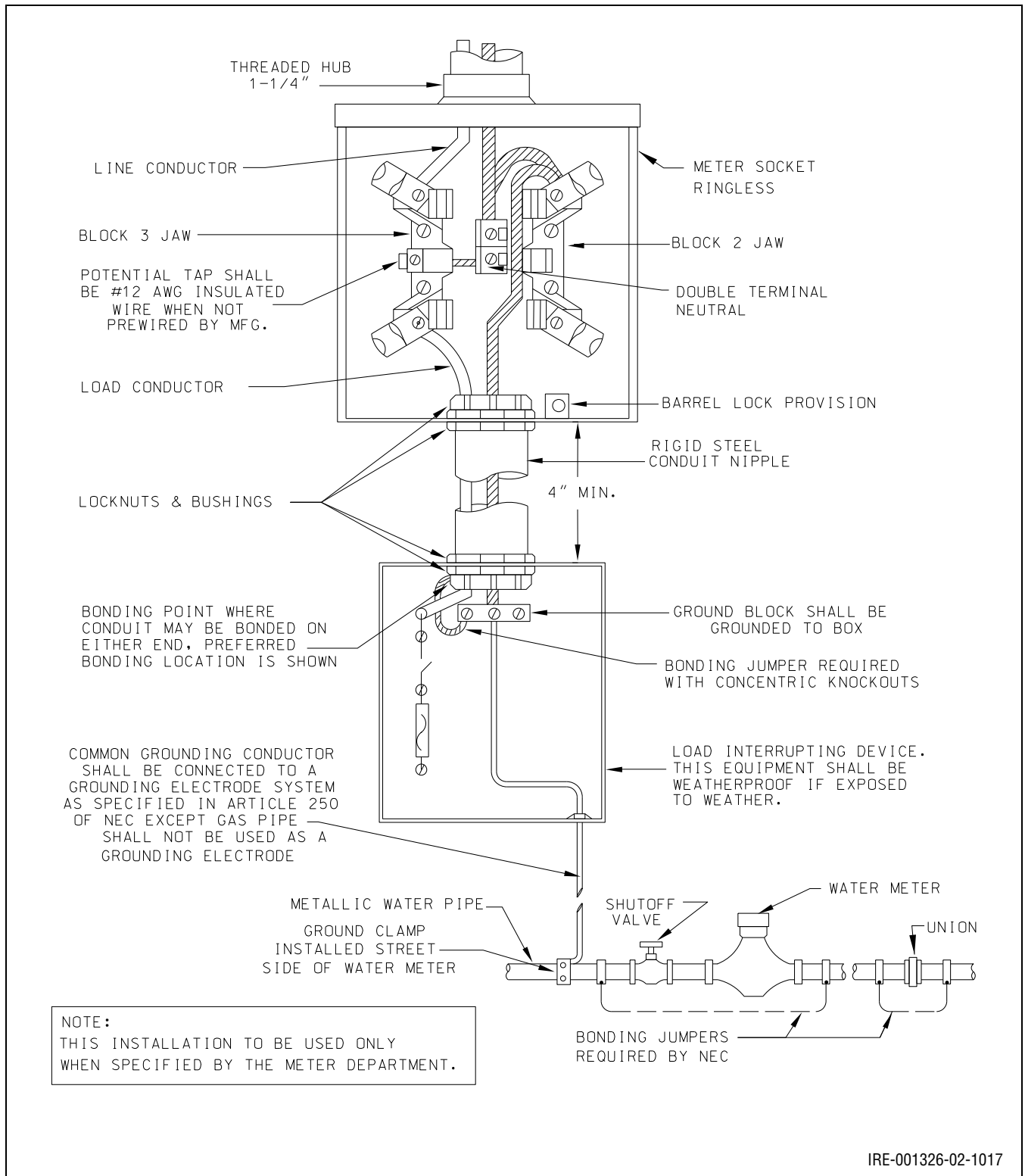

Figure 10.15 Notes:

PSE&G will:

1. Designate location of service equipment.
2. Furnish and install service drop conductors to the point of connection and install the meter.

Customer shall:

1. Furnish and install the service entrance equipment in accordance with the requirements of the NEC and PSE&G.
2. Use an approved oxide inhibiting compound on aluminum conductors.
3. Obtain an electrical inspection certificate from a recognized electrical inspection authority.
4. Meter pan must have a bypass horn, fifth jaw and barrel lock provisions.

12 Single-Phase Three-Wire 120/208 or 120/240 V Three-Wire Socket Meter

Figure 10.16: Single-Phase, Three-Wire, 120/208 or 120/240 V Three-Wire Socket Meter

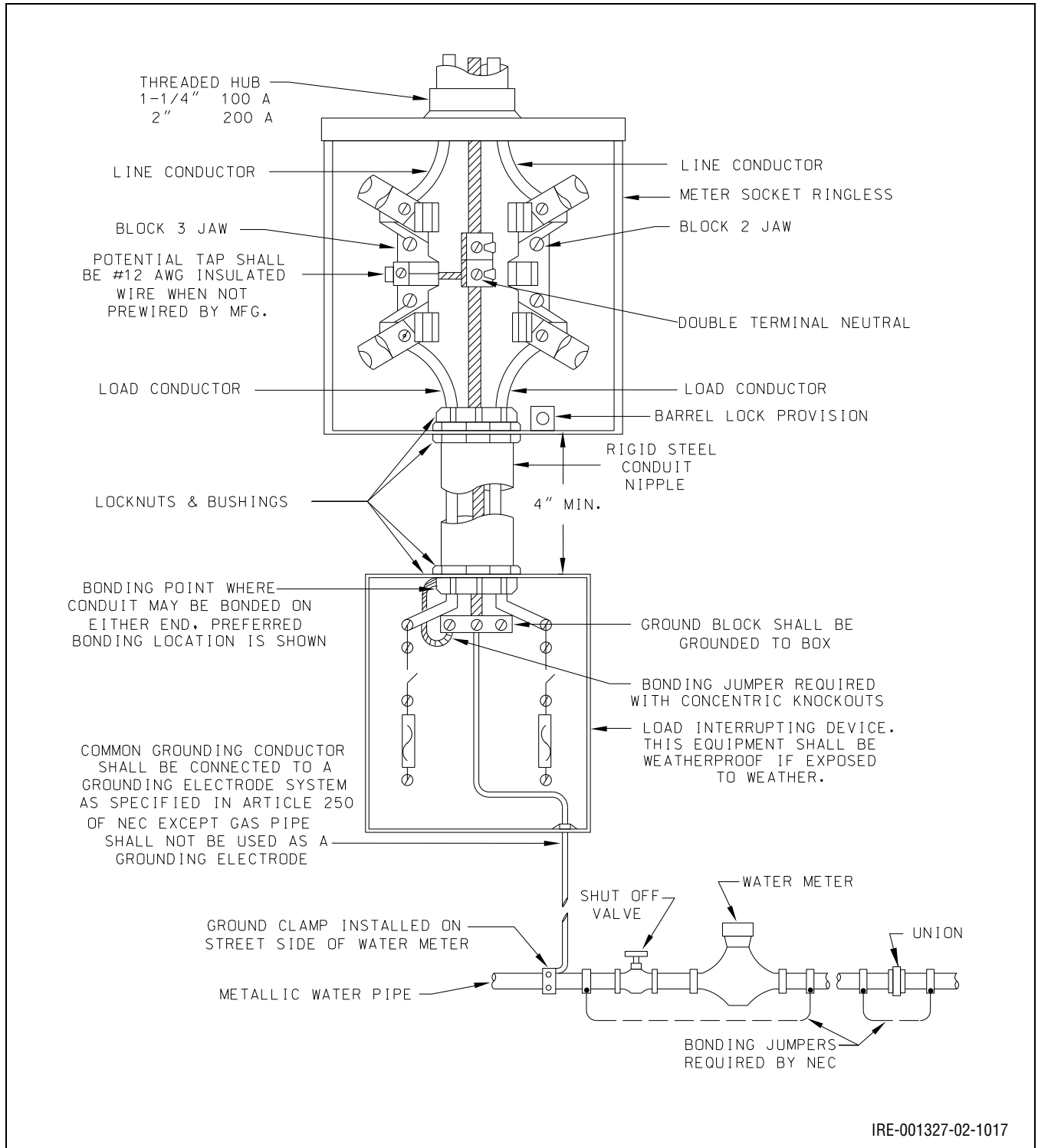

Figure 10.16 Notes:

PSE&G will:

1. Designate location of service equipment.
2. Furnish and install service drop conductors to the point of connection and install the meter.

Customer shall:

1. Furnish and install the service entrance equipment in accordance with the requirements of the NEC and PSE&G.
2. Use an approved oxide inhibiting compound on aluminum conductors.
3. Obtain an electrical inspection certificate from a recognized electrical inspection authority.
4. Meter pan must have a bypass horn, fifth jaw, and barrel lock provisions.

13 Three-Phase, Three-Wire, 240 V Service – Ungrounded System

Figure 10.17: Three-Phase, Three-Wire, 240 V Service – Ungrounded System

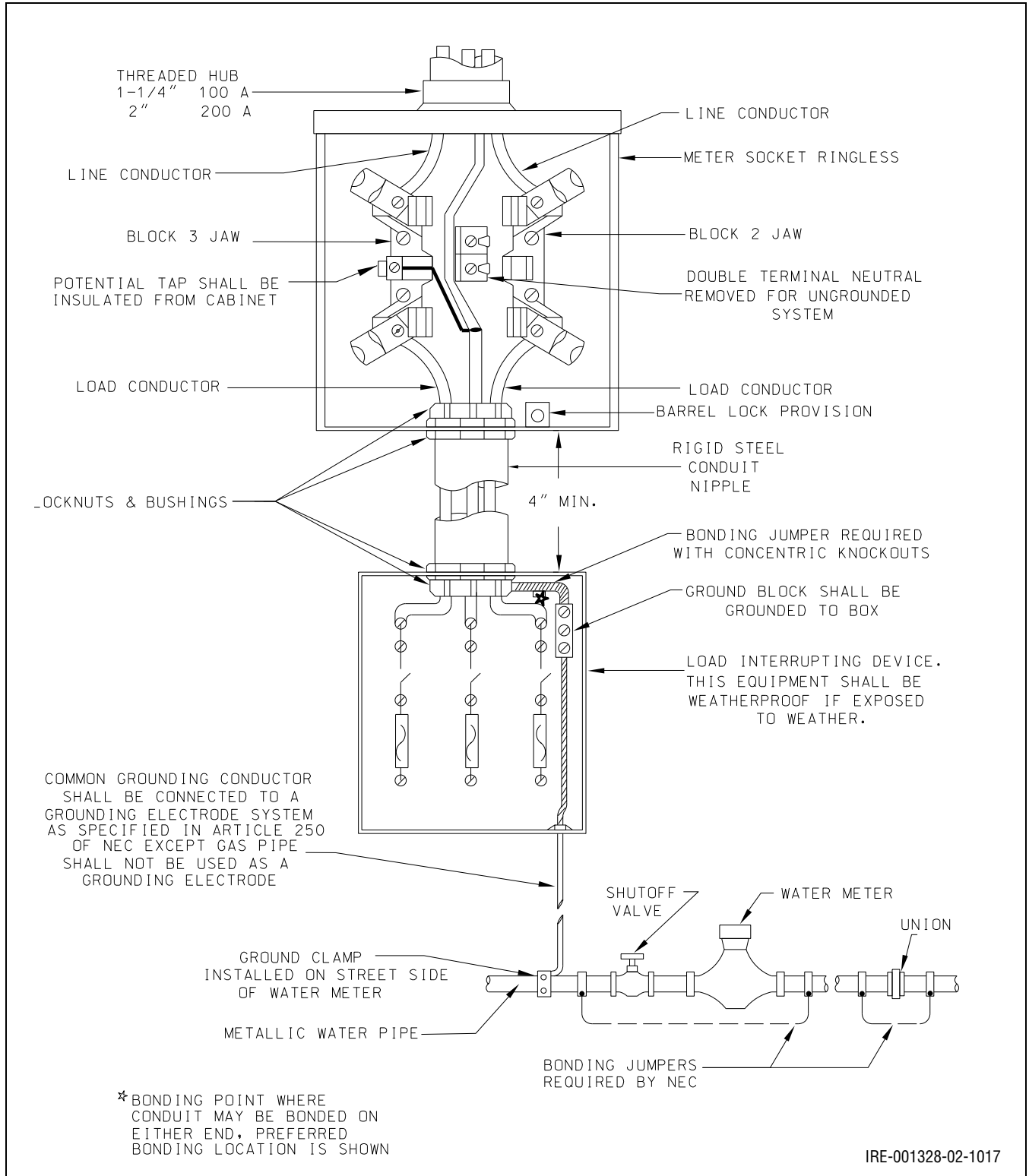

Figure 10.17 Notes:

PSE&G will:

1. Designate location of service equipment.
2. Furnish the meter socket, either 100 A or 200 A.
3. Furnish and install service drop conductors to the point of connection and install the meter.

Customer shall:

1. Furnish and install the service entrance equipment in accordance with the requirements of the NEC and PSE&G.
2. Use an approved oxide inhibiting compound on aluminum conductors.
3. Obtain an electrical inspection certificate from a recognized electrical inspection authority.
4. Meter pan must have a bypass horn, fifth jaw, and barrel lock provisions.

14 Three-Phase, Four-Wire Services

[Figure 10.18](#) applies to the following:

1. Three-phase – four-wire 120/240 V delta service
2. Three-phase – four-wire 120/208 V wye service
3. Three-phase – four-wire 277/480 V wye service
4. Three-phase – four-wire 265/460 V wye service (obsolete)

Figure 10.18: Three-Phase, Four-Wire Services – Voltage Less than 250 V

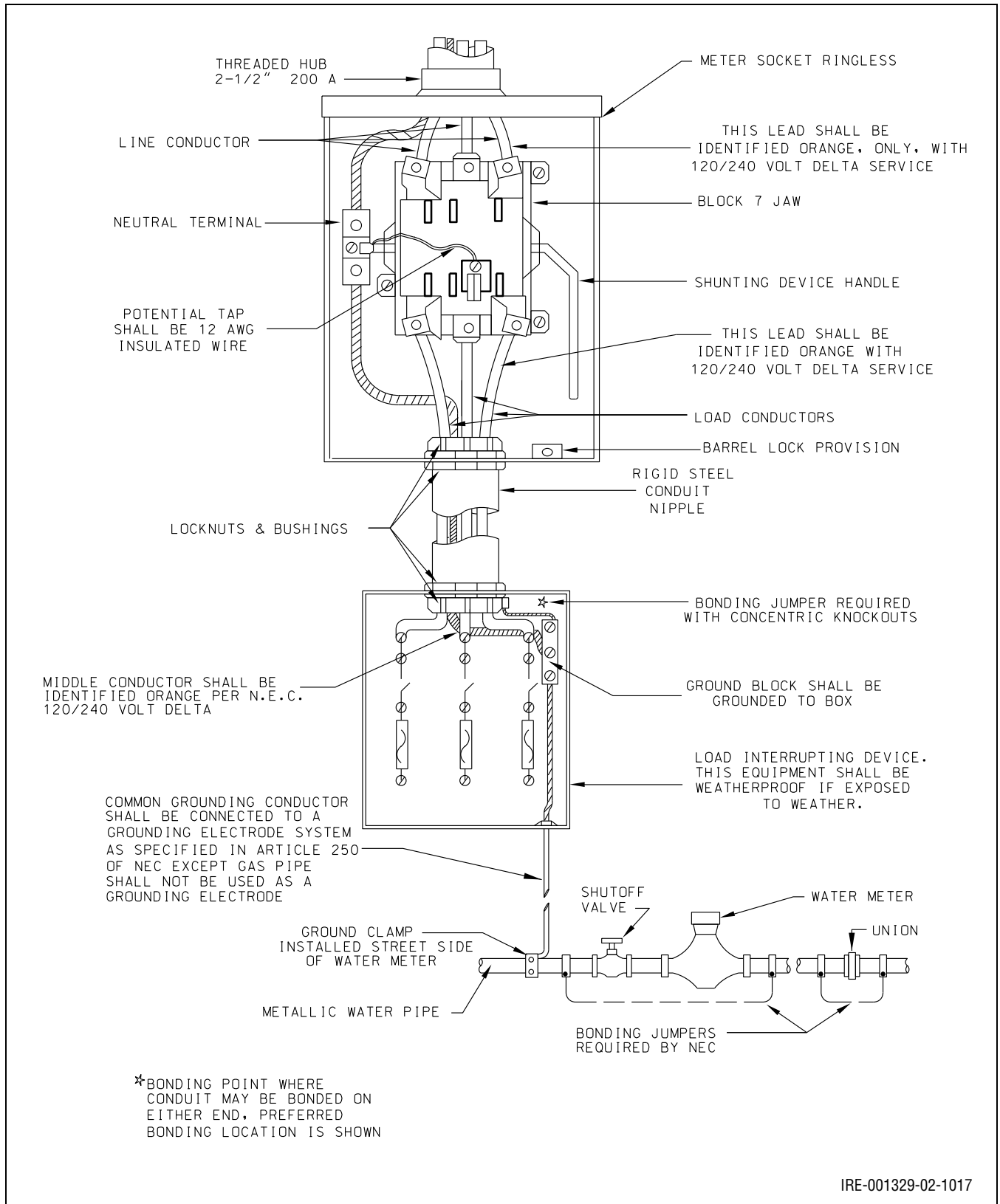

Figure 10.18 Notes:

PSE&G will:

1. Designate location of service equipment.
2. Furnish the meter socket, 200 A.
3. Furnish and install service drop conductors to the point of connection and install the meter.

Customer shall:

1. Furnish and install the service entrance equipment in accordance with the requirements of the NEC and PSE&G.
2. Use an approved oxide inhibiting compound on aluminum conductors.
3. Obtain an electrical inspection certificate from a recognized electrical inspection authority.
4. Meter pan must have a bypass horn, fifth jaw, and barrel lock provisions.
5. 120/240 V delta service shall be identified orange only.

Figure 10.19: Three-Phase Four-Wire Services, Voltages Greater than 250 V (Cold Sequence)

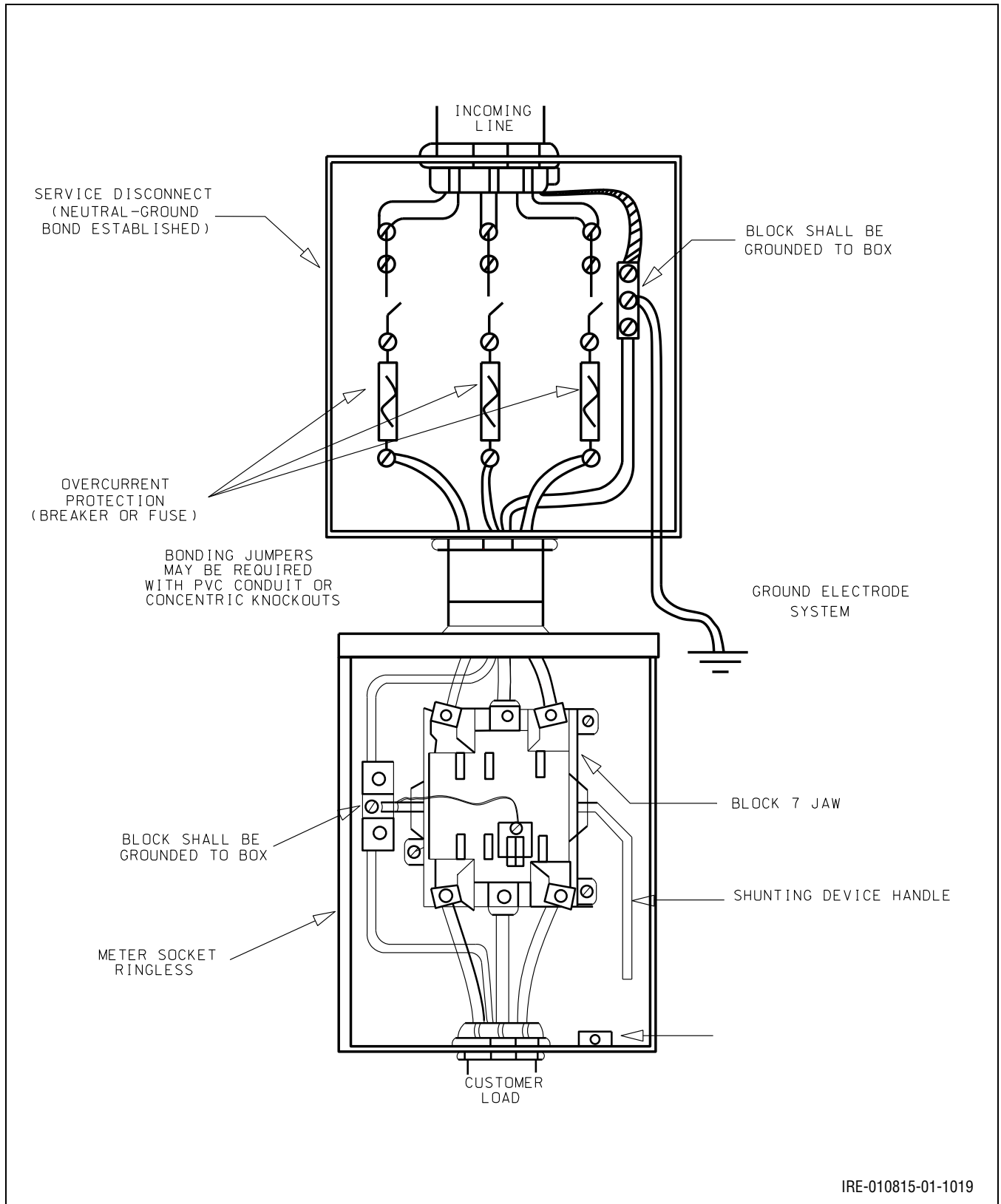

IRE-010815-01-1019

15 Grounding and Bonding

Figure 10.20: 120/208 or 120/240 V Service

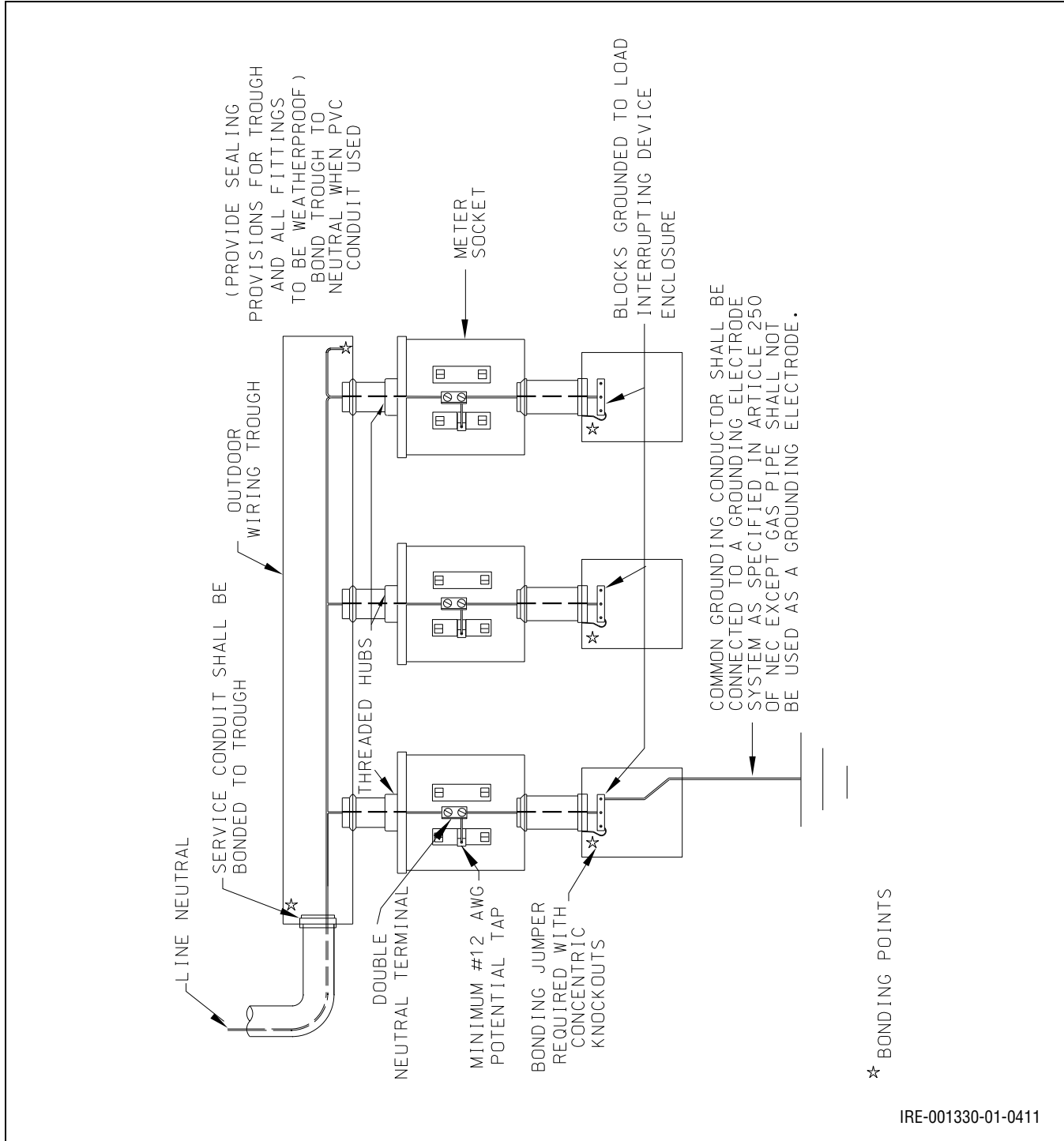

Figure 10.20 Notes:

Metered and unmetered conductors shall not occupy the same trough.

Figure 10.21: Trough with Multiple Enclosures, 120/208 or 120/240 V Service – Main Interrupting Device Before Meters

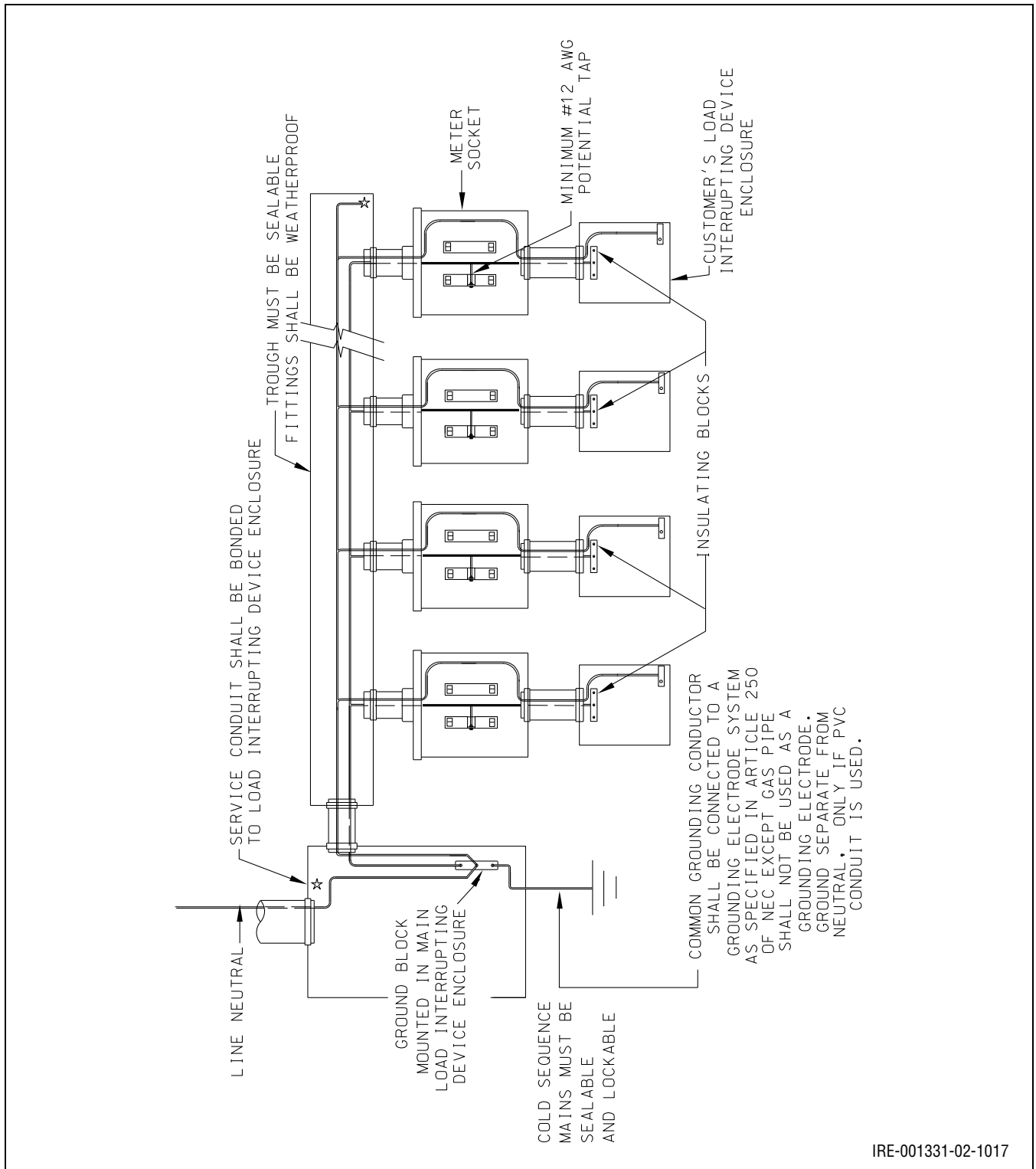

Figure 10.21 Notes:

Metered and unmetered conductors shall not occupy the same trough.

Figure 10.23: Combination Power and Light (4 W Delta Service)

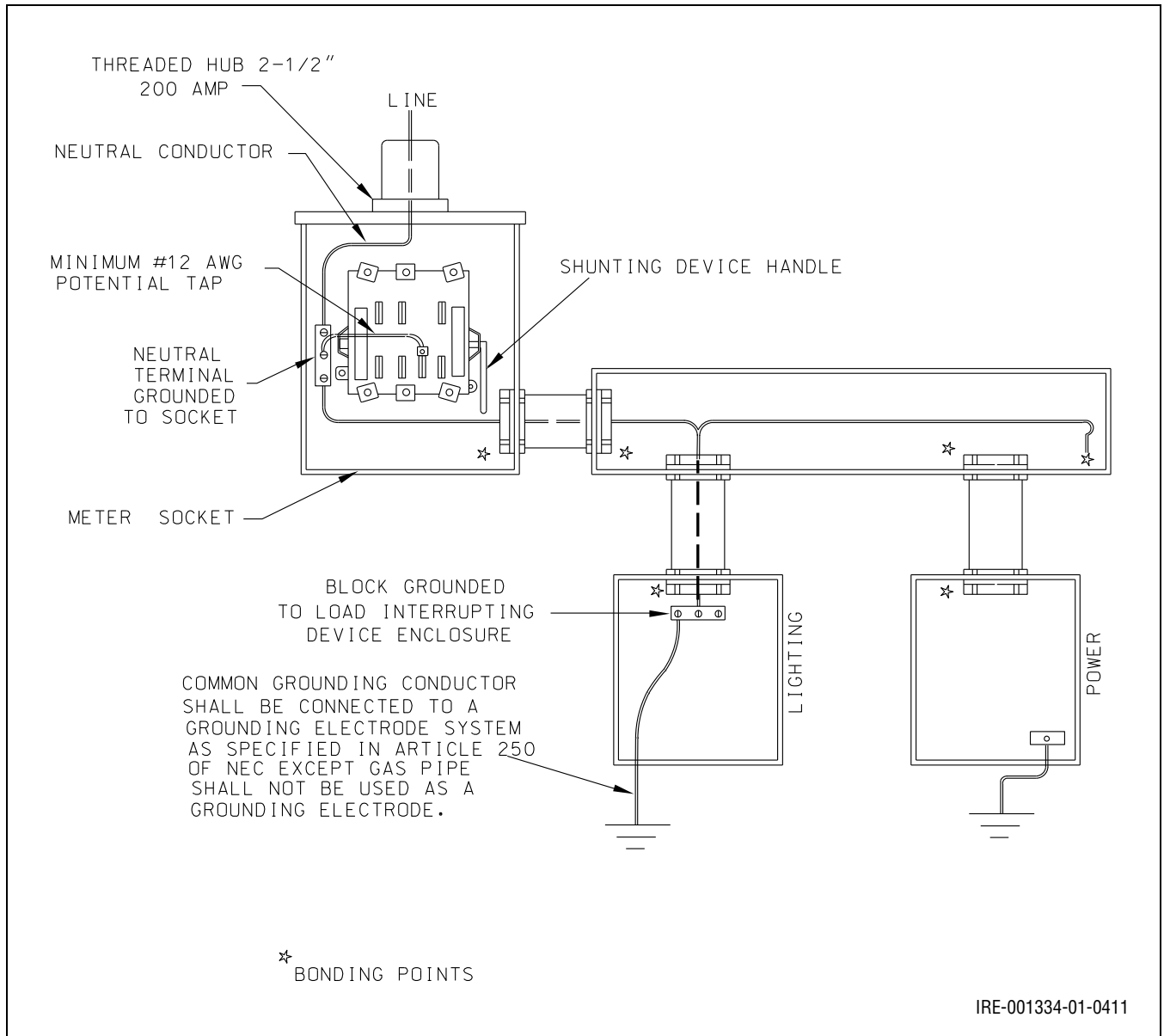

Figure 10.24: Grounding and Bonding CT Enclosure – Hot Sequence, Bar Type CT

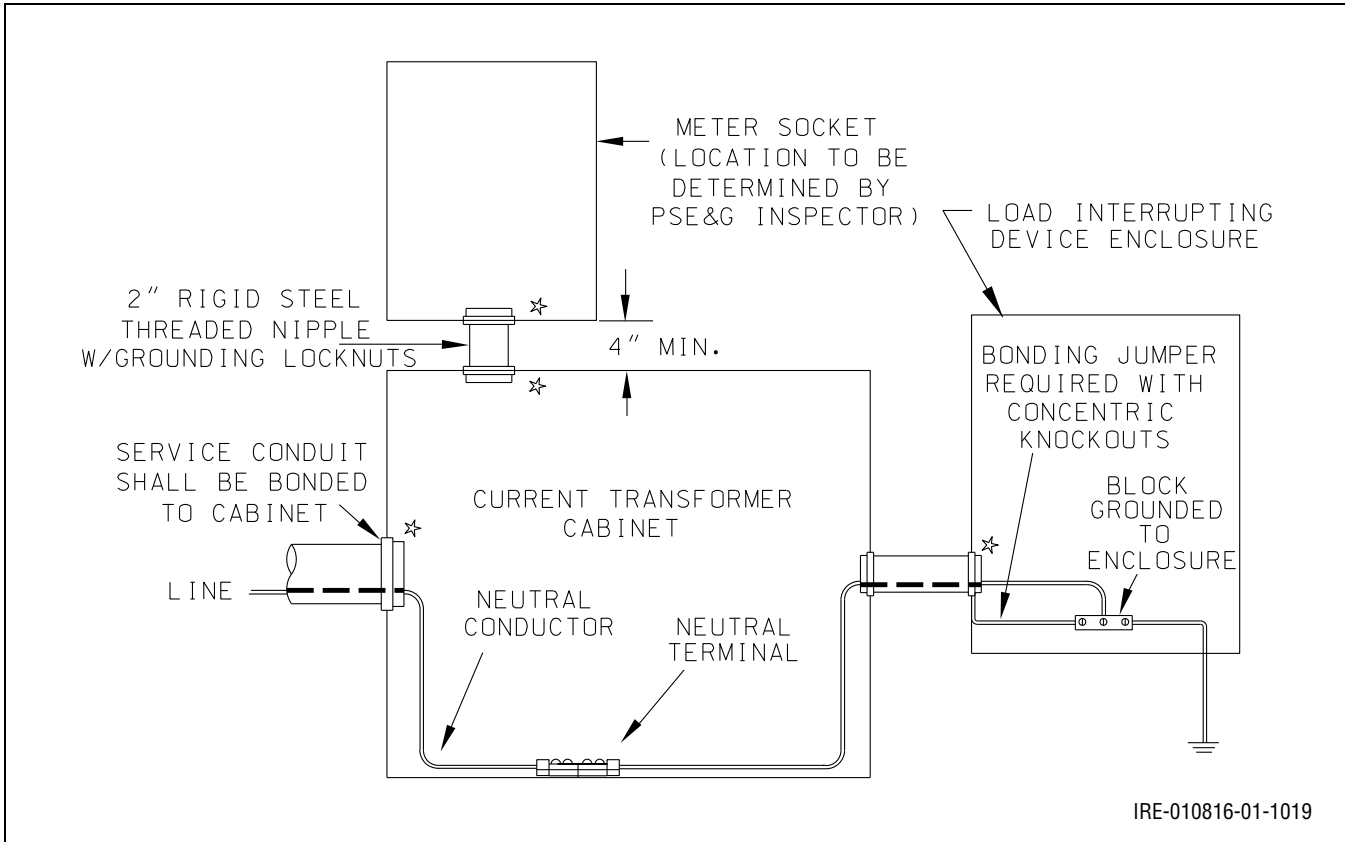

Figure 10.24 Notes:

For load interrupting devices on the load side of the Current Transformer (**CT**) cabinet, the neutral terminal shall be solidly bonded to the CT cabinet.

Figure 10.25: Grounding and Bonding CT Enclosure – Cold Sequence Bar Type CT

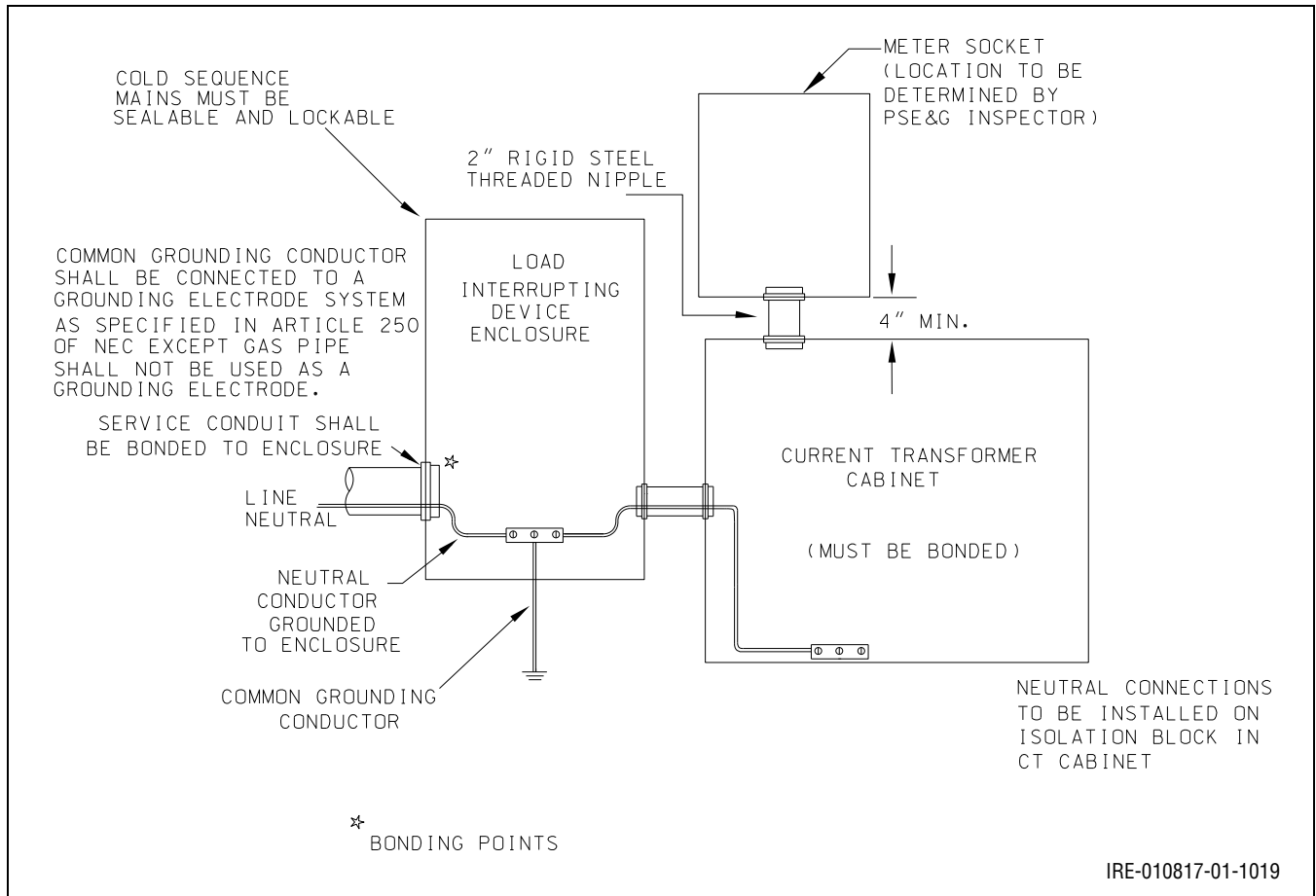

Figure 10.25 Notes:

For load interrupting devices on the line (grid) side of the CT cabinet, and if the CT cabinet is immediately adjacent to the interrupting device, then the neutral terminal shall be bonded to the current transformer cabinet, in other cases the neutral terminal shall be isolated from the CT enclosure (Immediately adjacent concept refers to NEC250.145(B) Exception no. 2 (2), other constraints may exist.)

- handle, and shall open to the right and left sides when the cabinet is mounted. No vertical support bars shall be placed behind the doors.
4. A one piece cover, where provided, shall be attached to the cabinet with tabs fastened to the cover and entering the top of the cabinet. Split hinges are not permissible with a one piece cover.
 5. Cabinets are to be furnished with twelve 1/2 in. x 2 in. bolts and hex nuts, and 24 Belleville washers and 24 flat washers. A minimum of 3 threads, maximum of 1/2 in., shall extend through the hex nut. All hardware shall be non-magnetic stainless steel.
 6. The cabinet shall meet all applicable requirements of the latest edition of the NEC, and shall be listed by a nationally recognized testing laboratory.

Figure 10.27: Window Type >801 A Secondary

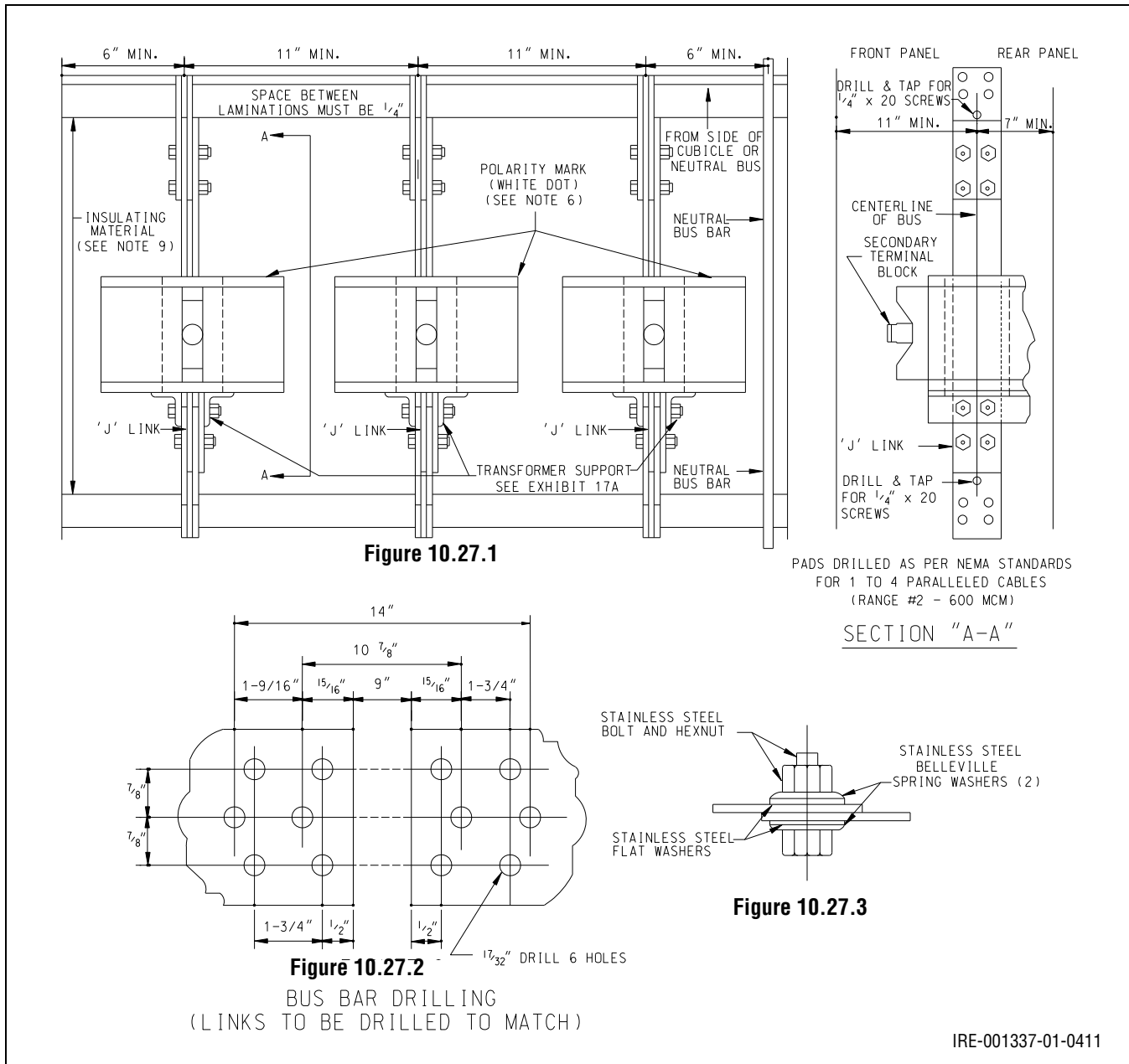

Figure 10.27 Notes:

1. Connecting, "J" links, terminals and hardware shall be furnished by the customer.
2. "J" Links are to be fabricated as follows:
 - Made of the same material as the bus bars.
 - Drilled as shown in Figure 10.27.2.
 - Have a maximum width of 5 in.

3. Bus supports shall be designed so that the bus will remain in position when the connecting links “J” are removed.
4. All bolted connections to the bus shall be bolted as shown in [Figure 10.27.3](#) using non-magnetic stainless 1/2 in. steel bolts, nuts, flatwashers and Belleville washers (17/32 in. I.D. - 1 3/8 in. O.D. tensile strength 5000 lb.). They are to be tightened until the Belleville washers are flattened, then loosened 1/12th of a turn. The bus shall be drilled to NEMA standards for 1 to 4 paralleled cables (line and load).
5. Aluminum bus shall be joined as follows:
 - When the areas of contact have been plated, be careful to not abrade or scratch the plating. Bolt together as shown in [Figure 10.27.3](#).
 - When the areas of contact have not been plated, brush the contact areas with a stiff fine wire brush until they are smooth and clean. Apply a liberal coat of oxide inhibiting compound. Wire brush again through the compound to remove the compound as shown in [Figure 10.27.3](#). After joined, do not wipe away the compound that has been forced out of the joint.
6. Transformers are oriented for services entering from the top. If service comes in from the bottom, the Current Transformers (**CT**) are to be set with the polarity marks at the bottom.
7. The neutral bus shall be in the same cabinet as the metering transformers and may be located on either side or in the front of the cabinet, and shall be drilled and tapped for 1/4 in. x 20 in. screws.
8. The neutral shall be electrically isolated from the cabinet. A removable bonding conductor shall be included for use whenever cabinet is to be bonded to the neutral.
9. Bus supports of insulating material shall be designed to securely support the bus, terminals, cables, current transformers, etc. under normal or fault conditions.
10. The cabinet shall be made from #12 gauge steel, and equipped with a pair of hinged doors.
11. The doors shall open to the right and to the left. They shall be hinged with split hinges that allow the doors to be removed when opened more than 45 degrees. The doors shall be equipped with a three point latch. No vertical support bars shall be behind the doors.
12. The cabinet shall have PSE&G approved barrel locking provisions, and shall be sealable and have pad locking provisions.
13. The cabinet shall meet all applicable requirements of the latest edition of the NEC, and shall be listed by an NRTL such as Underwriter’s Laboratories.
14. A drawing (including dimensions) of the cabinet shall be submitted to PSE&G for review. A letter notifying the customer of an accepted review will be sent by the local Electric Distribution Wiring Inspection office.

17 Secondary Service Equipment with Bar Type Current Transformers (CTs)

Figure 10.28: Maximum Capacity Parallel 500 kcmil Conductors – Three-Wire Services Single-Phase or Three-Phase

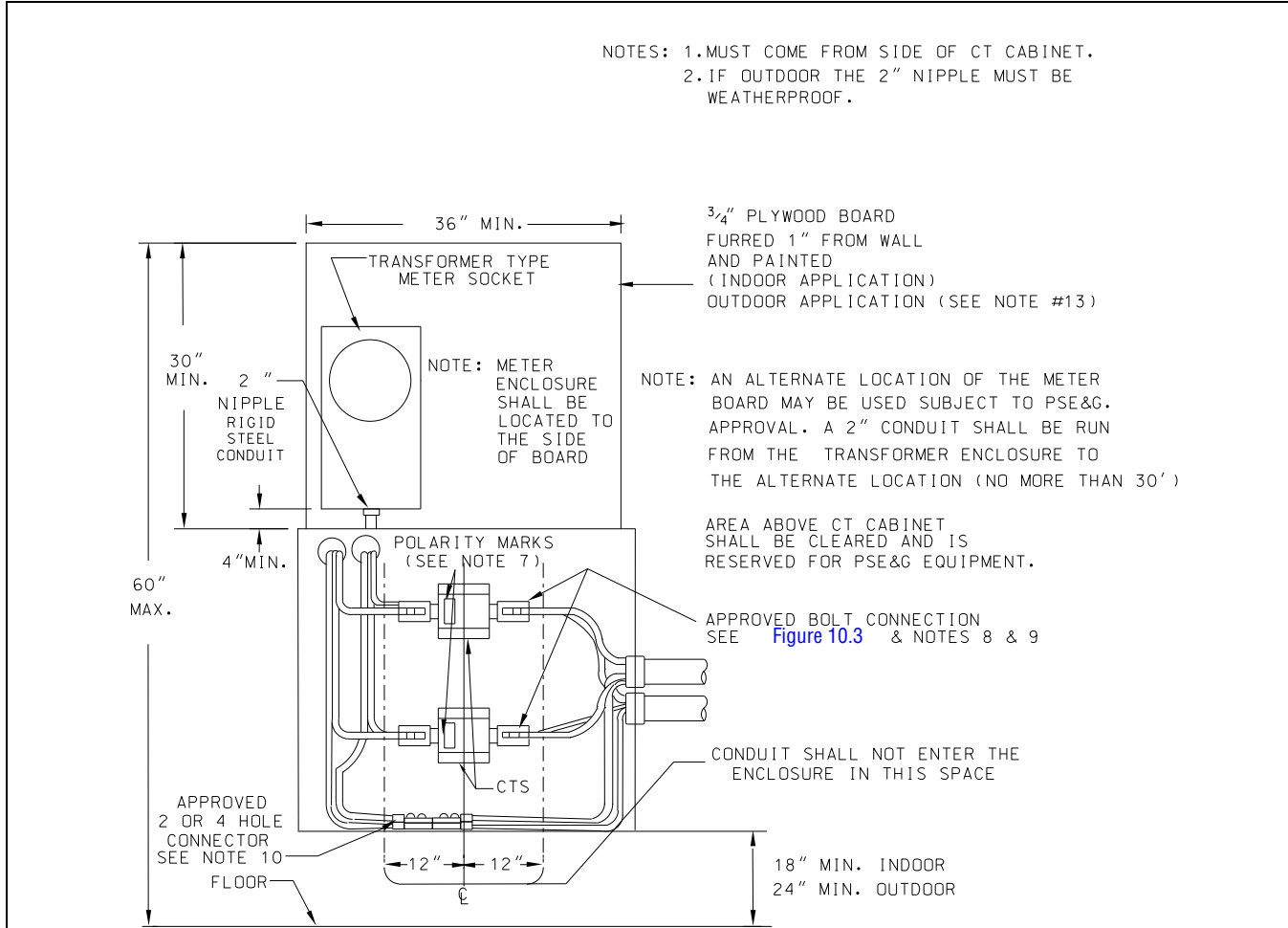

Figure 10.28.1

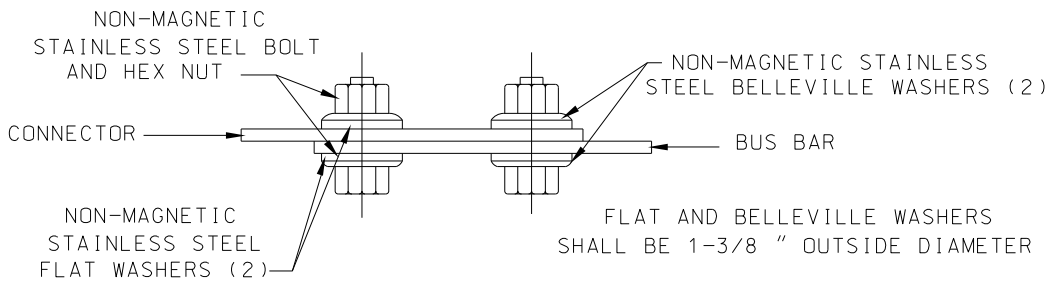

Figure 10.28.2

IRE-001338-02-1017

Figure 10.28 Notes:

PSE&G will:

1. Designate the location of the service installation.
2. Furnish the meter socket and two CTs for three-wire service.
3. Furnish and install the meters and metering control cable.

Customer shall:

1. Furnish and install the meter board and install the meter socket.
2. Furnish and install an NRTL listed CT enclosure. See [Figure 10.26](#) for details.
3. Furnish and install the service entrance equipment in accordance with the requirements of the NEC and PSE&G.
4. Install CTs on the mounting studs of the CT enclosure with the primary polarity marks facing the incoming line.
5. Furnish and install approved double hole connectors with 9/16 in. holes for connecting the conductors in accordance with [Section 21.1.2](#) Note 2.
6. Install the terminal connections using 8 - 1/2 in. x 2 in. bolts and hex nuts, with 16 Belleville washers and 16 flat washers. All such hardware shall be furnished by the customer, and shall be made from non-magnetic stainless steel. (See [Figure 10.28.2](#) for typical termination details.) Bolts on neutral connection must be installed with thread on inside cabinet.
7. Furnish and install an NRTL listed connector, and bond it to the CT enclosure, when applicable.
8. Make an appropriate provision in the enclosure for PSE&G to terminate its control wire neutral conductor, and include a #8 AWG lug for that purpose. Contact the local PSE&G Wiring Inspection department for further details.
9. Obtain required approvals of inspection authorities having jurisdiction.
10. Install CT cabinet 18 in. minimum from floor to bottom of cabinet (indoor) or 24 in. minimum from finished grade to bottom of cabinet (outdoor). If installed outdoor, all service equipment must be mounted on Versabar/Unistrut.
11. Install CT cabinet 60 in. maximum from grade level to top of CT cabinet.
12. Keep area above CT cabinet clear as it is reserved for PSE&G metering and equipment.

Figure 10.29: Maximum Capacity Parallel 500 kcmil Conductors – Three-Phase Four- Wire Service

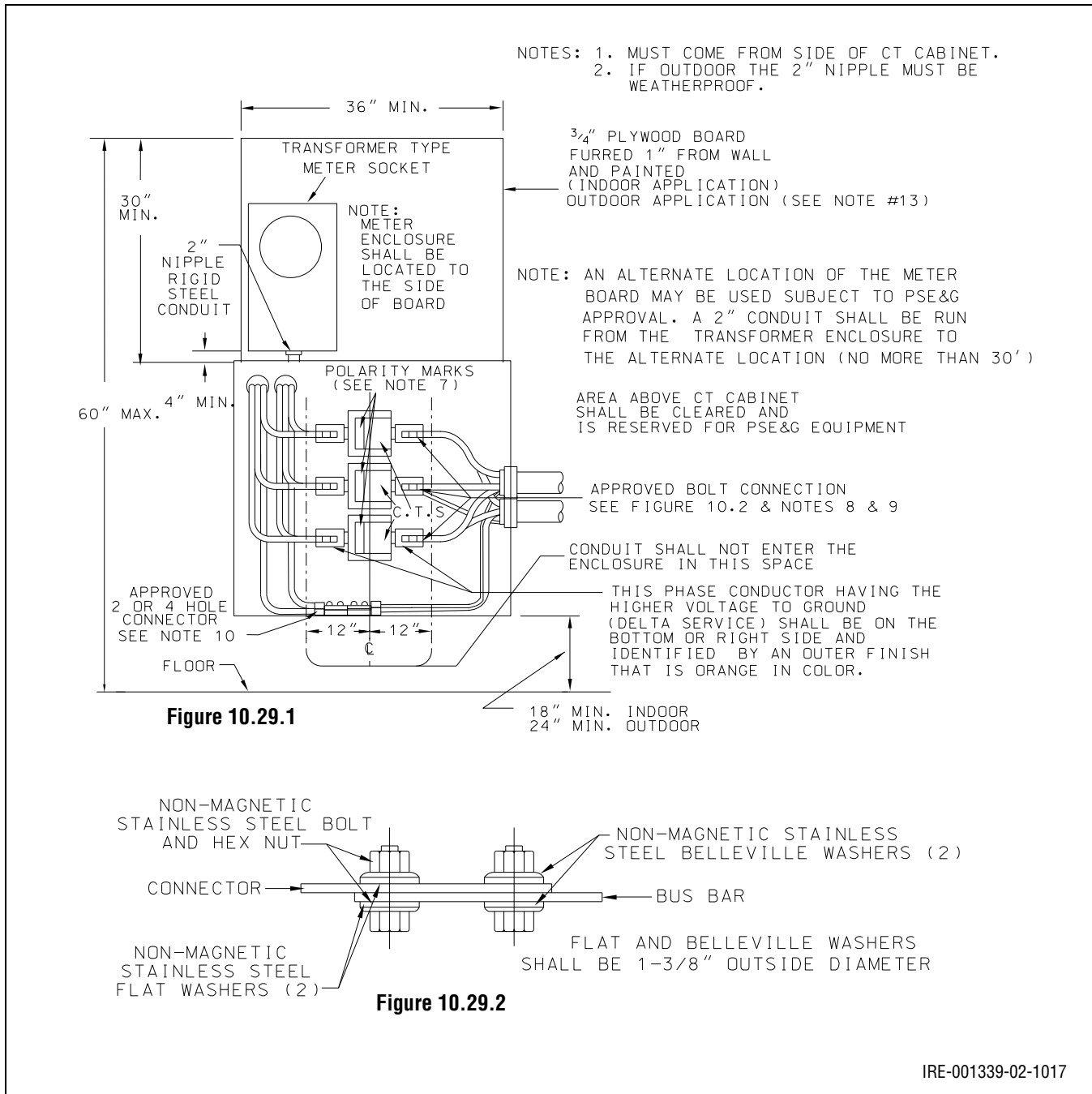

Figure 10.29 Notes:

PSE&G will:

1. Designate the location of the service and meter installation.
2. Furnish the meter socket and three CTs for four-wire service.
3. Furnish and install the meters and metering control cable.

Customer shall:

1. Furnish and install the meter board and install the meter socket.
2. Furnish and install an NRTL listed CT enclosure. See [Figure 10.26](#) for details.
3. Furnish and install the service entrance equipment in accordance with the requirements of the NEC and PSE&G.
4. Install CTs on the mounting studs of the CT enclosure with the primary polarity marks facing the incoming line.
5. Furnish and install approved double hole connectors with 9/16 in. holes for connecting the conductors in accordance with [Section 21.1.2](#) Note 2.
6. Install the terminal connectors using 12 - 1/2 in. x 2 in. bolts and hex nuts, with 24 Belleville washers and 24 flat washers. All such hardware shall be furnished by the customer, and shall be made from non-magnetic stainless steel. (See [Figure 10.29.2](#) for typical installation details.) Bolts on neutral connection must be installed with thread on inside cabinet.
7. Furnish and install an NRTL listed connector and bond it to the CT enclosure, when applicable.
8. Make an appropriate provision in the enclosure for PSE&G to terminate its control wire neutral conductor, and include a #8 AWG lug for that purpose. Contact the local PSE&G Wiring Inspection department for further details.
9. Obtain required approvals of inspection authorities having jurisdiction.
10. Install CT cabinet 18 in. min. from floor to bottom of cabinet (indoor) or 24 in. min. from finished grade to bottom of cabinet (outdoor). If installed outdoor, all service equipment must be mounted on Versabar/Unistrut.
11. Install CT cabinet 60 in. max. from grade level to top of CT cabinet.
12. Keep area above CT cabinet clear as it is reserved for PSE&G metering and equipment.

18 Minimum Clearances and Bus Arrangement for Bar Type Current Transformers 200 to 800 A Secondary/Switchgear

Figure 10.30: Minimum Clearances and Bus Arrangement for Bar Type Current Transformers 200 to 800 A Secondary

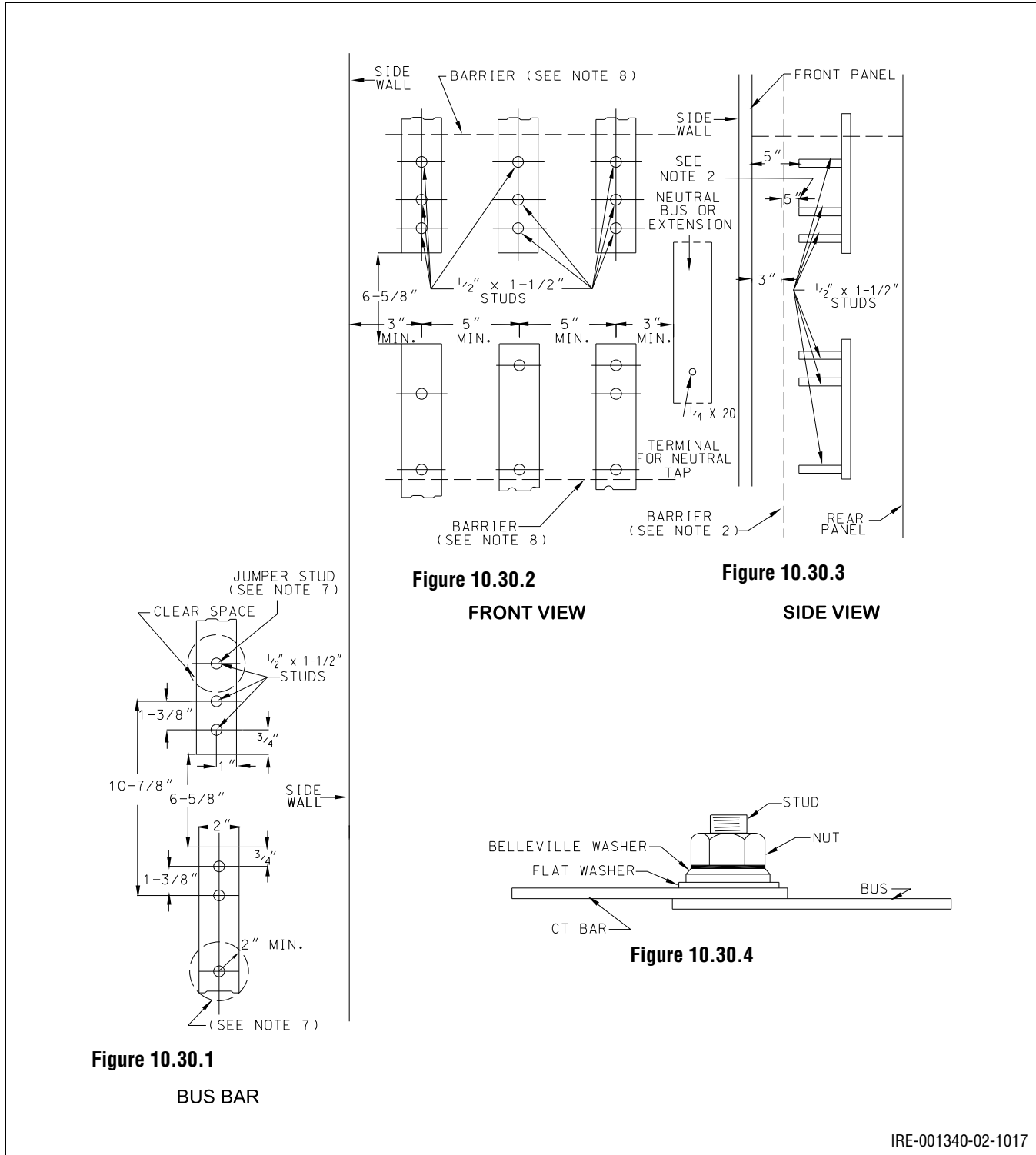

IRE-001340-02-1017

Figure 10.30 Notes:

1. The bus shall provide full support for the current transformers.
2. Whenever metering transformers are mounted behind the meter mounting panel, an additional 3 in. of space shall be provided, and a grounded dead front barrier or a barrier of insulating material shall be installed.
3. The customer shall furnish six 1/2 in. non-magnetic stainless steel studs, nuts, flat washers, and Belleville washers for each metering transformer position.
4. All grounding shall be in accordance with current edition of the NEC.
5. Aluminum bus shall be joined as follows:
 - When the areas of contact have been plated, be careful not to abrade or scratch the plating. Bolt together as shown in [Figure 10.31.3](#).
 - When the areas of contact have not been plated, brush the contact areas with a stiff fine, wire brush until they are smooth and clean. Apply a liberal coat of oxide-inhibiting compound. Wire brush again through the compound to remove the oxide film. Without removing the compound, bolt the two surfaces together using lubricated bolts as shown in [Figure 10.31.3](#). Do not wipe away the excess compound that has been forced out of the joint.
6. The neutral bus shall be in the same cubicle as the metering transformers, and located on either side of the front of the cubicle, and shall be drilled and tapped for accepting 1/4 x 20 in. screws.
7. Studs shall be provided for jumper leads for shunting from the line side to load side when changing current transformers under load. Studs are shown in an optional location, and may be positioned elsewhere provided they are surrounded by a clear area of 2 in. min. radius, and are in a convenient position for connection of jumpers.
8. The customer shall furnish and install an insulated barrier between the current transformer and customer's equipment, if such equipment is located above or below the transformers.
9. For indoor installation, the meter mounting panel shall be 3/4 in. plywood, a minimum size of 36 in. x 30 in., painted black, and mounted 1 in. off the wall. There shall be a minimum of 12 in. of space above the meter panel to the top of the board for PSE&G's use. If installed outdoors, all service equipment must be mounted on Versabar/Unistrut.

19 Mounting Dimensions for Current Transformers in Cubicle – Window Type >801 A to 4000 A Secondary/Switchgear

Figure 10.31: Mounting Dimensions for Current Transformers in Cubicle – Window Type >801 A to 4000 A Secondary

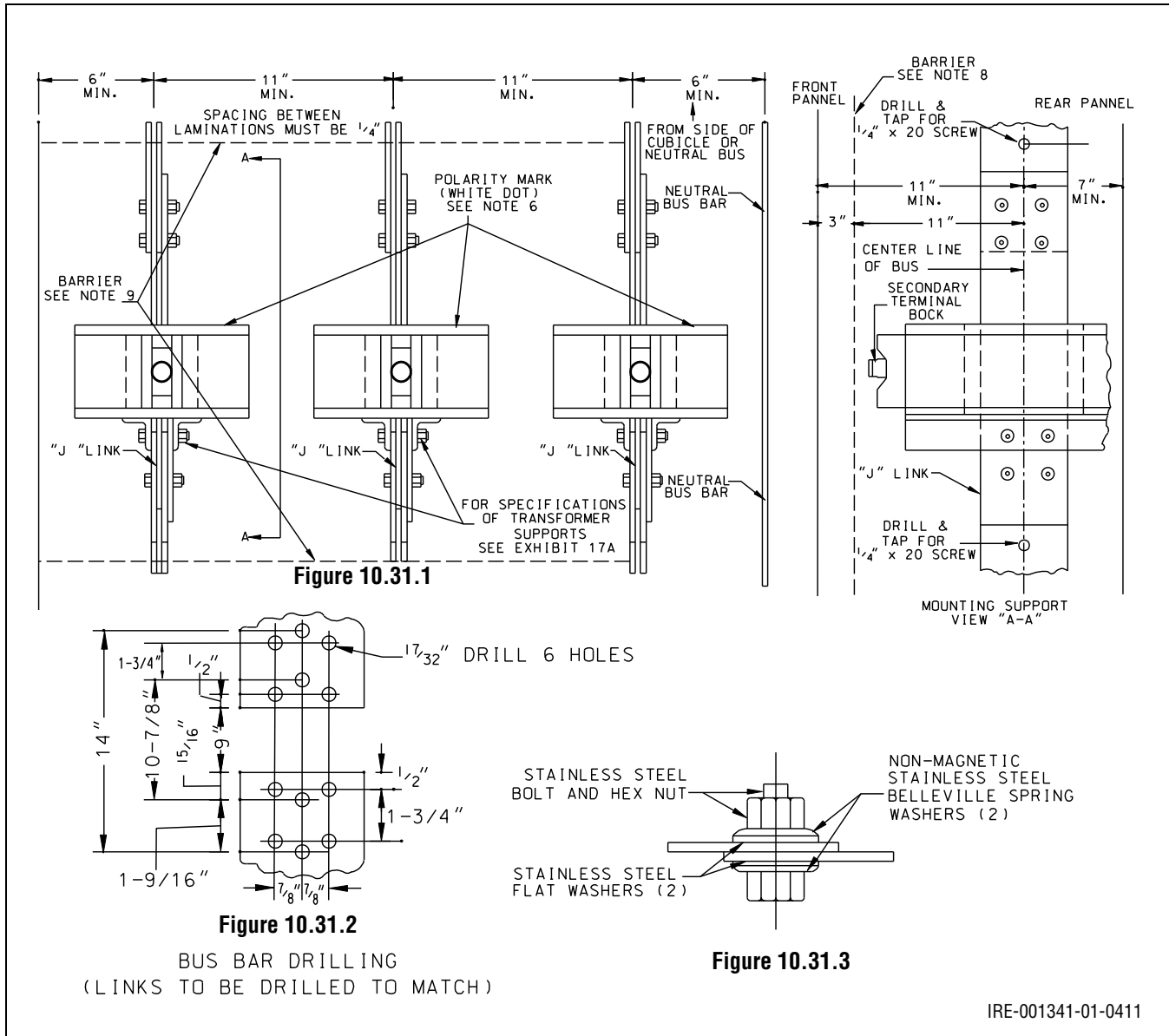

Figure 10.31 Notes:

1. The connecting "J" links and transformer supports shall be furnished by the customer.
2. "J" links are to be fabricated as follows and shall:
 - Be made from the same material as the bus
 - Be drilled as shown in [Figure 10.31.2](#)
 - Have a maximum width of 5 in.

3. Bus supports shall be designed such that the bus will remain in position when the connecting links “J” are removed.
4. The customer shall supply eight 1/2 in. bolts and nuts, 16 flat washers and sixteen Belleville washers (17/32 in. ID - 1-3/8 in. OD tensile strength 5000 lb.) for each phase for both copper and aluminum bus connections. Nuts, bolts, flat washers and Belleville washers shall be made of non-magnetic stainless steel. Bolts shall be long enough that they extend through the nuts, and several threads shall be visible upon completion of the connection. A minimum of 3 threads, maximum of 1/2 in.
5. Aluminum bus shall be joined as follows:
 - When the areas of contact have been plated, be careful not to abrade or scratch the plating. Bolt together as shown in [Figure 10.31.3](#).
 - When the areas of contact have not been plated, brush the contact areas with a stiff, fine wire brush until they are smooth and clean. Apply a liberal coat of oxide-inhibiting compound. Wire brush again through the compound to remove the oxide film. Without removing the compound, bolt the two surfaces together using lubricated bolts as shown in [Figure 10.31.3](#). Do not wipe away the excess compound that has been forced out of the joint.
6. The current transformers are oriented for accepting the incoming service (“Line Side”) from the top of the cubicle. If the service (“Line Side”) is to be supplied from the bottom of the cubicle, the current transformers shall be set with their polarity marks at the bottom.
7. The neutral bus shall be in the same cubicle as the metering transformers, and located on either side of the front of the cubicle, and shall be drilled and tapped for accepting 1/4 x 20 in. screws.
8. Whenever metering transformers are mounted behind the meter mounting panel, an additional 3 in. of space shall be provided. A removable grounded dead-front barrier, or a barrier of insulating material, shall be installed.
9. An appropriate barrier shall be furnished and installed by the customer where the customer’s equipment is located above or below the CT area in the same cubicle. The barrier shall safely separate the CT area and the customer’s equipment.
10. For indoor installation, the meter mounting panel shall be 3/4 in. plywood, a minimum size of 36 in. x 30 in., painted black, and mounted 1 in. off the wall. There shall be a minimum of 12 in. of space above the meter panel to the top of the board for PSE&G’s use. If installed outdoors, all service equipment must be mounted on Versabar/Unistrut.

20 Current Transformer Mounting Bracket Specifications and Dimensions

Figure 10.32: Current Transformer Mounting Bracket Specifications and Dimensions

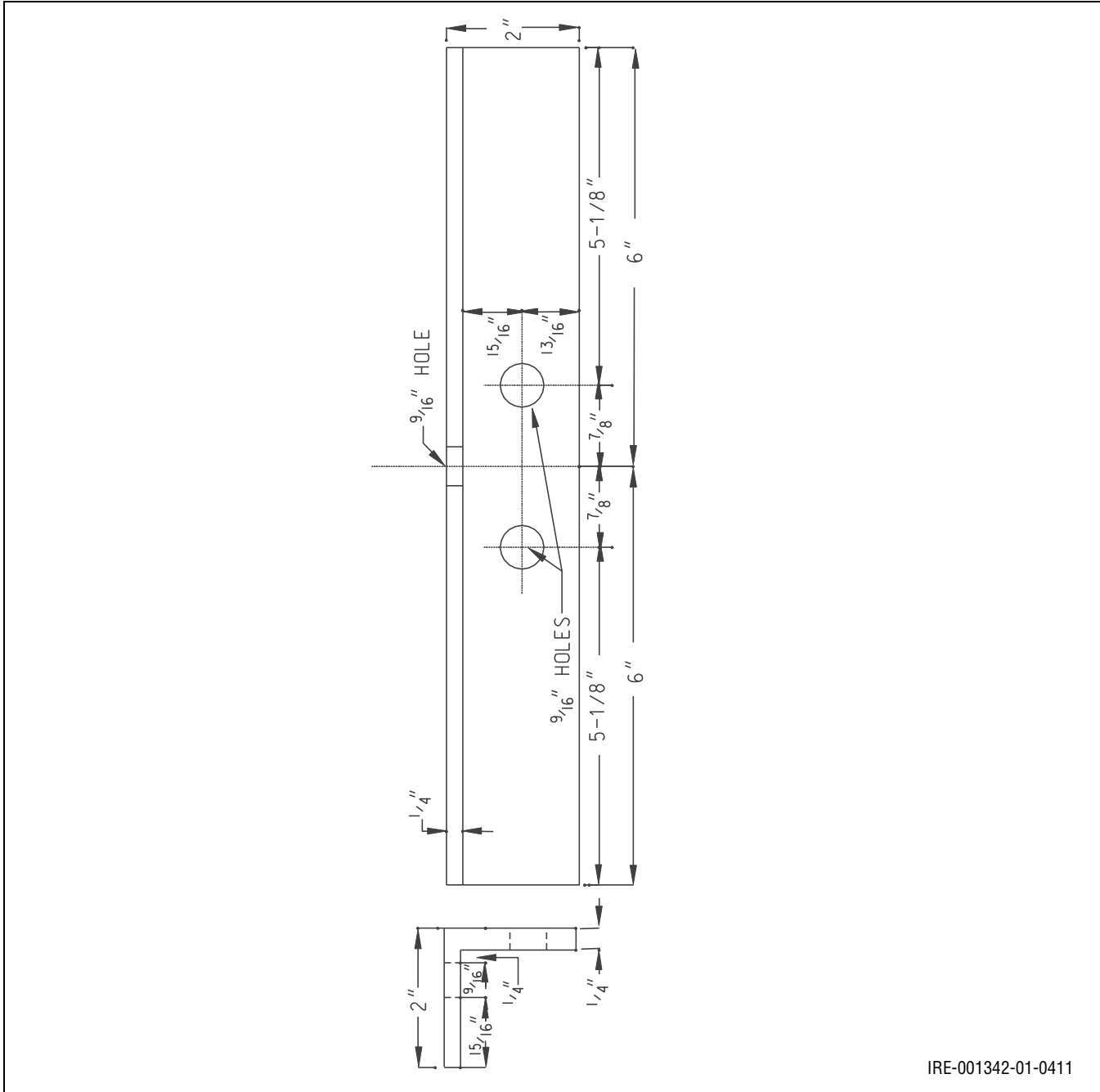

IRE-001342-01-0411

Figure 10.32 Notes:

1. The bracket shall be fabricated from a material suitable for safely supporting a 25 lb. current transformer when mounted as shown in [Figure 10.31](#).
2. The 9/16 in. hole in the top of each bracket is for inserting a plastic tie strap to secure the current transformer to the bracket.

21 Service Runs

21.1 Secondary Connections to Terminals of PSE&G Equipment

21.1.1 General Instructions

Please note the following general instructions for secondary connections to terminals of PSE&G equipment.

1. Transformer mat installations – all work on the secondary side of the transformers, including the connections and connectors to the transformer terminals, will be done by and at the expense of the customer. All connections to transformer terminators must be covered with rubber and vinyl tape.
2. Padmounted transformer installations – the installation of the primary underground conduit or trenching for direct buried primary cable from the transformer pad to the selected PSE&G pole, and all work on the secondary side of the transformer including supplying the connectors and bolting them to the transformer terminals, will be done by and at the expense of the customer. See [Table 10-7](#) for number of cables per phase by cable size needed to handle full transformer capacity.
3. The customer is responsible for the CT installation.

21.1.2 Terminal Connectors

Please note the following requirements regarding terminal connectors.

1. Connectors shall be made of a material suitable for use with the conductor material of the cable or wire they will be terminating.
2. The terminal connector shall be drilled to NEMA standards for transformers, and shall have at least two holes for terminating one or two conductors, and for three or four conductors the connector shall have four holes. Connections to the transformer terminal shall be made with 1/2 in. bolts and nuts, flat washers and Belleville washers (17/32 in. ID, 1-3/8 in. OD, tensile strength 5000 lb) for both copper and aluminum bus connections. Nuts, bolts, flat washers and Belleville washers shall be made of non-magnetic stainless steel. Bolts shall be long enough that they extend through the nuts, and several threads shall be visible upon completion of the connection.
3. Only terminals and connectors specifically approved for use with aluminum are to be used with aluminum conductors, including those for grounding and bonding. Terminals and connectors listed by an NRTL for use with aluminum are marked with the symbol “CU-AL” or “AL”. The connections shall be prepared in accordance with [Figure 10.31](#), Note 5. The connector pads shall be tin or silver-plated.

Figure 10.33: Secondary Connections to Terminals of PSE&G Equipment

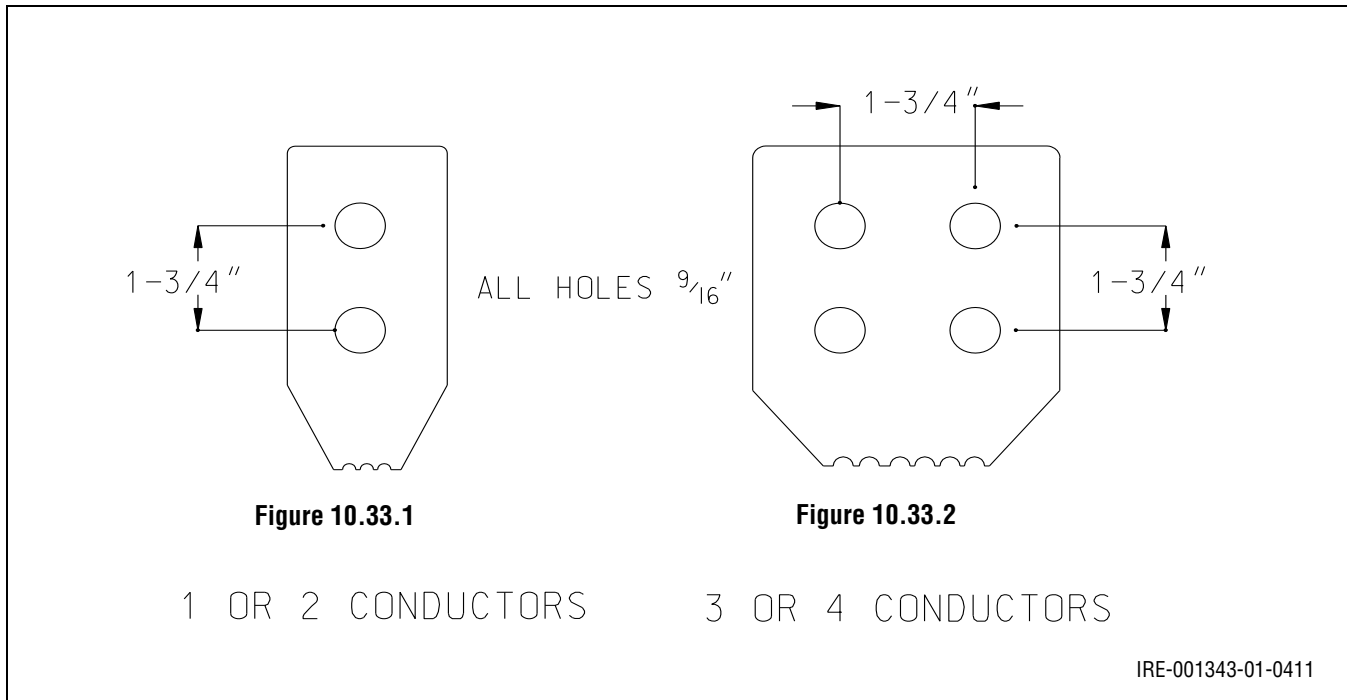

4. The secondary connections shall be inspected by PSE&G before being taped. The secondary mat connections shall be taped with ultraviolet resistant tape by the customer’s contractor before the installation is energized. Pad connections, and connections to the low voltage bar type current transformers, shall not be taped. Acceptable manufacturer’s catalog numbers of approved tapes are listed below. No other tape types shall be used, unless an alternative type is accepted by PSE&G prior to its use.

Table 10-5: Acceptable Manufacturer’s Catalog Numbers of Approved Tapes

Manufacturer	Catalog Number
Plymouth/Bishop Electric	L969
3M	130 C

21.1.3 Color Codes

For wire markings on Four Wire Delta connections, only the High Leg is marked with orange tape and the neutral with white tape (120/240 three-phase, four-wire). On 277/480 V and 120/208 three-phase, four-wire service installations. All phases shall be identified; orange tape shall only be used for 120/240 delta service. Red tape shall not be used. Only the neutral shall be marked with white tape. If parallel conductors are used, the contractor may color code the conductors to identify the phases. There shall be no Orange or Green color coding tape used on phase conductors. Orange color conductors or coding tape shall be strictly limited to identifying 120/240 three-phase, four-wire delta services as shown in [Section 24](#)

22 Fiberglass Pad – Present Design Single-Phase

Figure 10.34: Fiberglass Pad – Present Design Single-Phase

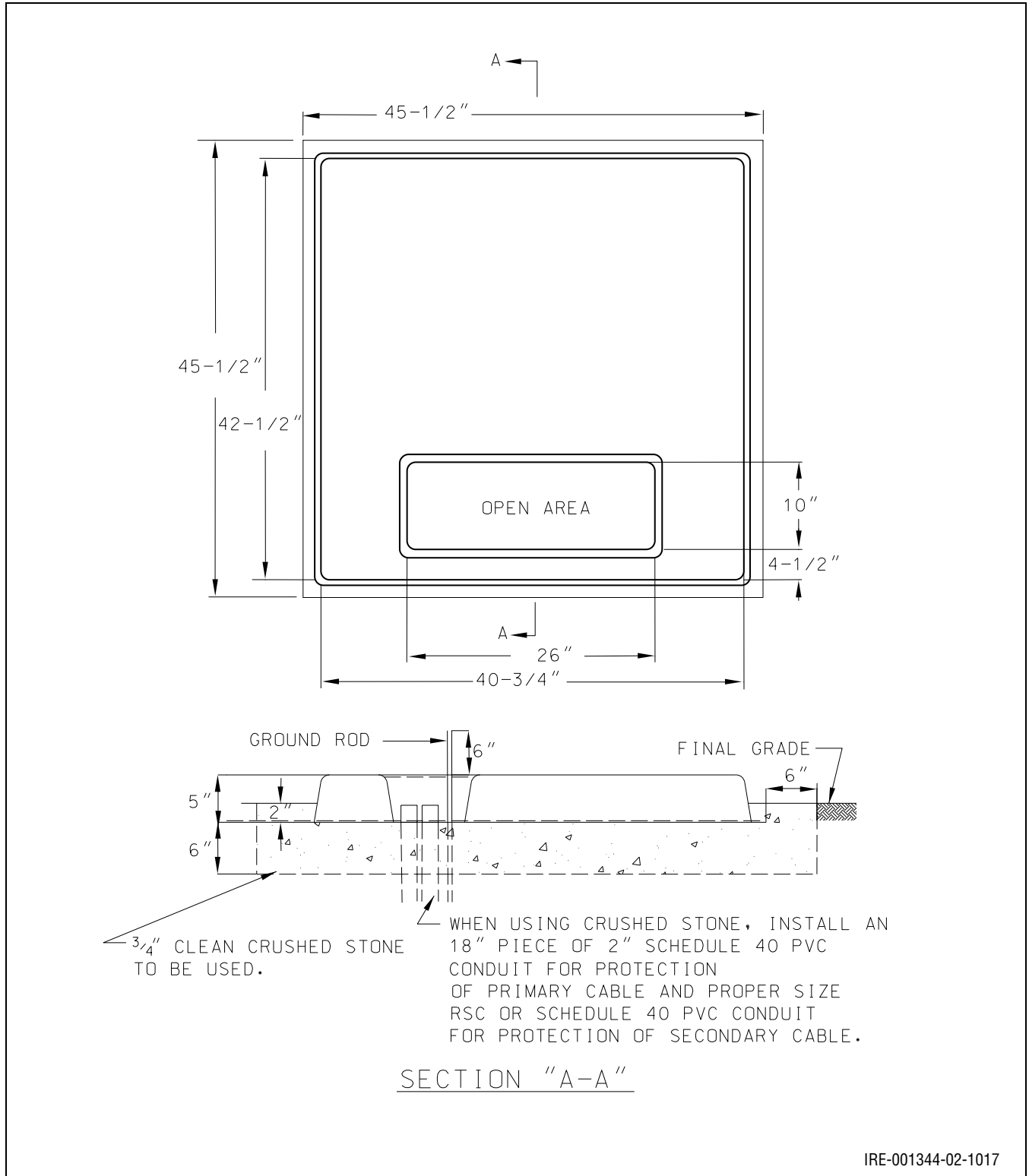

23 Secondary Conduit Connections for Single-Phase Open Delta Transformer

Figure 10.35: Secondary Conduit Connections for Single-Phase Open Delta Transformer

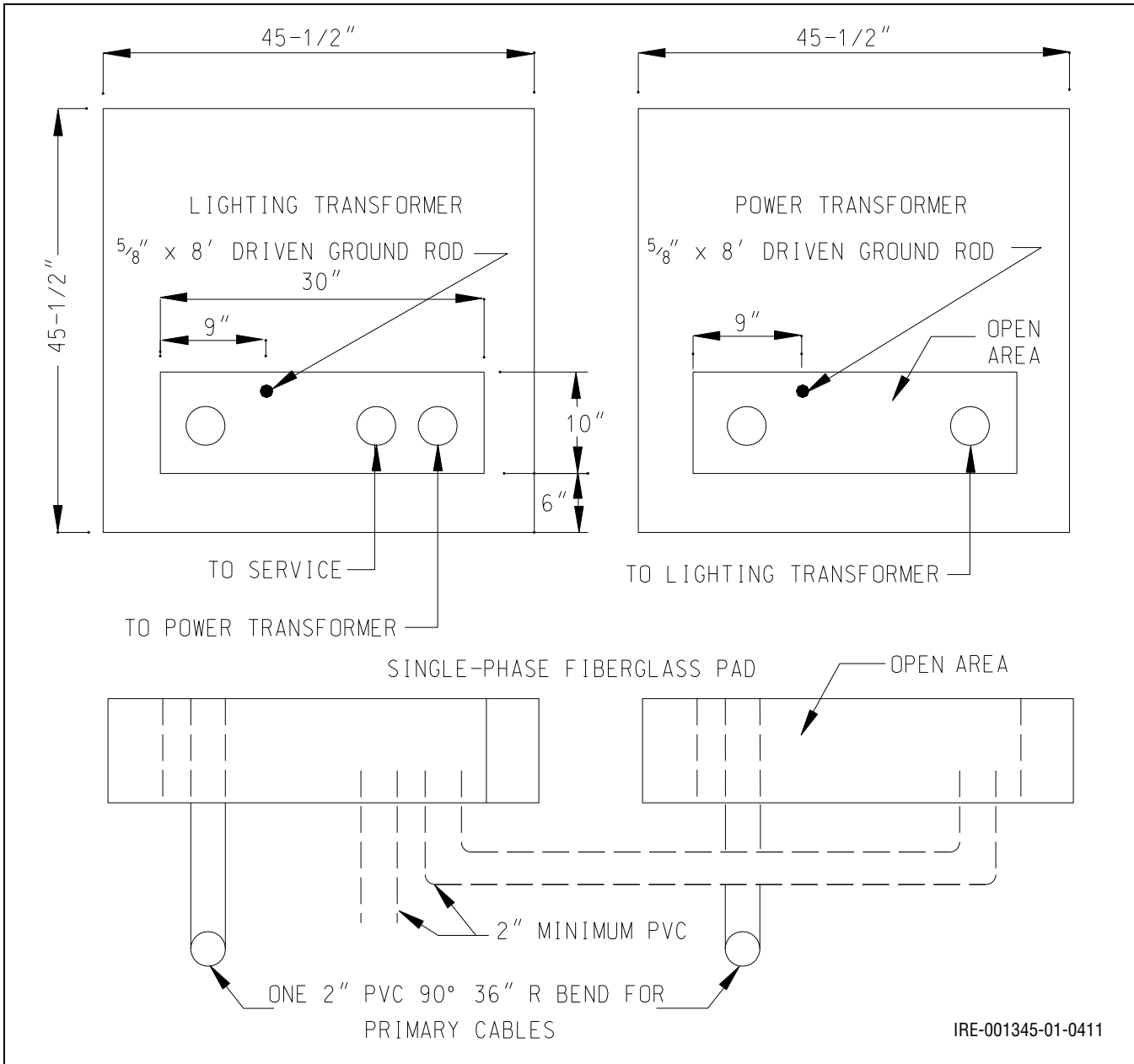

Figure 10.35 Notes:

1. Conduit to be installed and pad placed prior to primary cable installation by PSE&G.

24 Single-Phase Padmounted Transformer – Open Delta Connections

Figure 10.36: Single-Phase Padmounted Transformer – Open Delta Connections

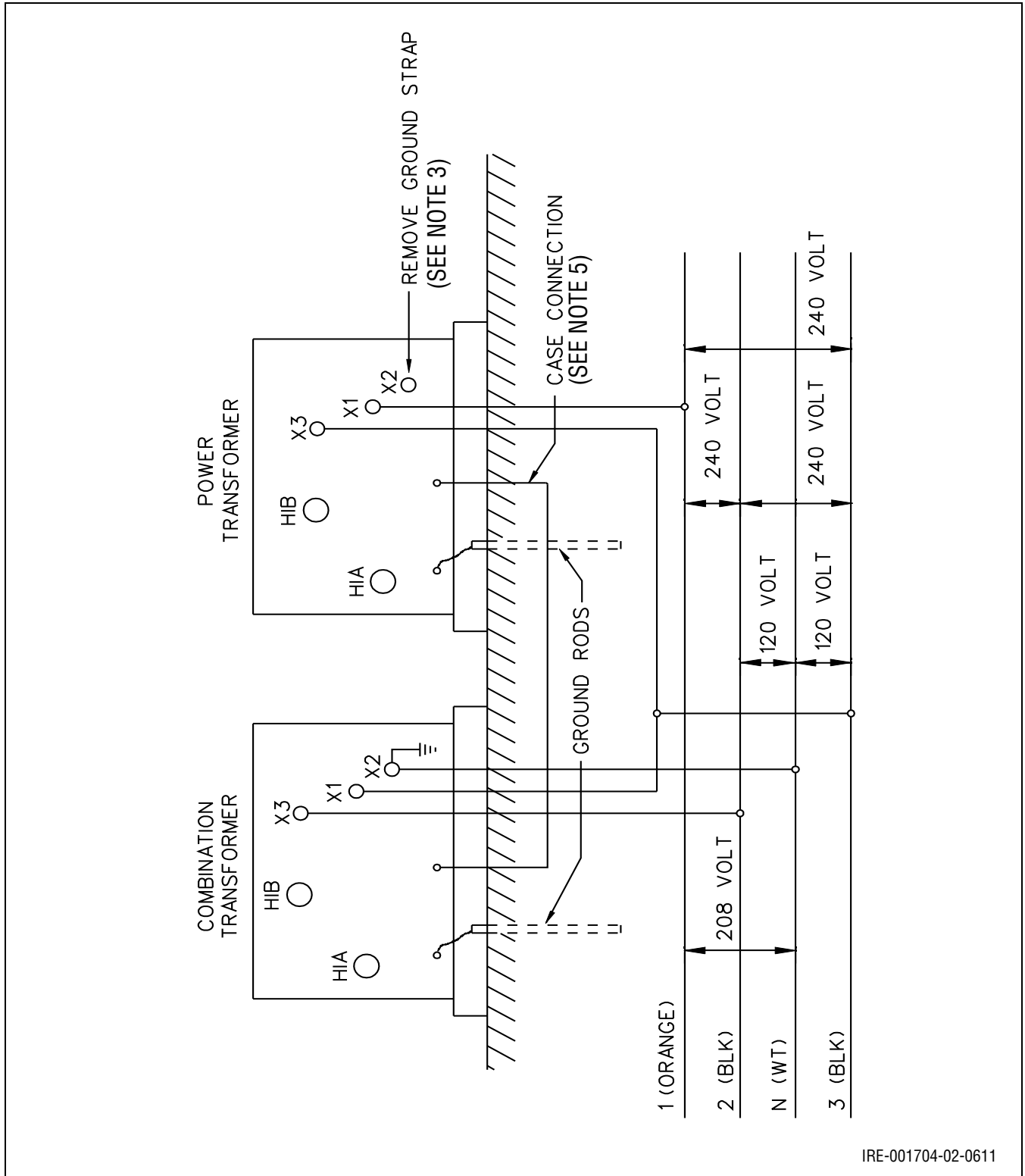

Figure 10.36 Notes:

General

1. Three-phase, open-wye (primary), open-delta (secondary) 120/240 V, four-wire connections shall be made as shown in [Figure 10.36](#).
2. The combination transformer shall be connected to the leading primary phase.
3. The low-voltage neutral grounding strap on the power transformer shall be removed.

Prior to Energizing.

1. The transformers should be tested with a TILT tester prior to energizing.
2. The transformer cases shall be connected together from the ground lug to ground lug by a #4 AWG copper wire. The wire can be placed in the installed conduit along with the X1 to X3 common or by direct burying at least 1 ft below grade.
3. All neutral and ground connections shall be completed before the transformers are energized.

25 Single-Phase Padmounted Transformer Pads

25.1 General

Fiberglass pads are to be used for all single-phase padmounted transformer installations, except where for engineering reasons concrete pads would be required. See Exhibits 19 and 19A.

Transformers shall not be secured to the fiberglass pad.

25.2 Location

The pad shall generally be located as shown below, and the following conditions shall apply:

1. 3/4 in. crushed stone shall be placed under and around the pads.
2. The grade shall slope away from the building toward the pad.
3. The pad shall be accessible for inspection, and for installing and replacing the transformer, including driving heavy equipment over to it without damage to the landscaping or the equipment. Access design must be approved by PSE&G.
4. There shall be at least 2 ft clearance from the pad to walkways and driveways. The minimum distance from the pad to building windows and doors must be 10 ft.

Figure 10.37: Single-Phase Padmounted Transformer Pads

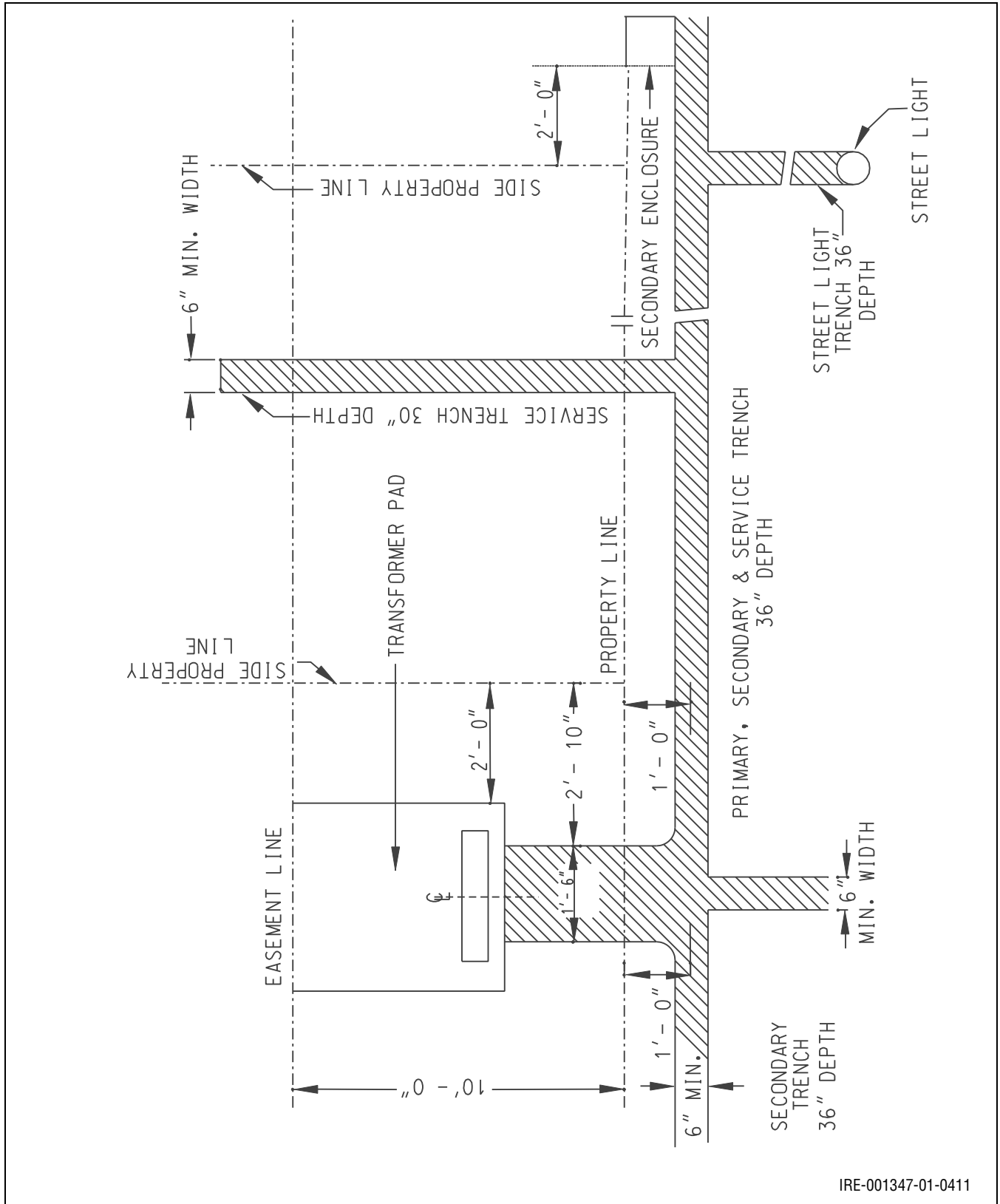

25.3 Front Lot Pad and Enclosure Details

If PSE&G determines that where the transformer pad is located might subject the transformer to damage by vehicles, the customer shall provide adequate bumper protection. The bumpers (bollards) and their location shall be approved by PSE&G and shall consist of 4 in. galvanized steel pipe filled with concrete, or equivalent, set in concrete. Bumpers shall have a minimum height of 4 ft above grade, a minimum depth of 3 ft below grade and set a minimum of 3 ft from the edge of the pad. In traffic areas where the bumpers might not be clearly seen at night, they shall be painted with a fluorescent paint, or marked with fluorescent tape suitable for outdoor use. The maximum distance between bumpers shall be 5 ft. Bumpers, when specified, must be placed before the transformer is energized.

25.4 Concrete Pad Construction Details

When concrete pads are used, precast, rather than poured in place pads, are preferred. The standard thickness of precast pads shall be 8 in. The standard thickness of poured in place pads shall be 12 in.

The following specifications refer to poured in place as well as precast pads.

1. Slump – 4 in.
28 Day Strength: 4000 lb./sq. in.
2. The ground where the pad is to be placed shall be properly prepared, tamped and levelled before installing the pad.
3. Portland cement shall be used and the cement shall be a standard brand, meeting all of the requirements of the American Society for Testing Materials (**ASTM**) C150 *Specification for Portland Cement*, and the ASTM tests for Portland cement, latest revisions.
4. Aggregates shall consist of inert materials that are clean, hard durable, free from any organic matter and uncoated with clay or dirt. Both large and small aggregates shall be well graded. All ASTM requirements for the specifications and tests for concrete aggregates, latest revisions, shall be observed.
5. The concrete shall be mixed until there is a uniform distribution of the materials and a uniform final mass in color and homogeneousness. Mixer shall be of such a type so as to assure maintaining correct proportions of the ingredients. If concrete is ready mixed, the requirements for the measuring of materials and for the mixing and delivery of the concrete shall meet those of the ASTM C94/C94M-04 *Standard Specification for Ready-Mixed Concrete*.
6. No concrete shall be poured in subfreezing weather unless authorized by PSE&G. When such authorization is obtained the concrete shall be fully protected against freezing until it is properly cured.

26 Three-Phase Padmounted Transformers

Figure 10.38: Three-Phase Padmounted Transformers

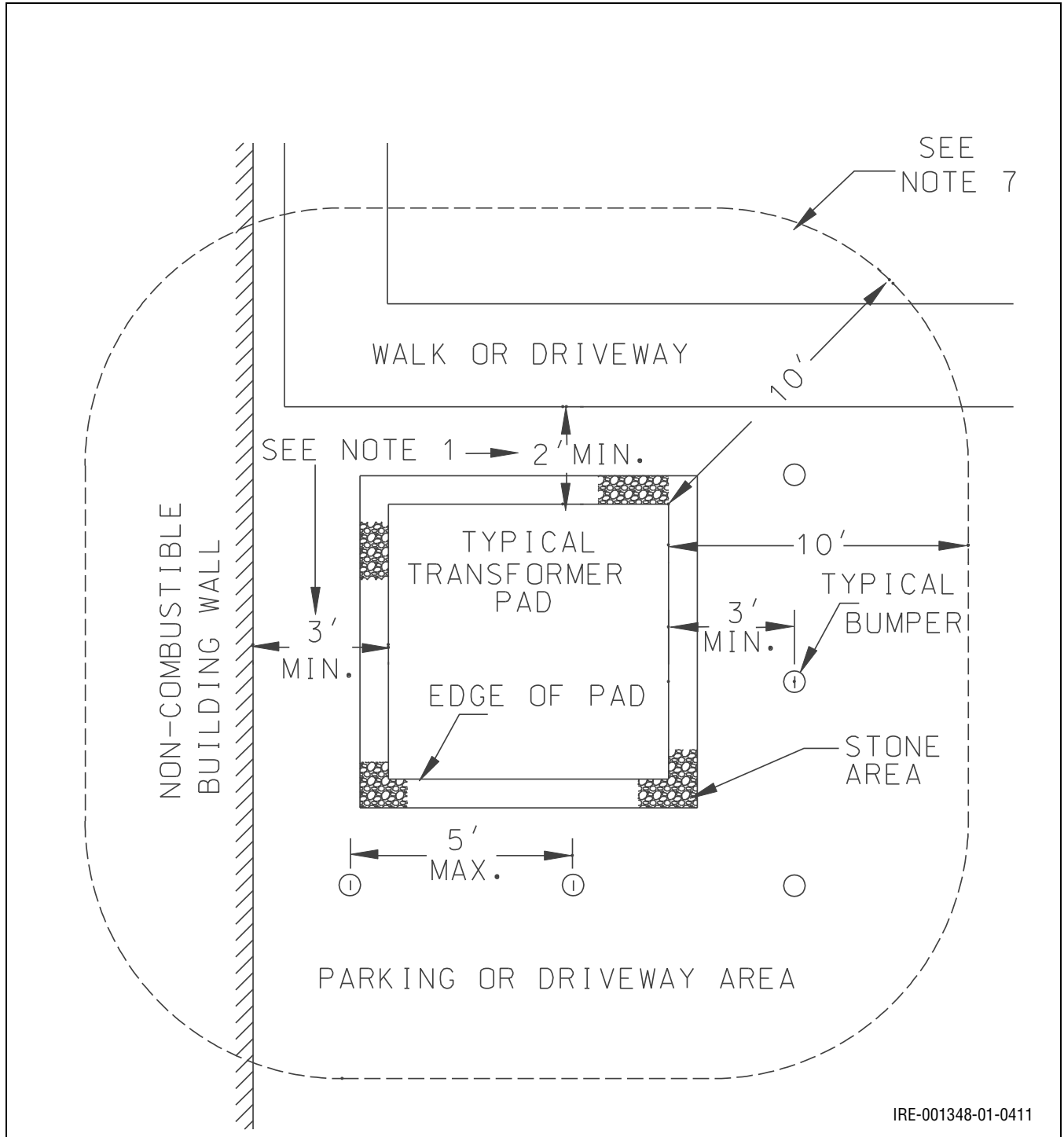

Figure 10.38 Notes:

1. All service entrance equipment and related construction involving PSE&G shall be installed according to the requirements of State and local authorities, PSE&G, and the current edition of the NEC.
2. In overhead zones where PSE&G and the customer have agreed that a secondary-metered, three-phase service shall be supplied from a padmounted transformer on the customer's property, PSE&G will install the pad, transformer and protective grounding for installations of 180 kVA demand and above. PSE&G will also install the primary cable, in accordance with the Tariff, and make all primary connections. The installation of the trench for direct buried cable or the primary underground conduits, depending on local conditions and as specified by the local Electric Distribution Division Office, from the transformer pad to the selected PSE&G pole, and all work on the secondary side of the transformer, including the connections to the transformer terminals, shall be done by and at the expense of the customer. If conduit is installed it shall extend no less than 2 in., or no more than 4 in., above final grade at the supply pole and it shall extend approximately 3 in. above the final level of the pad. PSE&G shall install the riser shield and back plate on the supply pole. Any primary circuit breaker or other device required by municipal code, but not by PSE&G, shall be installed by the customer at its expense.
3. Secondary service conductors of sufficient number and size (as shown in [Figure 10.8](#)) to carry the full capacity of the customer's service entrance installation shall be installed in underground conduit by the customer. Secondary conductors shall not be installed until the transformer has been set.
4. The land on which the pad is to be constructed shall be firmly compacted and established approximately at final grade. It shall be free of obstructions, unpaved and so located as to provide and maintain suitable and ready access to the pad for the delivery and removal of transformers and associated equipment. There shall be 10 ft of level and unobstructed land in front of the transformer's doors for PSE&G operational purposes. The customer shall grant to PSE&G an easement covering the location of the pad, the pole line or conduit run, and the access to the pad. Any non-standard pad elevation shall be reviewed by PSE&G prior to installation. The pad shall be accessible for inspection, and for installing and replacing the transformer, including driving heavy equipment over to it without damage to the landscaping or the equipment. Access design must be approved by PSE&G.
PSE&G Engineering shall be consulted regarding non-standard pad elevations in flood-prone areas.
5. If PSE&G determines that where the transformer pad is located might subject the transformer to damage by vehicles, the customer shall provide adequate bumper protection. The bumpers (bollards) and their location shall be approved by PSE&G and shall consist of 4 in. galvanized steel pipe filled with concrete, or equivalent, set in concrete. Bumpers shall have a minimum height of 4 ft above grade, a minimum depth of 3 ft below grade and set a minimum of 3 ft from the edge of the pad. In traffic areas where the bumpers might not be clearly seen at night, they shall be painted with a fluorescent paint, or marked with fluorescent tape suitable for outdoor use. The maximum distance between bumpers shall be 5 ft. Bumpers, when specified, must be placed before the transformer is energized.
6. Transformer pads shall be placed no less than 3 ft from non-combustible building walls, or 2 ft from adjacent walkways or driveways. If a pad is placed within 10 ft of a building it shall be oriented so that the doors of the transformer do not face the building.
7. Exit doorways, fire escapes or combustible materials located within a horizontal radius of 10 ft and within a height of 15 ft from any portion of a transformer pad, shall be protected by a fireproof barrier. Windows within the same area shall be protected by a fireproof barrier or permanently closed by masonry or fire resistant glass or glass block.
8. Transformer pads will be constructed in accordance with details and general specifications provided by PSE&G, and as described herein. Any deviations from standard PSE&G construction designs that are

- requested by the customer and approved by PSE&G, shall be made by the customer at the customer's expense with no cost allowance for any PSE&G supplied standard items that are changed or omitted.
9. Fiberglass pads may be used for all three-phase padmounted transformers rated 300 kVA and below, except where for PSE&G engineering reasons a concrete pad Type II-A, as shown in [Figure 10.40](#), is required.¹
 10. Concrete pads shall be used for three-phase padmounted transformers rated 500 kVA and above. Type III-A², as shown in [Figure 10.41](#), shall be used for a 500 to 2500 kVA transformer and Type V-A³, see [Figure 10.42](#), shall be used for two padmounted transformers with a total capacity of 3000 kVA.
 11. When precast concrete pads are used, check to insure that the transformer is level. If not, remove the transformer and pad and re-level the stones, and then reinstall the pad and transformer. Also, when precast pads are used, four "Swift Lift" anchor eyes are included for lifting the pad.
 12. For padmounted transformers located 150 ft or less from the curb line, the primary feed shall be underground from a PSE&G designated pole at the curb line to the pad. Underground primary feeds are recommended for longer runs if practicable, however, where the pad is located in excess of 150 ft from a pole at the curb line, an overhead feed will be acceptable on private property, provided the last horizontal 50 ft is run underground to the padmounted transformer.
 13. The area under and around the pad should be clear of all pipes such as sewer, water, natural gas or fuel oil, or any other facilities not connected with the electric service.
 14. Grading, seeding and landscaping in areas abutting a pad shall be the responsibility of the customer. Maintenance of access areas to the transformer pad is also the customer's responsibility. This requirement shall apply whether the installation is made prior to final grading or in an established lawn area.
 15. Where cables are to be installed by PSE&G, all customer-installed conduits shall contain an adequate pull line installed by the customer and firmly secured at both ends. This pull line shall be either 1/4 in. nylon, or 1/4 in. polypropylene rope.

Concrete Pad Construction Details

1. When concrete pads are used, precast when available, rather than poured in place pads, are preferred. The standard thickness of precast pads shall be 8 in. The standard thickness of poured in place pads shall be 12 in.
2. The following specifications refer to poured in place as well as precast pads.
 - Slump – 4 in.
28 Day Strength: 4000 lb/sq in.
 - The ground where the pad is to be placed shall be properly prepared, tamped and levelled before installing the pad.
 - Portland cement shall be used and the cement shall be a standard brand, meeting all of the requirements of the American Society for Testing Materials (**ASTM**) C150 *Specification for Portland Cement*, and the ASTM tests for Portland cement, latest revisions.

1. Limited to total maximum weight of 10,000 lb.
2. Limited to total maximum weight of 22,000 lb.
3. Limited to total maximum weight of 44,000 lb.

- Aggregates shall consist of inert materials that are clean, hard durable, free from any organic matter and uncoated with clay or dirt. Both large and small aggregates shall be well graded. All ASTM requirements for the specifications and tests for concrete aggregates, latest revisions, shall be observed.
- The concrete shall be mixed until there is a uniform distribution of the materials and a uniform final mass in color and homogeneousness. Mixer shall be of such a type so as to assure maintaining correct proportions of the ingredients. If concrete is ready mixed, the requirements for the measuring of materials and for the mixing and delivery of the concrete shall meet those of the ASTM C94/C94M-04 *Standard Specification for Ready-Mixed Concrete*.
- No concrete shall be poured in subfreezing weather unless authorized by PSE&G. When such authorization is obtained the concrete shall be fully protected against freezing until it is properly cured.

27 Fiberglass Pad Three-Phase Padmounted Transformers (300 kVA and Below) – Type II

27.1 General

Fiberglass pads may typically be used for all three-phase padmounted transformers rated 300 kVA and below, except where for PSE&G engineering reasons, a concrete pad is required. See the following drawings in this section.

27.2 Location

The pad shall generally be located and specified in accordance with [Figure 10.38](#).

27.3 Installation

See the pad construction details in for installation requirements.

Note



1. The primary conduit shall not extend more than 4 in. above the final level of the fiberglass pad. When primary cable is installed, a piece of 4 in. electrical grade PVC conduit shall be used to protect the primary cable from the crushed stone.
2. The secondary conduit must not extend more than 6 in. above the final level of the fiberglass pad. Secondary cable shall not be installed before the transformer is set.
3. A 2 in. x 12 in. pressure treated frame, staked to final grade, shall be installed in order to hold the stones in place, and when the surrounding earth is unstable or not brought up to the final grade. The frame shall be left in place and will provide a final grade reference.
4. The fiberglass pad shall be installed on a well tamped and levelled bed of clean 3/4 in. crushed stone approximately 14 in. in depth.
5. Customer shall install a 5/8 in. x 8 ft ground rod to obtain the required 25 ohms or less ground resistance. Add additional rods if necessary to achieve the 25 ohms resistance level.

Figure 10.39: Fiberglass Pad Three-Phase Padmounted Transformers (300 kVA and below) – Type II (Highline Current Design Type II Pad)

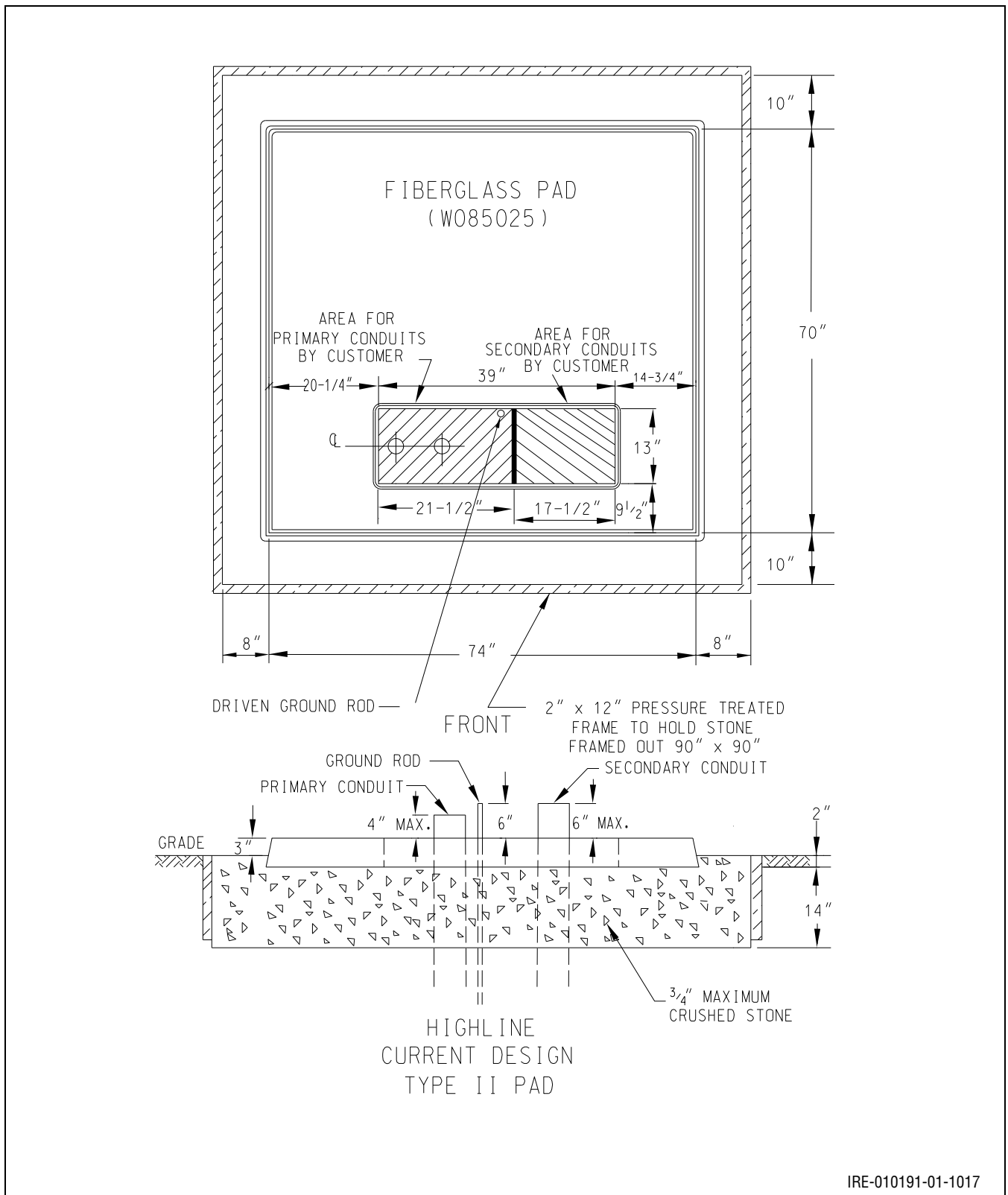

28 Pad Construction Detail

Figure 10.40: Three-Phase Padmounted Transformer – Type II-A (Concrete)

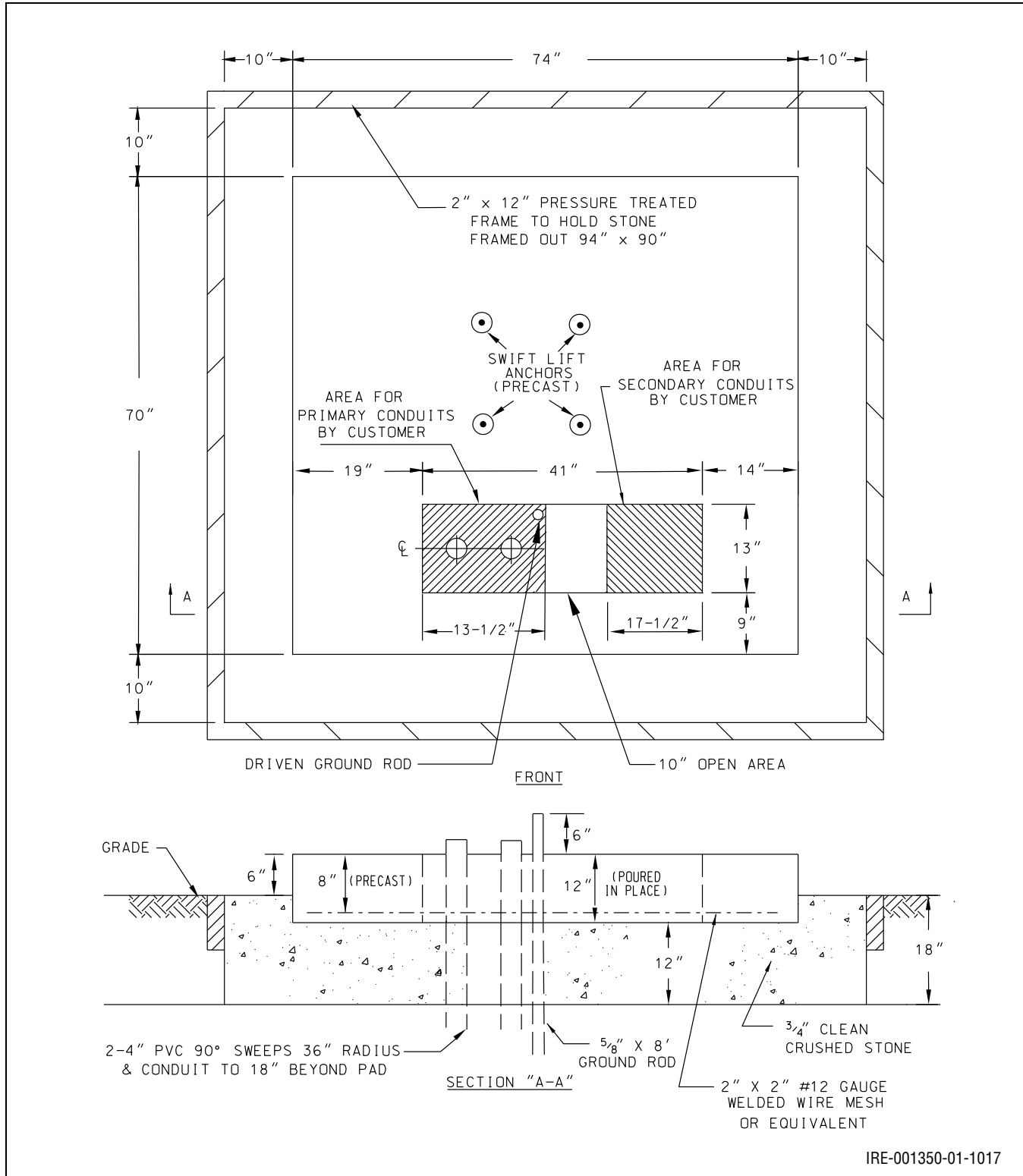

Figure 10.40 Notes:

1. The extension of the conduits above the surface of the pad shall be limited as follows:
 - Primary conduit 4 in. max.
 - Secondary conduit 6 in. max.
2. Mark grade on pipes.
3. Precast pads are 8 in. deep.
Poured in place pads are 12 in. deep.

Figure 10.41: Three-Phase Padmounted Transformer – Type III-A (Concrete)

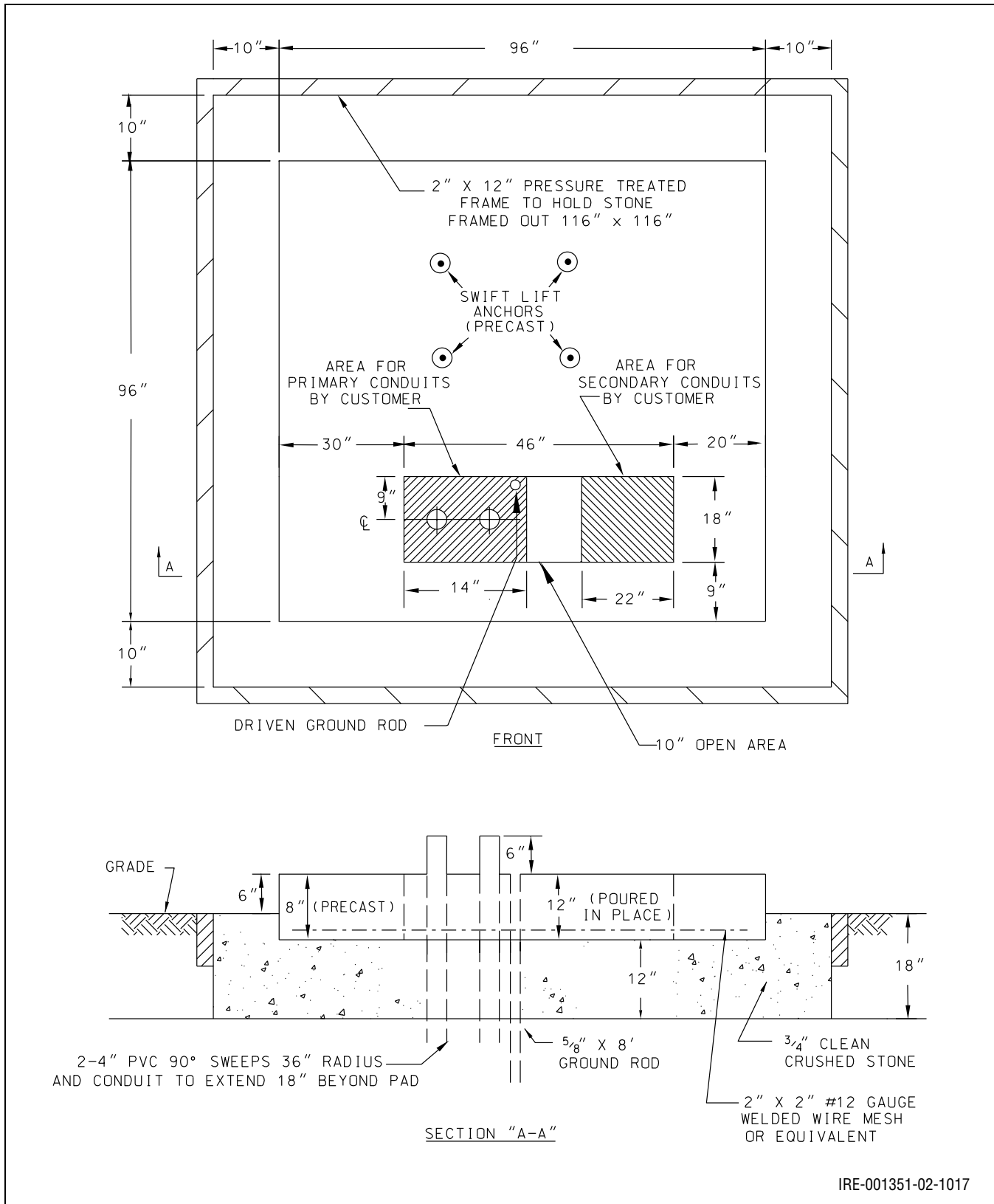
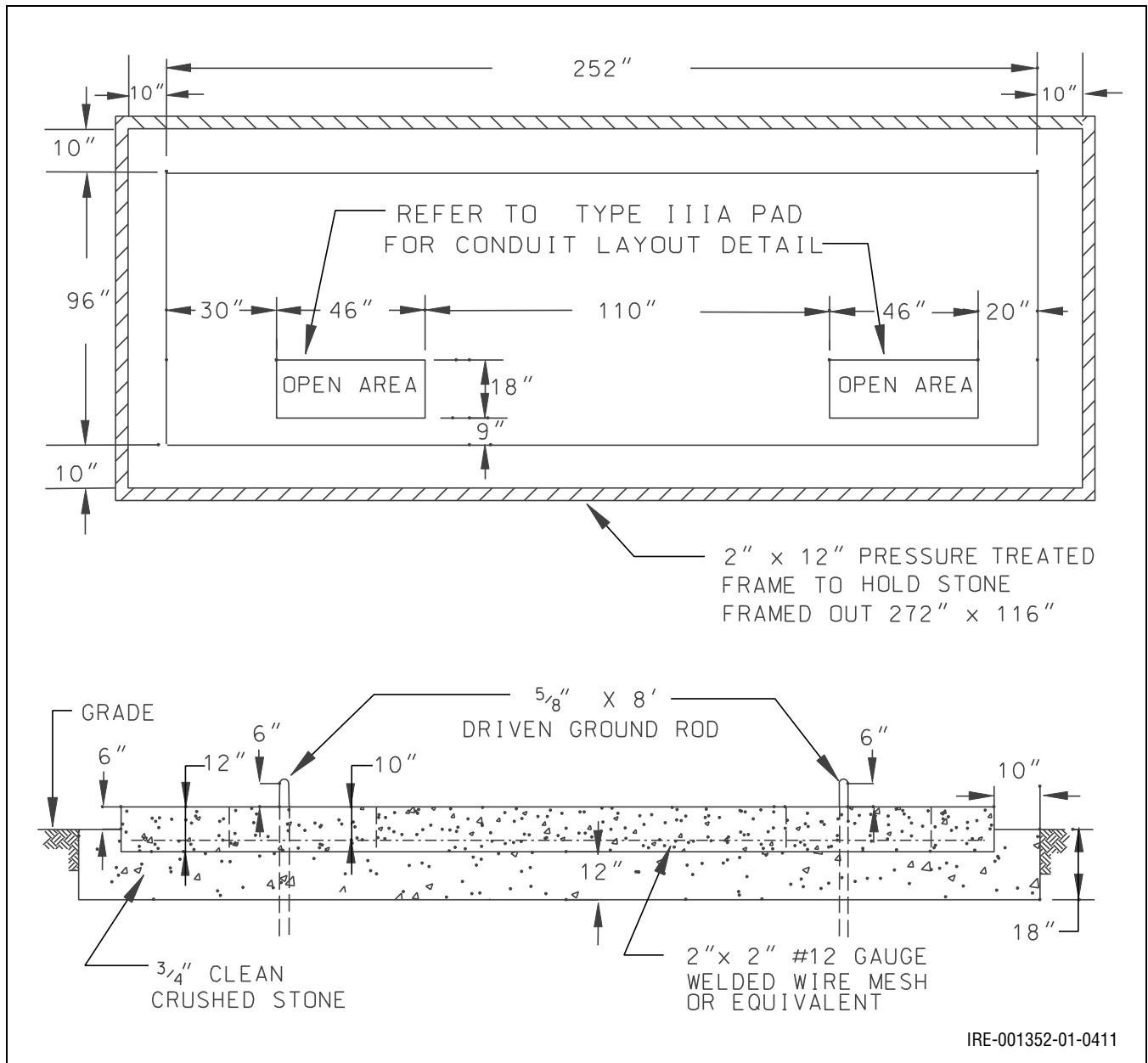

Figure 10.41 Notes:

1. The extension of the conduits above the surface of the pad shall be limited as follows:
 - Primary conduit 4 in. max.
 - Secondary conduit 6 in. max.
2. Mark grade on pipes.
3. Precast pads are preferred. Depth of pad is 8 in.
When allowed. Poured in place pads are 12 in. deep.

Figure 10.42: Three-Phase Padmounted Transformer – Type V-A (Concrete)



29 Guide for Construction of Customer-Installed Transformer Vaults – Secondary Metered

29.1 General

This section supplements the information contained in the [Chapter 3, Section 11](#) of this publication. Please note the following general requirements for transformer vaults.

1. These specifications are the minimum requirements of PSE&G and are not intended to be a design standard, nor are they intended to eliminate the necessity for the customer's responsibility to properly engineer each installation.
2. The vault shall be constructed to meet the requirements of State and local authorities, PSE&G and the current edition of the NEC.
3. The customer shall submit to PSE&G for approval detailed plans of the vault location and design in triplicate before proceeding with construction. These plans shall show the:
 - Size and location of the vault
 - Specifications of walls, ceilings and fire doors
 - Conduit and distribution equipment arrangement
 - Lighting and auxiliary wiring
 - Ventilation design
 - Water and sewer plans (to reveal possible encroachments into the vault)
 - Drainage design
 - Column plan
 - Customer's secondary bus, connections and grounding
 - Penetration fire stop system
4. The vault shall be accessible to mobile equipment for transformer installation and removal.

29.2 Construction Specifications – For Overhead Type Transformers

Please note the following construction details for vaults.

1. The minimum inside dimension of the vault shall be 15 ft x 25 ft for single vaults and 25 ft x 25 ft for double vaults. The proper size will be determined by the number and size of the transformers and other equipment to be installed. See [Figure 10.44](#) and [Figure 10.43](#) for more detail.
 - Vault ceiling shall have a minimum of 6 in. of reinforced concrete
 - Vault floor shall have a minimum of 4 in. of reinforced concrete
2. The inside height of the vault shall be 10 ft minimum.
3. Where the vault is accessible from within the building, the vault access doors shall be "Class A" fire doors of the proper size and a 3 hour fire rating, and have a "Danger High Voltage" sign on the outside. Louvers shall not be permitted on doors that are accessible from within the building. The minimum dimensions of the doorway shall be 8ft wide by 7 ft - 6 in. high. The doorway shall have a 4 in. sill, and the door shall be fitted with a lockset accepting a PSE&G supplied tumbler.
4. The door location and equipment arrangement shall be specified so that a defective transformer can be replaced without moving the remaining transformers or other equipment. Doors shall be equipped with

- crash-bar type opening devices with locking pins and vertical rods on the inside to provide quick and unimpeded escape from the vault in case of an emergency.
5. Ventilation shall be provided by means of suitable screened louvers having a minimum net open area of 31.25 sq ft. It is recommended that the louvers be arranged to provide cross ventilation over the transformers by having the inlet and outlet louvers on opposite ends of the long dimension of the vault. If the inlet and outlet louvers must be mounted in a common wall, air ducts shall be used as necessary to effect proper ventilation. One louver opening shall be near the ceiling and the other near the floor. If PSE&G determines that more ventilation is required than can be obtained through louvers, the customer shall, at its expense, provide thermostatically controlled forced air ventilation with a minimum capacity of 2000 cu. ft per minute for each 1000 kVA of ultimate transformer capacity to be installed in the vault. The service connection for such an installation shall be made on the customer's side of the meter.
 6. For both interior and exterior vaults, suitable lighting shall be installed in the vault with an operating switch within 3 ft of the door frame. Fluorescent tube lighting is not permitted. The lights shall be located on the door side wall opposite the transformers and 7 ft above the floor. A wall-mounted outlet with integral grounding connection shall also be provided for auxiliary lighting and power-tool connections.
 7. For vaults at grade, a drain to a 24 in. by 24 in. dry well shall be provided, and the floor of the vault should be sloped toward it. The dry well shall be installed with a grate cover. For vaults below grade, a drain to a dry well or a blind sump shall be provided, and the floor of the vault should be sloped toward it.
 8. No plumbing, heating or other foreign facilities or accessories such smoke and/or heat detectors shall be permitted within the transformer vault.
 9. All supporting framework and exposed metal parts of all equipment shall be grounded. This includes door frame and/or door, transformer tank, primary and secondary grounds. All grounding must be secure and in good condition, and shall have a minimum of #4 conductor. 2/0 copper ground must be attached to grounding block and grounding rod. Grounding rod system resistance shall be 25 ohms or less.

Figure 10.43: Transformer Vault Minimum Construction Dimensions Single – Up to Three 500 kVA Transformers

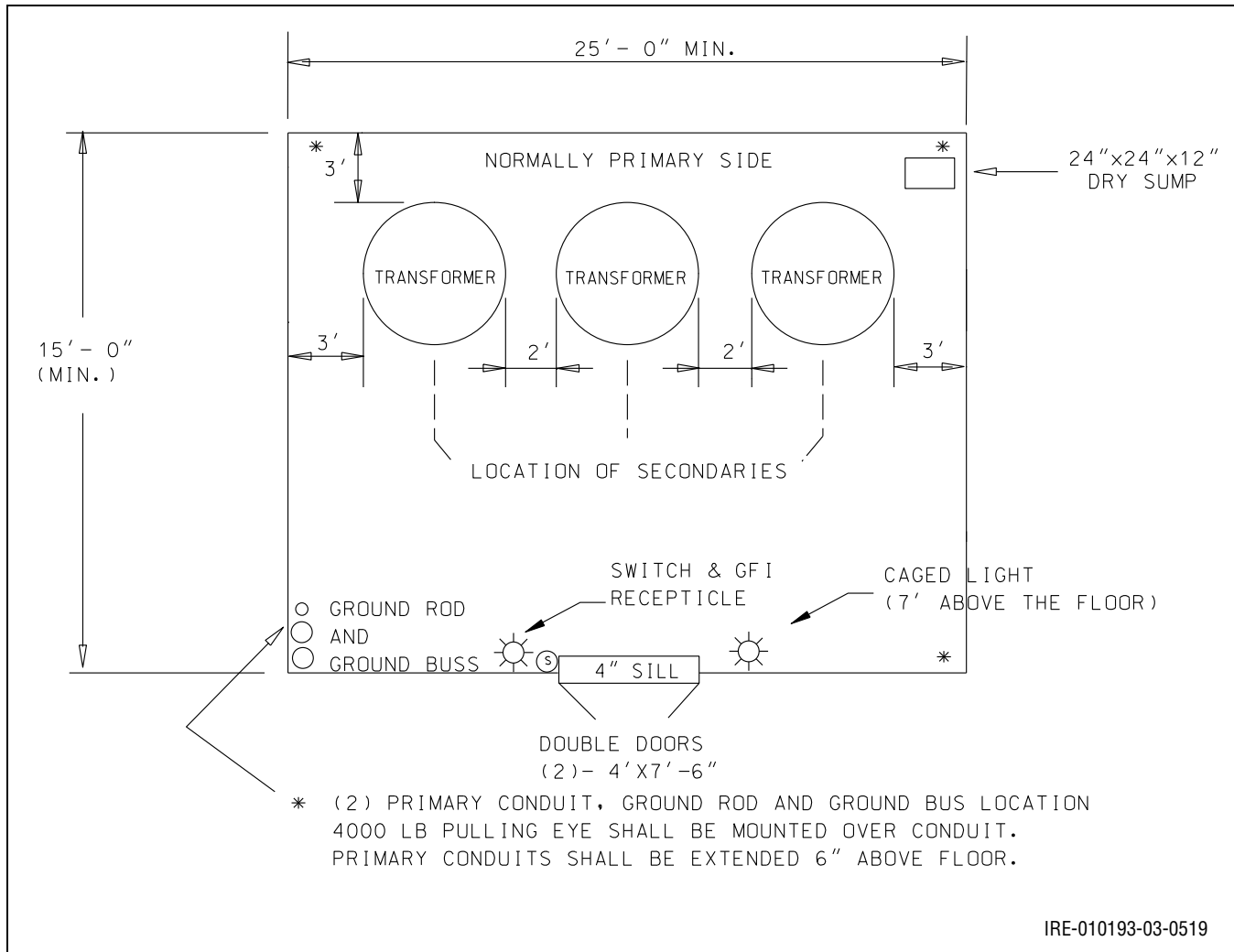

Figure 10.44: Transformer Vault Minimum Construction Dimensions Single – Up to Three 500 kVA Transformers Double – Up to Six 500 kVA Transformers

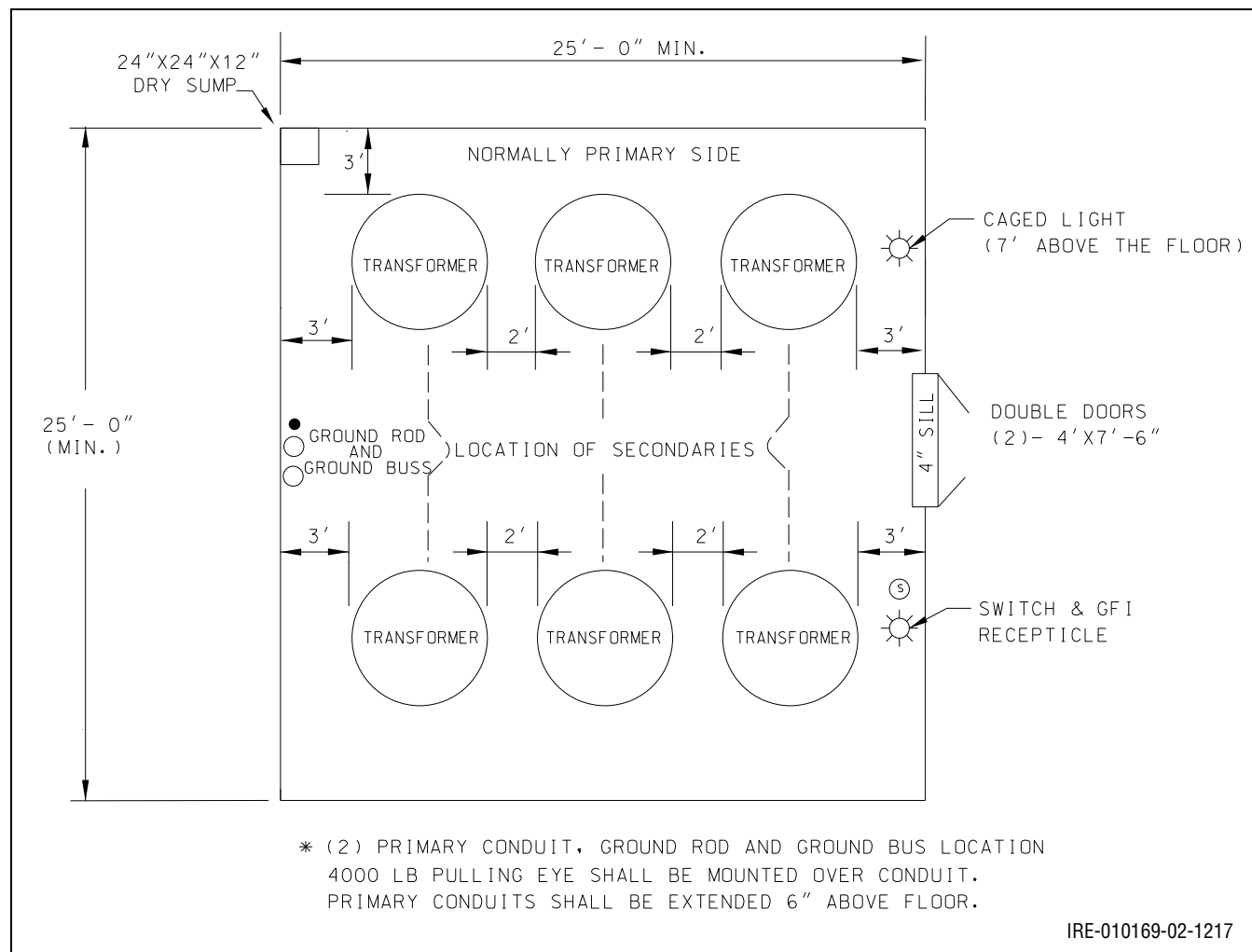

Figure 10.43 and Figure 10.44 Notes:

1. Vault construction shall conform to the latest edition of the NEC, PSE&G requirements and those of any inspection authorities having jurisdiction.
2. Bus duct is recommended for mounting on the wall adjacent to the secondary side of transformers.
3. Typically, the rack for the primary conductors shall be hung from the ceiling using unistrut and hangers designed for supporting 4 in. split transite. In some construction "L" hangers may be used.
4. Six transformers are used for 265/460 or 277/480 V service only.

29.3 Vault Requirements – Customer-Installed Transformer Vault – Construction’s Specifications Network Type Vaults Only

1. Construction Details for Vaults

The vault shall be accessible to mobile equipment for transformer installation and removal. The minimum inside dimension of the vault shall be 25 ft x 25 ft x 14 ft H for 1,500 KVA transformers and below. For 2,000 KVA and above the vault dimensions shall be 32 ft W x 25 ft D x 14 ft H. Install lifting eye in ceiling over conduits (4,000 lb). See [Figure 10.45](#) and [Figure 10.46](#) for more detail. Walls and ceilings must be 3 hour fire rated concrete (no exceptions).

2. Vault Room Door Requirements

Two sets of “Class A” fire doors of the proper size, with a “Danger High Voltage” sign on the outside are required. The minimum dimensions of each door shall be 4 ft wide by 8 ft high. The doorways shall have a 4 in. sill. Doors shall be equipped with crash-bar type opening devices and both doors shall contain a vertical rod latching device on the inside. The outside will be equipped with a handle and the door shall be fitted with a lockset accepting a PSE&G supplied tumbler.

3. Ventilation Requirements

Ventilation shall be provided by means of suitable screened louvers. 3 sq. in. per kva. If PSE&G determines that more ventilation is required than can be obtained through louvers, the customer shall, at its expense provide thermostatically controlled forced air ventilation with minimum capacity of 2,000 cu.ft per minute for each 1,000 kva of ultimate transformer capacity to be installed on the outside of the vault. The service connection for such an installation shall be made on the customer’s side of the meter.

4. Lighting Requirements

For both interior and exterior vaults, suitable incandescent lighting shall be installed in the vault with an operating switch near each door. The lights shall be located on the wall opposite the transformers and 7 ft above the floor. A wall-mounted outlet with integral grounding connection shall also be provided for auxiliary lighting and power-tool connections.

5. Dry Well Requirements

For vaults at grade, a drain to a suitable dry well 24 in. x 24 in. x 24 in. shall be provided, and the floor of the vault should be sloped toward it. For vaults below grade, a drain to a dry well or a blind sump shall be provided, and the floor of the vault should be sloped toward it. Grate cover must be installed over the well. No other drainage pipes or devices are to be installed.

6. Miscellaneous Requirements

No plumbing, heating, sprinkler systems or other foreign facilities or accessories shall be permitted within the transformer vault. Customer is responsible for installing secondary and primary cabling racks as required by PSE&G.

7. Grounding Requirements

Must have driven ground inside or outside vault with; insulated ground block, 2/0 copper ground must be attached to the block and ground rod.

Grounding – All supporting framework and exposed metal parts of all equipment. Door frame and/or door. All grounding must be secure and in good condition.

8. Secondary and Primary Connection

PSE&G is responsible for the installation of the primary and secondary inside the vault. Customer's equipment must be able to except lug limiters. On a 277/480 V service a bus room is required; PSE&G will furnish the buss and the customer will pick up and install.

9. Buss Room Dimension

4000 A Buss Room: 11 ft D x 23 ft W x 14 ft H

5000 A Buss Room: 11 ft-4 in. D x 32 ft W x 14 ft H

The customer will be furnished with buss specifications.

Figure 10.45: Network Vault Specifications – 120-208 V

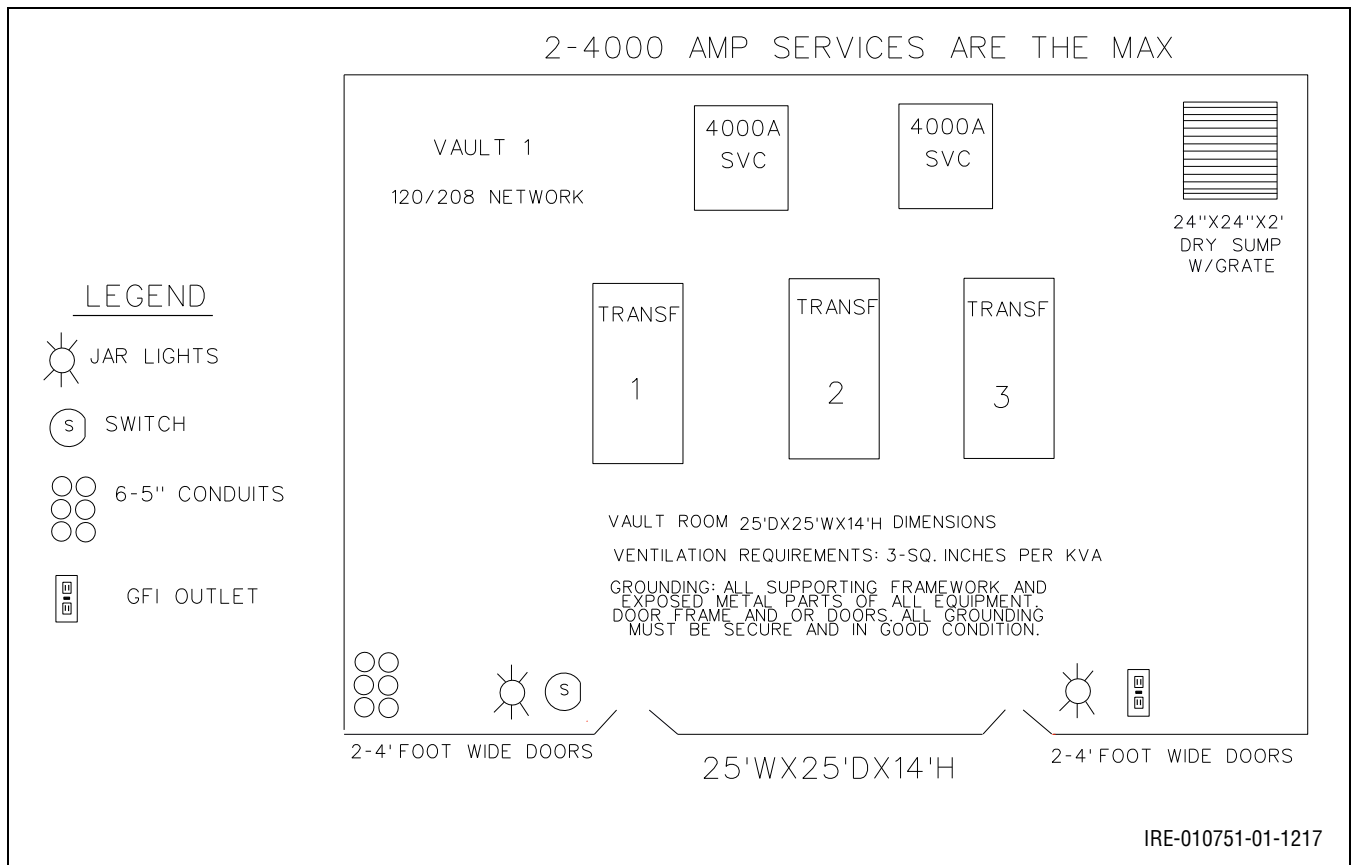
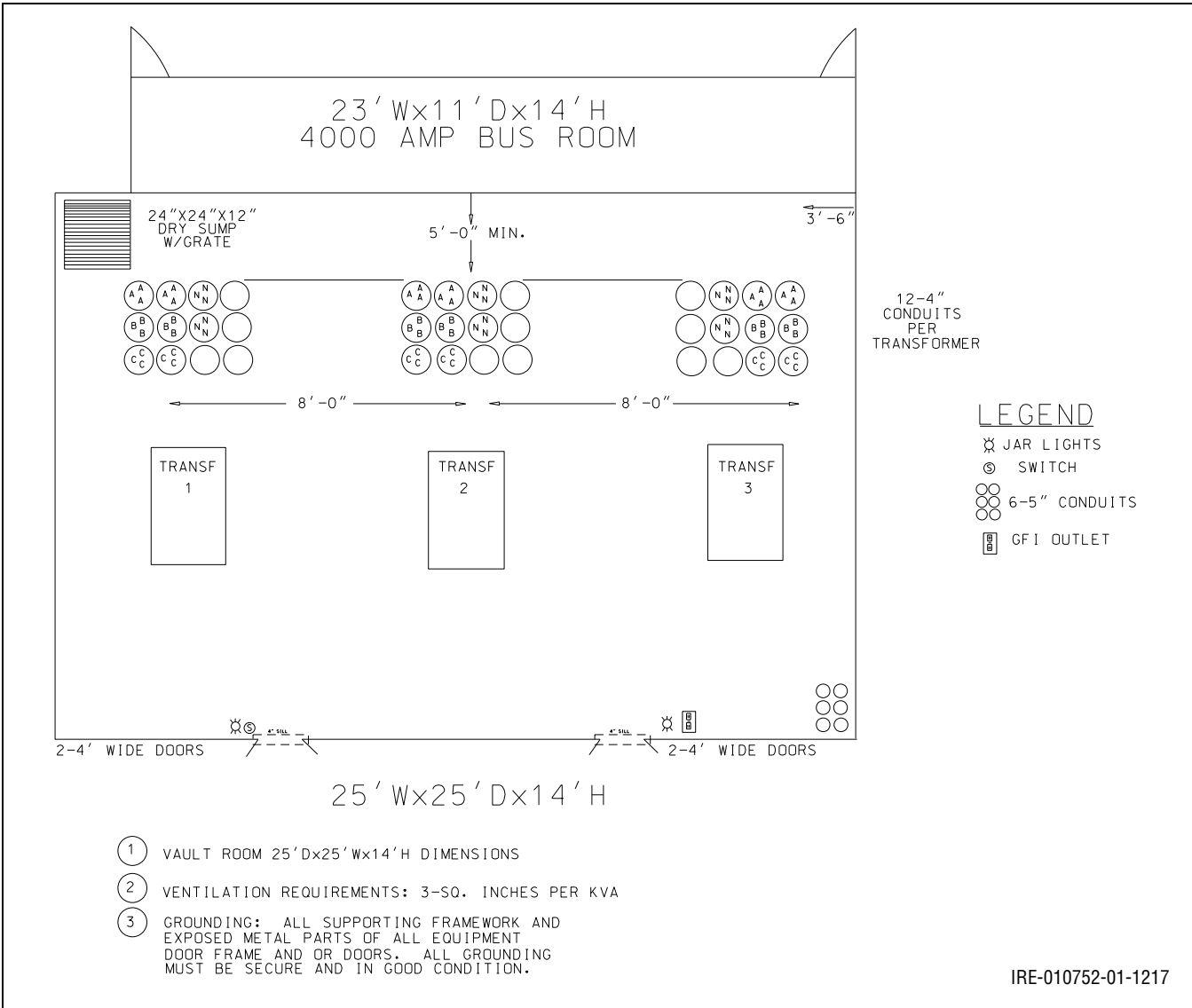
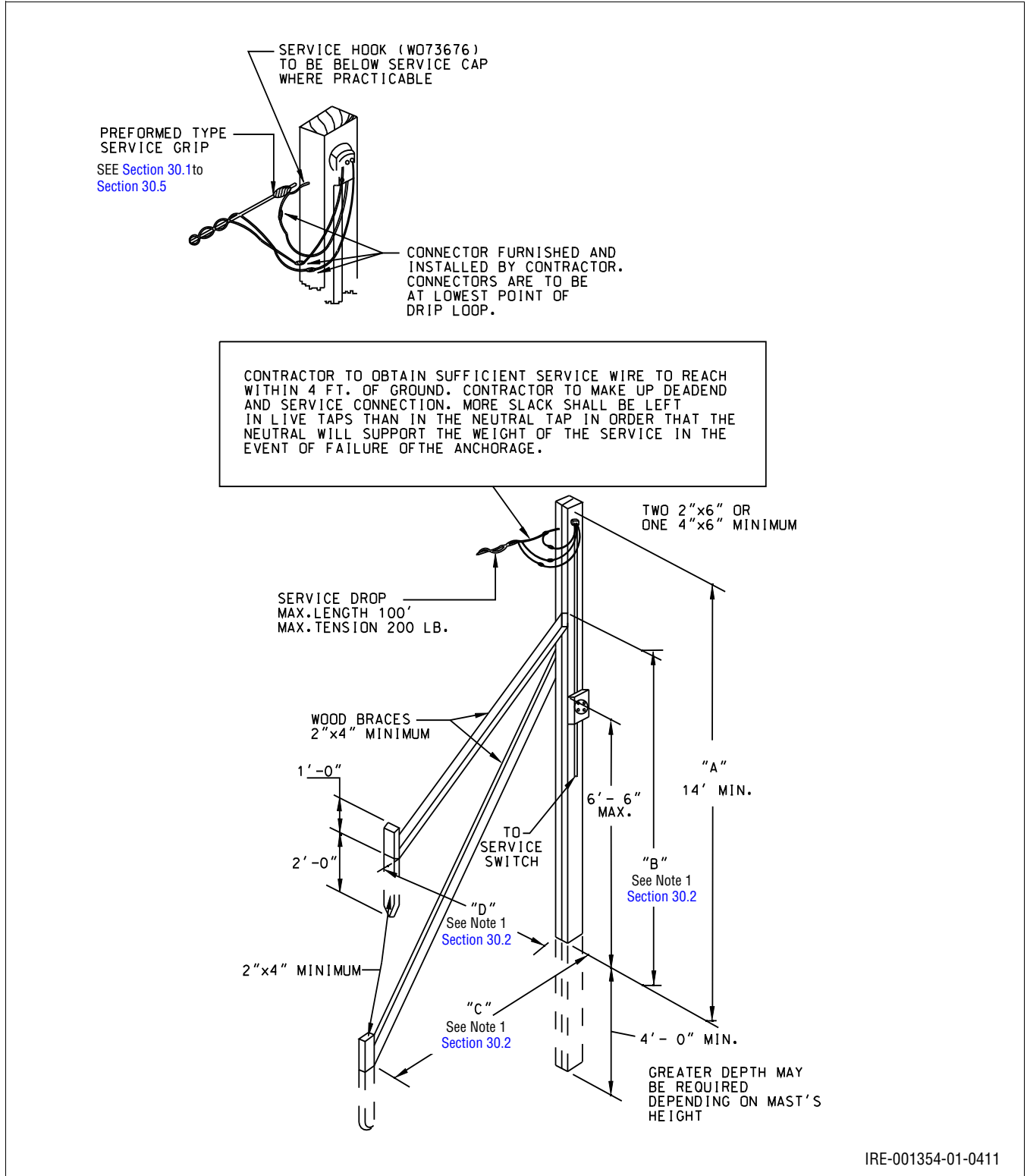

Figure 10.46: Network Vault Specifications – 277-480 V



30 Minimum Requirements for a Temporary Service Mast

Figure 10.47: Minimum Requirements for a Temporary Service Mast



30.1 General

Please note the following general requirements for temporary service facilities.

1. These instructions shall be considered the minimum requirements for temporary triplex wire services, not exceeding 100 ft from the PSE&G service pole.
2. All lumber used for the service mast shall be free of large knots, splits, or cracks.
3. The minimum height of the mast shall be 14 ft above the ground, however the mast shall provide at least 18 ft of clearance over streets and driveways, and 12 ft of clearance at all other locations and must be sized accordingly.
4. Temporary masts to accommodate services using larger than triplex service wire shall be engineered individually to fit the circumstances, and the design must be approved by PSE&G prior to installation.

30.2 Construction

Please note the following construction requirements.

1. The mast shall consist of two 2 in. x 6 in. timbers bolted or nailed securely together, or one 4 in. x 6 in. timber, and set a minimum of 4 ft in the ground and placed with the 6 in. edge parallel to the pull direction of the service wires. Either design shall be braced in line and at right angles with 2 in. x 4 in. timbers. Braces shall be bolted or nailed at 2/3 of the height of the mast, and to individual stakes in the ground at least 6 ft from the base of the mast, or preferably the length of “B” as shown in [Figure 10.47](#). Stakes shall be made from 2 in. x 4 in. timbers at least 3 ft long, and shall be driven into the ground 2 ft.

Note All dimensions are minimum unless otherwise specified by PSE&G.



2. The temporary mast may be attached to a substantially constructed building capable of supporting such a load. The same size timber as described in paragraph 5 shall be used, and bolted to the building frame with 5/8 in. galvanized machine bolts at two points 6 ft apart in place of the bracing. The mast need not extend into the ground.
3. One 6 in. x 6 in. timber may be used without braces. It must be treated with creosote or other approved preservative, and set into the ground at least 6 ft deep.
4. One 4 in. tar-coated standard-weight steel pipe (not electrical conduit or tubing) set 6 ft into the ground may be used without bracing. It shall have a concrete collar 12 in. in diameter that extends 12 in. deep below the surface of the ground.
5. A 30 ft class 7 fully creosoted pine pole, set a minimum of 5-1/2 ft in the ground, may be used without bracing.
6. Install a 5/8 in. x 8 ft ground rod to obtain 25 ohms or less ground resistance. Add additional rods if necessary to achieve the 25 ohms resistance level.
7. Install an adequately sized, 3/4 in. pressure treated plywood meter board behind the meter socket, whenever the mounting holes of the socket exceed the width of the mast.
8. PSE&G will supply, at its headquarters without additional charge to the person installing a temporary service upright, a sufficient length of the proper service wire to reach within 4 ft of the ground. PSE&G also will supply a suitable deadend device for making the connections on the upright. The electrical

contractor installing the upright shall properly deadend the length of the service wire, and make the service connections on the upright, so that the length of the service wire can be spliced out, on the ground, by PSE&G.

30.3 Working on Temporary Service Masts

Please note the following requirements for working on temporary service masts.

1. No PSE&G employee shall place a ladder against or otherwise climb a temporary service mast for the purpose of installing, repairing or removing the electric service connections. (See paragraph 3 below)
2. Should the electrical connections at the top of temporary upright become defective, PSE&G upon request will disconnect such a service at the pole in order that repairs may be made by the customer or his contractor. Following the repair work the service will be re-connected after approval of PSE&G inspection. This work will be done without additional charge. (See paragraph 1 above.)
3. Paragraphs 6, 7 and 8 in [Section 30.2](#) shall not apply if the temporary service mast is a pole set by PSE&G or the telephone company. (See [Section 30.2](#) paragraph 5)

30.4 Connections

Connectors shall be supplied by the contractor for the service connection.

30.5 Approvals

Local subcode official and PSE&G approvals are required prior to energization of the service.

31 Underground Temporary Service Mast

Figure 10.48: Underground Temporary Service Mast

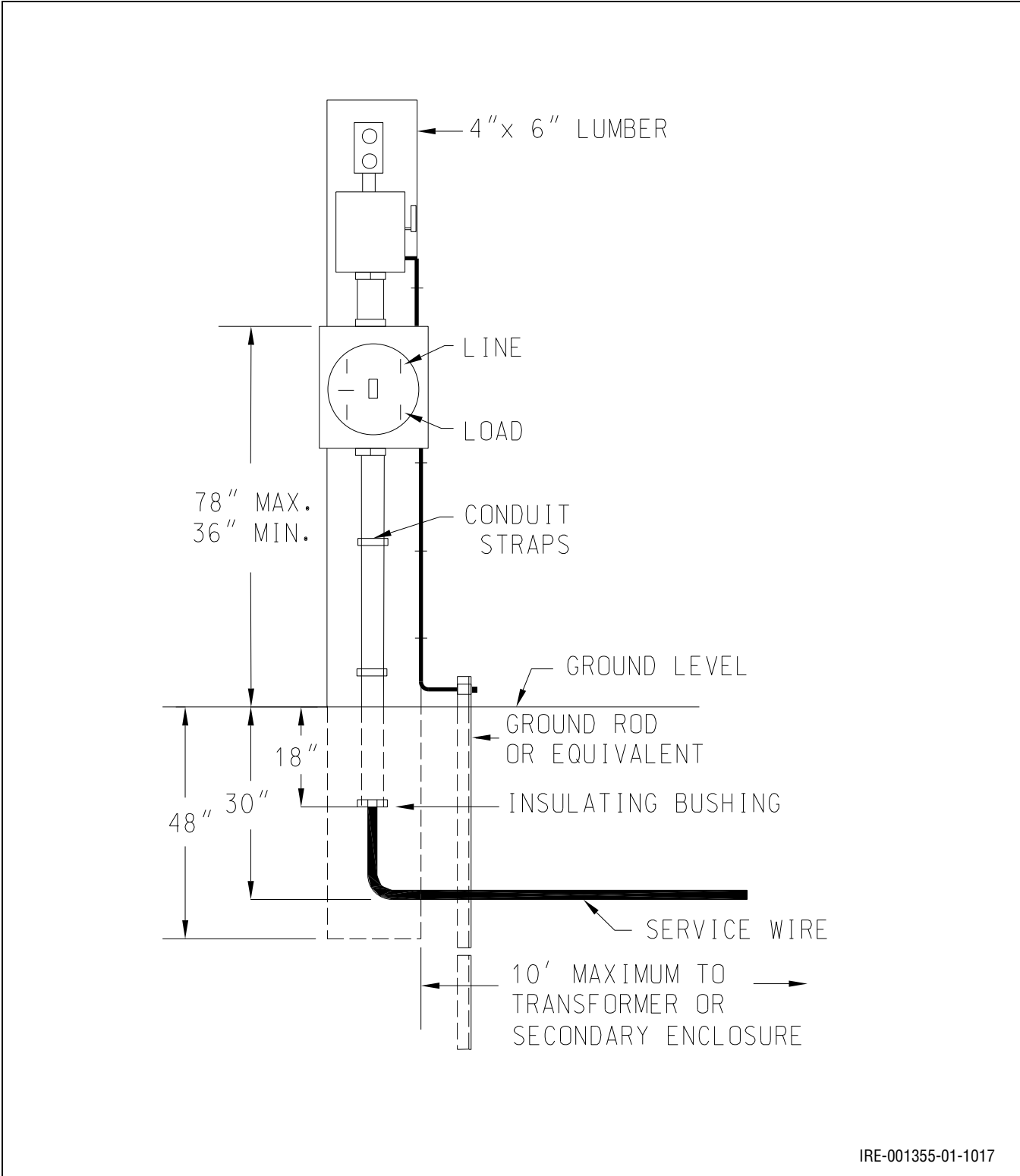

IRE-001355-01-1017

Figure 10.48 Notes:

PSE&G will:

1. Designate the location of the temporary service mast.
2. Supply 20 ft of temporary service wire.
3. Connect and disconnect the service at the source of supply.

Customer shall:

1. Construct and install the temporary service as shown, and in accordance with the requirements of the NEC.
2. Dig the service trench and install the service wire from the mast to within 2 ft of the PSE&G supply point.
3. Obtain a certificate of approval from a recognized inspection agency.
4. Install a 5/8 in. x 8 ft ground rod to obtain 25 ohms or less ground resistance. Add additional rods as necessary in order to achieve the 25 ohms resistance value.
5. Install an adequately sized meter board, using 3/4 in. pressure treated plywood behind the meter socket, whenever the mounting holes of the socket exceed the width of the mast.

32 Community Antenna Television (CATV)

Figure 10.49: Typical Service Installation CATV 120 V Power Supply Pedestal

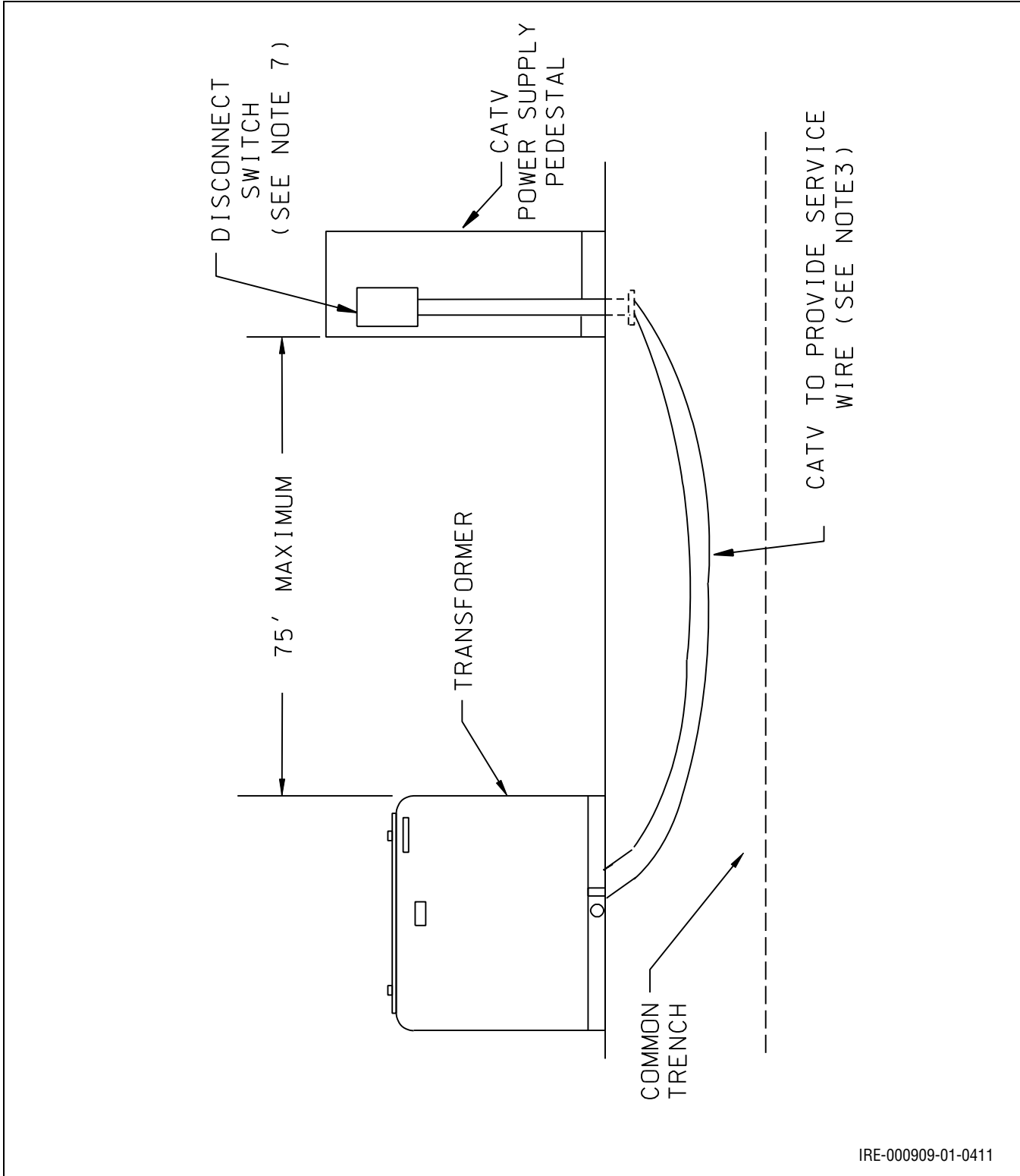

Figure 10.49 Notes:

1. The CATV company shall provide and install the service wire from the CATV power supply pedestal for terminating at the transformer by PSE&G.
2. For PSE&G's use, the CATV company shall provide enough service wire to leave at least a 3 ft length of service wire coiled next to the transformer, and left visibly above the ground.
3. The service wire shall be duplexed #8 copper (black) with a #6 copper (white) insulated neutral. The service wire shall be identified as the property of the CATV company.
4. PSE&G will connect the service wire to transformer.
5. See [Figure 10.37](#) and [Figure 10.38](#) for location of transformer and trench layout.
6. If the CATV company chooses to dig its own trench, the minimum cover over the service wire shall be 24 in.
7. The CATV company shall supply a lockable disconnect switch to be mounted on the outside of its pedestal. The underground service wire shall exit the trench through either Schedule 80 PVC, or rigid galvanized steel conduit to the switch. The conduit shall extend below grade a maximum of 18 in. and be equipped with a protective bushing.

Figure 10.50: Community Antenna Television (CATV) Power Supply on Joint Pole

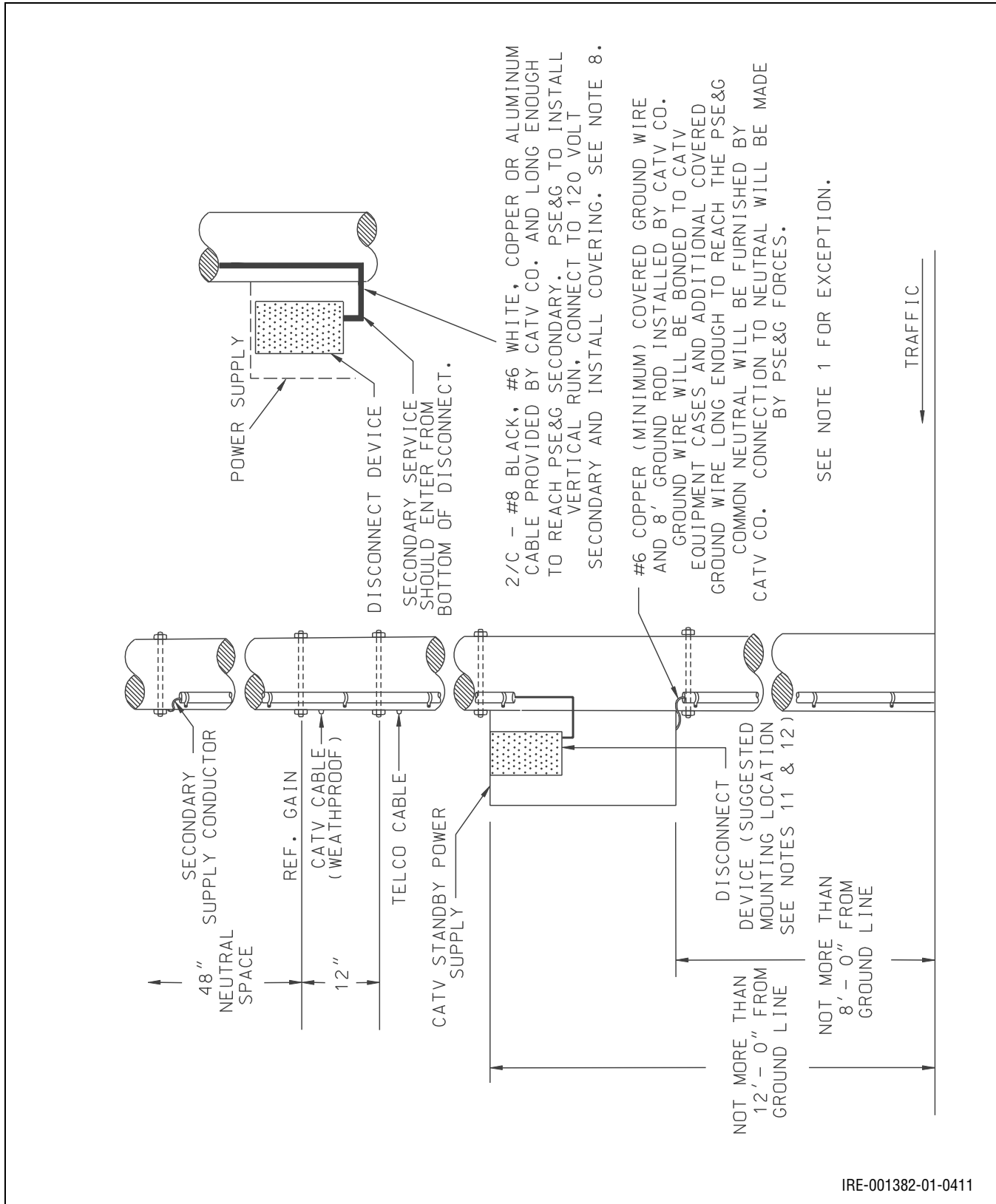

Figure 10.50 Notes:

1. Where a PSE&G pole ground exists, no separate CATV pole ground is required. The CATV company shall bond its equipment as shown in this exhibit, and PSE&G will connect the bond to the pole ground.
2. The size and shape of the CATV power supplies will vary with the installing CATV company, but the criteria for these units shall be as follows:
 - The unit shall not be heavier than 640 lb.
 - The dimensions of the unit shall not to exceed 33 in. wide, 38 in. tall, and 18 in. in depth, unless mutually agreed upon between PSE&G and the telephone company.
3. If needed, sealed batteries with gelled electrolytes, or a recombination arrangement shall be used. Batteries with liquid electrolytes may be used only if they are securely fastened within the power supply enclosure, and encased in an absorbent material to contain any fluid in case of leakage or rupture. All through bolts shall be kept to approximately 1 in. beyond the nut, either by correct sizing or cutting after installation.
4. Meter service is available at the CATV company's option, and will be cut in on the basis of a meter order (95-2543). The meter shall not be located on the pole itself, but on an adjacent pedestal furnished by the customer, in accordance with PSE&G specifications.
5. Unmetered service is available only after a rate schedule authorization has been approved by PSE&G with a previously agreed upon billing procedure, and will be cut in on the basis of a street lighting order (95-1430).
6. No municipal or inspection authority cut-in card will be required, but all equipment on the pole will be subject to PSE&G's approval, and a certificate for each cut-in will be required from the CATV company.
7. The power supply shall be installed only on poles that have no other type of equipment controls already installed.
8. CATV company shall attach the coiled supply wire to the pole at least 48 in. below the PSE&G secondary supply. PSE&G will provide and install the 1 in. Schedule 80 PVC "U" molding (W074832), to be attached with staples (W067703) over the supply wire.
9. Pole selection and the attachment position of the power supply shall be mutually approved by PSE&G and telephone company representatives prior to its installation, and preferably off a main traffic route.
10. The power supply unit must be mounted on the face or back of the pole, and on the opposite side from oncoming traffic. The top of the unit must not be more than 12 ft above the furthest ground line.
11. The disconnect device shall be an NRTL listed device suitable for outdoor service. A fuse is not required in the disconnect device provided that the power supply itself is equipped with an NRTL listed fault interrupting device.
12. The disconnect device shall have an inter-lock system to prevent a backfeed into the PSE&G system from either a standby power supply battery circuit if used, or an emergency external power source.
13. Power supplies that do not conform to notes 2, 9, and 10 shall be installed either on a separate structure, or be padmounted with an underground service, and be outside a radius of 10 ft away from the utility pole.

33 Limiter Lug Assembly – 350 MCM and 500 MCM 600 V Rubber Insulated Service Cable

Figure 10.51: Limiter Lug Assembly – 350 MCM and 500 MCM 600 V Rubber Insulated Service Cable

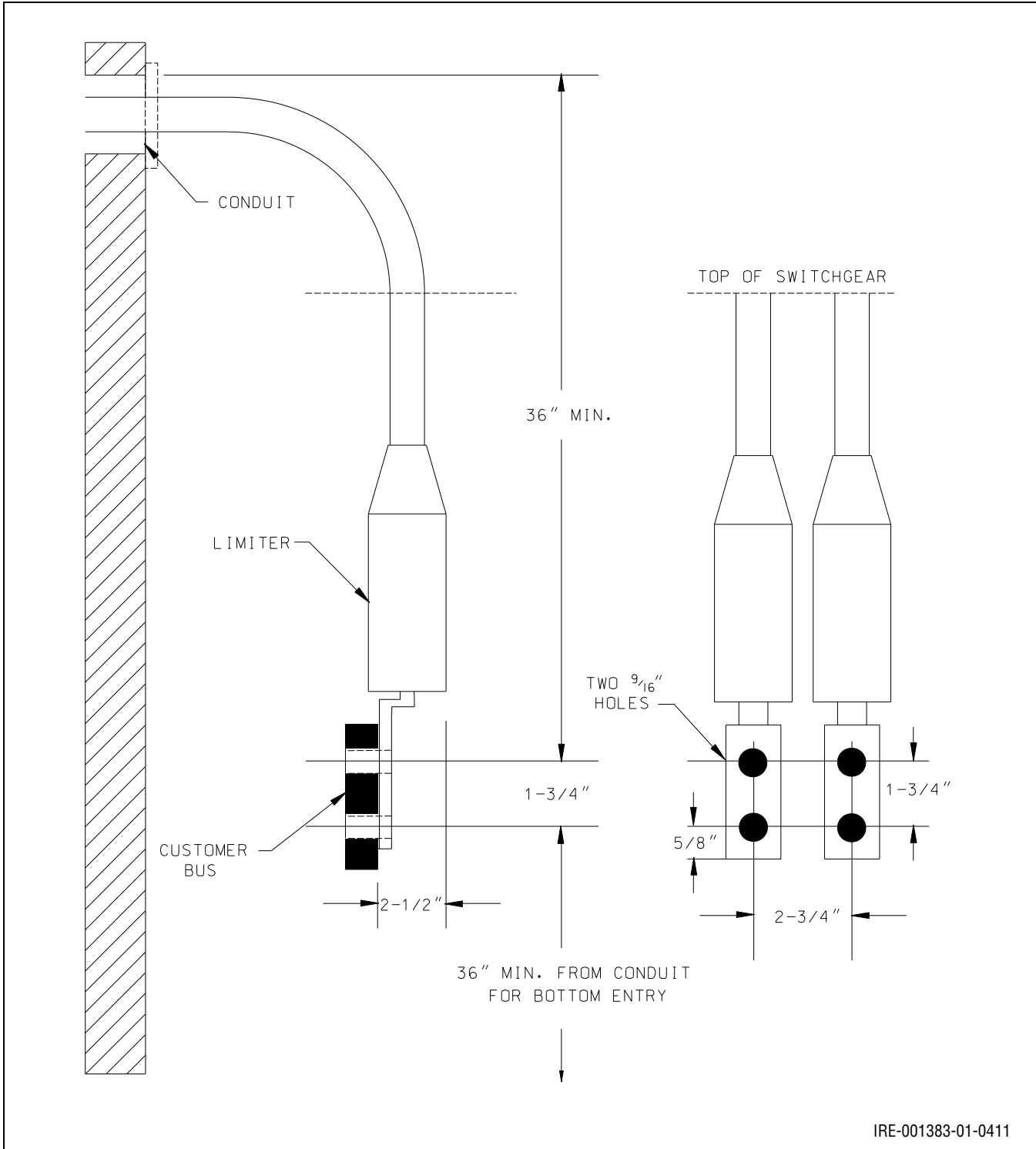

Figure 10.51 Notes:

1. When a new service requires limiters to be installed for secondary voltage customer switchgear, PSE&G requires a minimum of 36 in. of space from the point of connection on the customer's bus to the entry point of the cable into the switchgear. This working space is needed for removing the rubber insulating sleeve for the cable connection, and to shape the cable.
2. For service entrance cables that are bottom entry into the switchgear, provisions shall be made to provide 36 in. of clearance from the end of the conduit to the attachment point to the bus as in above.
3. For service entrance cables that are top entry into the switchgear, an extra "hi-hat" enclosure on top of the switchgear to allow for the required 36 in. spacing, may need to be provided by the manufacturer.
4. In all cases, there needs to be adequate working space provided in the switchgear cubicle for installation of the limiters, and if a limiter fails it needs to be accessible for replacement.
5. When the customer provides switchgear prints, and the job is determined by PSE&G to be in a network area and requires limiters, the customer should also provide a plan and profile drawing of the switchgear room, to enable PSE&G to comment on the design of the incoming cubicle based upon the planned entry point for the service cable.

34 Net Metering

Figure 10.52: Net Metering



IRE-001381-01-0411

Figure 10.52 Notes:

This net metering job depicts two external safety disconnect switches for a solar installation. One switch has been utilized for each photovoltaic inverter. Most residential solar installations will only have one inverter. When switches are installed they should generally be within 10 ft of the meter and have warning signs as shown. PSE&G does not specify the manufacturer of the disconnect switches.

Figure 10.53: Metered Installation for third Party Equipment on Secondary Distribution Pole

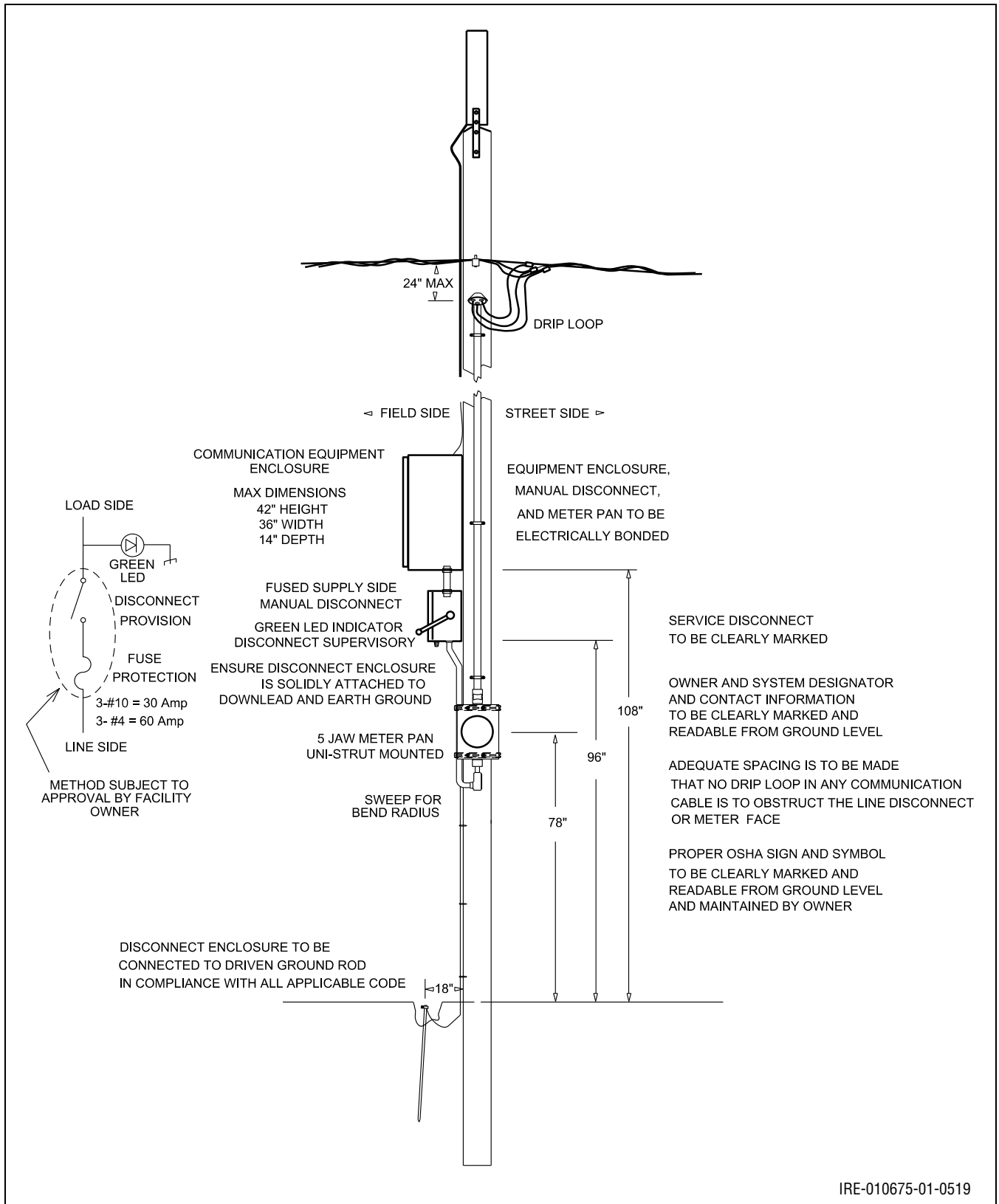

35 New Jersey One-Call System

Figure 10.54: Call Before You Dig (Page 1)

CALL BEFORE YOU DIG

1-800-272-1000 Safely

It's THE LAW

NEW JERSEY ONE CALL

COLOR CODE FOR MARKING UNDERGROUND UTILITY LINES

- ELECTRIC
- GAS-OIL-STEAM
- COMMUNICATION CATV
- WATER
- SEWER
- PROPOSED EXCAVATION

REQUIRED INFORMATION FOR MARKOUT REQUEST

NAME OF CALLER TITLE

PHONE NO. FAX NO.

BEST TIME TO CALL BACK

EXCAVATOR

EXCAVATOR ADDRESS

WORK DONE FOR

ADDRESS PHONE NO.

DIG LOCATION

MUNICIPALITY STREET ADDRESS

NEAREST INTERSECTION

TYPE OF WORK DEPTH

EXTENT OF WORK

START DATE START TIME

TIMEFRAME MATRIX

MON.	TUES.	WED.	THUR.	FRI.	SAT.	SUN.	MON.	TUES.	WED.	THUR.	FRI.
CALL - MARKOUT	MARKOUT	MARKOUT	MARKOUT	DIG							
	CALL - MARKOUT	MARKOUT	MARKOUT	MARKOUT	DIG*	DIG*					
		CALL - MARKOUT	MARKOUT	MARKOUT	*	*	MARKOUT	DIG			
			CALL - MARKOUT	MARKOUT	*	*	MARKOUT	MARKOUT	DIG		
				CALL - MARKOUT	*	*	MARKOUT	MARKOUT	MARKOUT	DIG	
					CALL - MARKOUT	*	CALL - MARKOUT	MARKOUT	MARKOUT	MARKOUT	DIG
						CALL - MARKOUT	CALL - MARKOUT	MARKOUT	MARKOUT	MARKOUT	DIG

Dig Safely

1 800 272-1000
NEW JERSEY ONE CALL

CALL FOR FREE MARKOUTS
3 BUSINESS DAYS BEFORE
YOU DIG

* Contractors option to dig on Saturday or Sunday
+Holidays and Saturdays/Sundays do not count in three business days allowed for markout.
- Any request received at One-Call Center on a Holiday, Weekend or after 5 p.m. on a business day, is considered requested the next business day.

New Jersey State Holidays

New Year's Day	Veteran's Day	Memorial Day
Lincoln's Birthday	Christmas Day	Labor Day
Good Friday	Martin Luther King, Jr.'s Birthday	Election Day
Independence Day	Washington's Birthday	Thanksgiving Day
Columbus Day		

SA-001482-01-0411

Chapter 10 – Additional Information and Illustrations

Go to Chapter TOC – Go to TOC

10 – 86

Information and Requirements for Electric Service

October 17, 2019 – Rev 4.02









Figure 10.55: Call Before You Dig (Page 2)



**CALL 3 BUSINESS DAYS
BEFORE YOU DIG**
1-800-272-1000
CALL FOR YOUR FREE MARKOUTS

**EXCAVATOR
DIGGING Dos**



-  **Call 1-800-272-1000 before you dig**
-  **Call 3 business days in advance, but no more than 10 business days**
-  **Commence excavation within 10 business days or ticket is no longer valid**
-  **Obtain new ticket after 45 business days**
-  **All excavators (including Sub-Contractors) must have their own tickets**
-  **Hand dig and locate within 2 feet of a markout before operating any mechanized equipment**
-  **Protect and preserve markings**
-  **Plan excavation/demolition/blasting to avoid damage and minimize interference to underground facilities**
-  **Excavators shall immediately report any damage caused or discovered to the underground facility**

**IT'S THE LAW!
NEW JERSEY
ONE CALL
1-800-272-1000**



State of New Jersey
Governor James E. McGreevey
New Jersey Board of Public Utilities (NJBPU)
Jeanne M. Fox
President



Published by the New Jersey Board of Public Utilities (NJBPU) www.bpu.state.nj.us

SA-001483-01-0411

36 Padmounted Transformer Installations – Secondary Metered

Please note the following general requirements for installation of three-phase padmounted transformers.

1. For padmounted transformer installations in overhead (non- residential BUD) and underground zones, the primary and secondary wiring to the transformer pad must be installed underground. PSE&G will provide and install the pad and the padmounted transformer, and will install and connect the primary cables to the transformer.
2. The customer, at their expense, shall do the site preparation work to accept the transformer pad. They shall also be responsible for the installation of primary underground conduits and required manholes, or for the trenching in the case of a direct buried primary cable installation, from the transformer pad to the selected PSE&G pole, according with PSE&G specifications.
3. The customer will be responsible for all the installations from the secondary terminal of the transformer to the customer's premises.
4. The customer must install only copper conductors at the secondary terminals of the transformer if maximum number of cable requirements cannot be met. The maximum numbers of cables per phase and by cable size for different transformer sizes are shown on [Table 10-7](#). PSE&G shall be contacted if smaller than 350 kcmil cable needs to be used.
5. At the secondary terminal of the transformer, in cases where the customer will need more secondary connectors than available per phase in the transformer.

The customer, at their expense, must acquire a secondary enclosure that will provide them with the extra needed connection points that the transformer by itself does not have available. The enclosure will be installed between the padmounted transformer and customer's premises and shall be chosen based on the size of the customer service panel box. Recommended enclosures by PSE&G are rated from 1200 A to a maximum of 4500 A and meet the dimension requirements shown on [Table 10-6](#). The enclosure will be locked before the transformer is energized and customer will have to contact PSE&G when access to the interior of the enclosure is needed. Secondary conductors between secondary terminals of the transformer and buses of the required enclosure shall be copper and meet requirements as specified in [Table 10-7](#).

6. All work between the secondary side of the transformer and the customer's premises, including supplying the connectors and bolting them to the transformer terminals and to the buses of any required secondary enclosure will be done by and at the expense of the customer in accordance with PSE&G specifications. Secondary conductors shall not be installed until the transformer and required enclosure have been set on their pads. For information on pads for secondary enclosure, contact PSE&G. The customer shall not be permitted to run a separate grounding conductor between the customer's premises and the PSE&G transformer.
7. In those cases where the connections to the transformer and required secondary enclosure would normally be made by the customer at its own expense, PSE&G may elect, in special cases, to do such work with its own forces on a time and material basis at the customer's expenses.
8. The customer must assure the transformer pad shall be accessible for inspection, and for installing and replacing the padmounted transformer, including driving heavy equipment over to it without damage to the landscaping or the equipment. Access design must be approved by PSE&G.
9. The customer shall be responsible for the maintenance of all secondary cables/wires and equipment between the padmounted transformer and the customer's premise.

10. For buried primary cable installation, the customer must consult the local Electric Distribution Division to determine if soil conditions require that the entire service run is placed in conduit.

Figure 10.56: Padmounted Transformer Installations – Secondary Metered

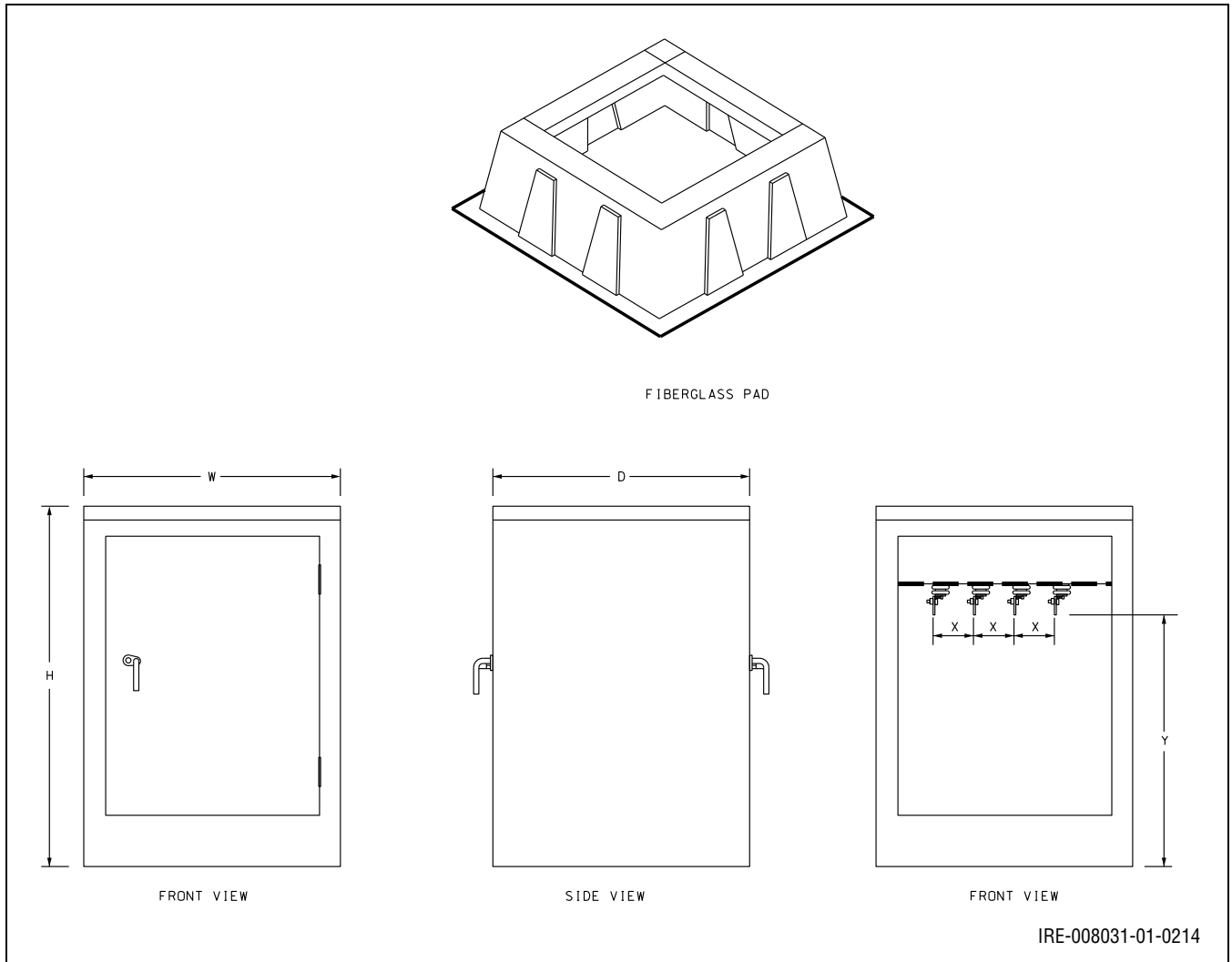

Table 10-6: Secondary Enclosure- Dimensions

Enclosure Dimensions			Bus Location	
W (min)	D (min)	H (min)	X (min)	Y (min)
42	42	48	7.25	34

Table 10-7: Maximum Number of Secondary Cables per Phase

KVA	150/225/300		500		750		1000		1500		2000	2500	3000
	120/ 208	277/ 480	120/ 208	277/ 480	120/ 208	277/ 480	120/ 208	277/ 480	120/ 208	277/ 480	277/ 480	277/ 480	277/ 480
Max Number of Conductor Sets Per Secondary Bushing (1)	4	4	6	4	10	6	10	6	10 (2)	6	10	10	10

Note: * Ratings are based on industry standard secondary terminal sizes (NEMA pads) as specified in IEEE C57.12.24 Section 7

(1) Number indicates the maximum number of cables that can be connected to the transformer secondary spade without modification of any type (such as using stacking lugs, spade extender plates, etc.). All cables must be run directly from the bottom of compartment up to secondary spade without extra slack or coils. Where possible, the number of feeder cables terminated on the transformer lugs should be minimized by using the largest cable size possible

(2) 1500 KVA transformer with 120/208 V secondary is not standard as this size load is normally served at 277/480 V secondary. Special arrangements will be required for this installation. Contact local electric division for options prior to finalizing service design and configuration

Chapter 11 – General Specification for Service to High-Rise Buildings – Contents

1	General	11-1
2	Definitions	11-1
3	General Specification	11-2
3.1	Initial Customer Requirements	11-2
3.2	Initial Company Response	11-2
4	Types of Service	11-2
4.1	High-Rise Residential Service	11-2
4.2	Primary Service	11-3
5	General Specification Certification	11-4
6	Site Specific Specification	11-4
7	Service Sketch	11-4
8	Customer Requirements	11-4
9	Company Requirements	11-5
10	Site Specific Certification	11-5

This Page Intentionally Blank

Chapter 11 – General Specification for Service to High-Rise Buildings

1 General

Service to High-Rise Buildings requires different designs to compensate for the voltage drop from the source to the load. Specific designs can differ from building to building. Based on the height of the building, the load, and the type of customer served, the New Jersey State Tariff requires different considerations. This specification outlines the PSE&G (the Company) and the customer requirements for service to High-Rise Buildings. In addition, requirements for vaults at or below grade are included.

This specification is divided into two parts: a general and a site-specific specification.

If any section of this specification disagrees with applicable chapters of the latest versions of the *Underground Construction Outside Plant Manual*, the *Operation Outside Plant Manual*, or this *Information and Requirements for Electric Service* manual, then these publications have precedence.

2 Definitions

Company – Public Service Electric and Gas (**PSE&G**)

Customer – The entity requesting service.

High-Rise Building – A building 500 ft or more in height above grade.

Tariff – BPUNJ No. 15 Electric; Tariff for Electric Service (https://www.pseg.com/family/pseandg/tariffs/electric/pdf/electric_tariff.pdf).

Transformer Manhole – A typical Company vault as specified in the *Underground Construction Outside Plant Manual*.

Interior Transformer Vault – A transformer vault room built to Company specifications at grade, behind the property line. The size depends on the number of transformers.

High Voltage Secondary – 480 V secondary.

Load Disconnect Switch – A 480 V switch designed to energize or de-energize sections of 480 V cables.

Below Grade – anywhere below the grade level of the building entrance.

Internal Distribution System – A customer designed, built, and maintained system to supply 120/208 V. The internal distribution system contains high voltage secondary for distribution, and 480Y/277 to 208Y/120 transformers to provide 208/120 V. The design must be accepted by the Company before construction.

3 General Specification

The general specification provides the initial Customer requirements necessary to design the service.

3.1 Initial Customer Requirements

The Customer shall provide the Company with the following information:

1. Connected load
2. Building square footage
3. Building height
4. Type of customer served (residential, commercial, industrial, or mixed use)
5. One line diagram of the internal distribution system

The information shall be provided in the form of drawings, sketches and load letters, signed and approved by the Customer or Customer's consultants. Provide three copies of each.

The Customer shall respond to the Company correspondence and comments within 2 weeks.

3.2 Initial Company Response

The Company shall:

1. Review the customer's requirements.
2. Determine the number and size of transformers.
3. Determine the vault and bus room specifications and requirements.
4. Provide the customer with the latest online version of the *Information and Requirements for Electric Service*.
5. Provide a proposed project specific service layout.
6. The Company shall respond to the customer with comments via e-mail and certified mail in 4 weeks.

4 Types of Service

The type of service and the design recommended by the Company depends on the load and, the height and planned usage of the building. If the Customer desires a different type of service that is within the tariff and approved by the Company, then the Customer shall pay the difference in costs to the Company.

4.1 High-Rise Residential Service

A High-Rise Residential Customer must comply with the *National Electrical Code (NEC)*, the *National Electrical Safety Code (NESC)*, the local Authority having Jurisdiction, and the applicable sections of the latest *Information and Requirements for Electric Service* manual.

Residential buildings eligible for standard spot network service, but above 500 ft in height, are required to have high-rise residential service. This requires a standard spot network service to supply the lower floors, a 480 V service to supply 480 V load, and service to the upper floors (500 ft or higher) via a Customer-designed and built internal distribution system supplied with 480/277 V that steps the voltage down to 208/120 V or a variation thereof acceptable to the Company. The customer may propose distributing 480 V to

nearby adjacent floors for consideration by PSE&G; PSE&G will have final discretion. The residents are metered using Company meters. See a typical design in [Figure 11.1](#). The customer shall provide plans to distribute 208/120 V to the lower and upper floors. The Company shall provide the site specific design after reviewing the Customer requirements.

4.1.1 Additional Customer Requirements for High-Rise Residential Service

The Customer shall:

- Provide space for the Company specified network transformer vaults and bus rooms for 208Y/120 or 480Y/277 V.
- Purchase 480Y/277 to 208Y/120 step down transformers.
- Provide conduits or raceways for sets of 600 V cable/bus from the lower 480 V bus room to the Customer designed internal distribution system. The impedance per 1000 ft of the cable or bus duct shall be $0.0027+0.0016j$ ohms or less.
- Install and maintain Company specified standard bus rooms at or below grade.
- Design and build an internal distribution system.
- Purchase, own and maintain Company specified metering. See the *Information and Requirements for Electric Service* for details.

Note

The 480 V bus duct/cable supplying 480Y/277 to 208Y/120 step down transformers shall not be tapped to supply other 480/277 V load.



The Company shall:

- Install and maintain standard 208Y/120 V or 480Y/277 V network transformers, network protectors and secondary cable, and limiters at or below grade.
- Review and accept the 208/120 V internal distribution system.

Note

The Customer is required to build vaults and install equipment at or above grade on Customer property. The requirements are similar to those in [Section 4.1](#)



4.2 Primary Service

Commercial, condominium and industrial facilities with loads specified in [Table 2-2](#) of the latest online version of the *Information and Requirements for Electric Service* manual are eligible for primary service. A high tension customer must comply with the NEC, the NESC, the local Authority Having Jurisdiction, and the applicable sections of the latest *Information and Requirements for Electric Service* manual.

The interior electrical design must be accepted by the Company.

Note

Metering must be in compliance with New Jersey Administrative Code (**N.J.A.C.**) which currently does not permit electric sub-metering for residential rental units. See Tariff Section 9.2.2 Sub-Metering for further details.



5 General Specification Certification

I certify that two (2) copies of the General Specification for High-Rise Service and one (1) copy of the specifications applicable to my service were received.

Name

Company

_____ Title

_____ Date

The customer shall sign both copies of the General Specification for High-Rise Service and return one to the Company.

6 Site Specific Specification

The site specific specification is a signed agreement that contains:

1. A number based on the year, division, DWMS number, and supervisor's initials.
2. The final design for the service.
3. Customer requirements.
4. Company requirements.
5. The signatures of the Company and the customer.

The customer must comply with the "initial customer requirements" in [Section 3.2](#) of the general specification and return a signed copy of the general specification before a site specific specification is written.

7 Service Sketch

The Company shall forward a marked up site plan for the site specific service layout.

8 Customer Requirements

The customer shall:

1. Provide space for the Company specified transformer vaults and bus rooms for 208Y/120 or 480Y/277 V.
2. Install and maintain a Company specified standard bus room to Company specifications.
3. Purchase, own and maintain stack metering as per Company specifications. Consult the PSE&G wiring inspector for details.

4. Design, build and maintain an internal distribution system.
5. Provide a one line diagram of the site specific, Customer-installed internal distribution system. See [Figure 11.1](#).

9 Company Requirements

The Company shall:

1. Install and maintain standard 208Y/120 V or 480Y/277 V network transformers, network protectors, secondary cable, and limiters.
2. Review and accept the 208/120 V internal distribution system.
3. Provide metering to the customer for installation.

10 Site Specific Certification

The Company and the Customer agree to the terms and agreements in Site Specific Specification 2015 M "DWMS Number"-XX.

The Distribution Manager of Engineering & Resources from the division where the customer's premises are located must sign two copies of the document and forward them to the customer.

Name
PSE&G _____ Division

Title _____ Date _____

Name _____

Company _____

Title _____ Date _____

The Customer shall sign both copies of the Site Specific Specification for High-Rise Service and return one to the Company.

Figure 11.1: Example of One Line Diagram

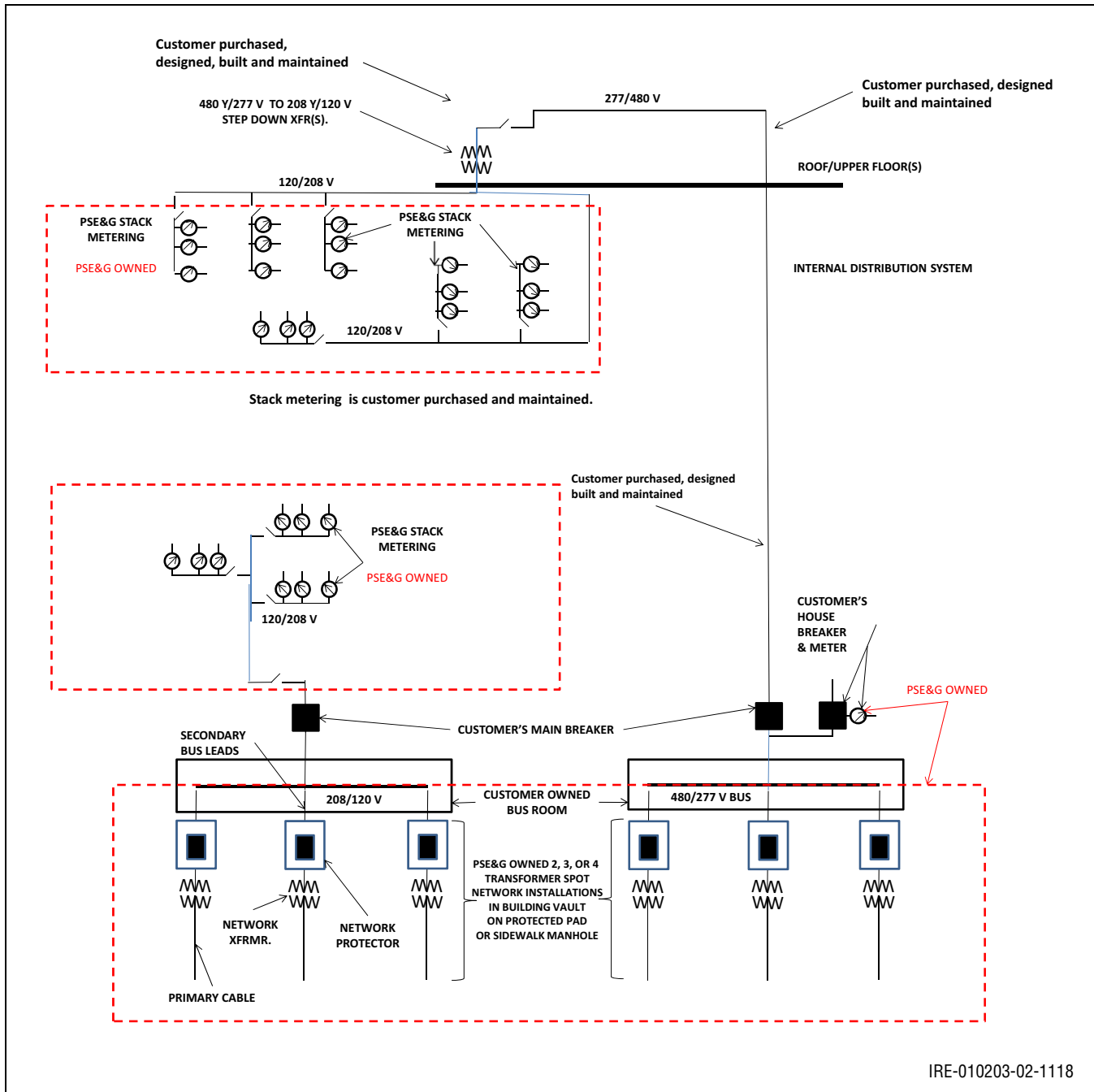

Note This one line diagram is a sample and may not reflect site specific information for the customer.



Stack metering is purchased, owned and maintained by the customer and shall meet Company specifications. Consult the PSE&G wiring inspector for details.

Forms

This chapter provides a list of forms used in the *Information and Requirements for Electric Service* manual and links to those forms in PDF format. This fillable PDF can be completed and saved. In addition, the pages following this list contain forms that can be printed for hardcopy use.

[ED-DC-IRE-Form001](#) – Temporary Electric Service(s) Application (for a fillable form click [here](#))

[ED-DC-IRE-Form002](#) – Permanent Electric Service(s) Load Information (for a fillable form click [here](#))

[ED-DC-IRE-Form003](#) – Commercial/Industrial Project Contact Information Sheet (for a fillable form click [here](#))

[ED-DC-IRE-Form004](#) – Residential Project Contact Information Sheet (for a fillable form click [here](#))

[ED-DC-IRE-Form005](#) – Motor Data Sheet – 100 Horsepower and Above (for a fillable form click [here](#))

[ED-DC-IRE-Form006](#) – Resistance Welder Data Sheet (for a fillable form click [here](#))

[ED-DC-IRE-Form007](#) – Power Quality Data Sheet (for a fillable form click [here](#))

[ED-DC-IRE-Form008](#) – Service Removal Request Application (Demolition) (for a fillable form click [here](#))

This Page Intentionally Blank



Temporary Electric Service(s) Application

Name: _____

Location Address: _____

Town: _____

Phone No.: _____ Fax No.: _____

Email: _____

Electrician's Name: _____

Electrician's Phone No.: _____ Electrician's Fax No.: _____

Date Required: _____ Duration Temporary Power Needed: _____

Nearest Pole No.: _____ Nearest Pad No.: _____

Appliance Type	Single-Phase kW	Three-Phase kW	Number of Units	Total kW of Each Appliance by Type
Lighting				
Power Supply				
Air Conditioning				
Welder				
Motor(s) Pump(s) (Plus HP Rating)				
Elevators				
Miscellaneous				
Total kW Columns in this Row				

Service Voltage Characteristics

Service Amperage Size

Permanent Electric Service(s) Load Information

Electric load information must be listed in kW for any and all new equipment to be installed by each appliance individually, then multiplied by the number of units and totaled in the far-right column. The electric service amperage size and voltage characteristics must be stipulated at the bottom of the page. When a miscellaneous load is listed, a description of its purpose must be supplied.

Appliance Type	Single-Phase kW	Three-Phase kW	Number of Units	Total kW of Each Appliance by Type
Interior Lighting				
Exterior Lighting				
Air Conditioning				
Heat Pumps				
Comfort Heating				
Water Heating				
Cooking				
Receptacles				
Motor(s) Pump(s) (Plus H P Rating)				
Fan(s)				
Refrigeration				
Elevators				
Computer				
Miscellaneous				
House Load				
Total kW Columns in this Row				

Service Voltage Characteristics

Service Amperage Size

Square Footage of Units

Total Square Footage of Premise

Air Conditioning Size in Tons

Commercial/Industrial Project Contact Information Sheet

Builder/Developer Company Name: _____

Builder/Developer Contact Name: _____

Mailing Address: _____

Phone No.: _____ Fax No.: _____

Cell No.: _____ Email: _____

Square Feet of Building(s): _____ Construction Start Date: _____

Building Location Description: _____

SIC Code: _____ Number of Units or Bays: _____

Number of Electric Meters: _____ Number of Common Area Meters: _____

Number of Gas Meters: _____ Number of Common Area Meters: _____

Electrical Contractor: _____

Address: _____

Phone No.: _____ Fax No.: _____

Cell No.: _____ Pager No.: _____

Email: _____

Mechanical Contractor (Plumber): _____

Address: _____

Phone No.: _____ Fax No.: _____

Cell No.: _____ Pager No.: _____

Email: _____



Residential Project Contact Information Sheet

Company Name: _____

Project Name: _____

Project Contact Person: _____

Mailing Address: _____

Phone No.: _____ Fax No.: _____

Cell No.: _____ Email: _____

Number of Buildings if Condo or Town Homes: _____

Number of Units or Apartments if Condo or Town Homes: _____

Number of Single Family Homes: _____

Construction Start Date: _____ Active Service Date: _____

Site Contact Name: _____

Address: _____

Phone No.: _____ Fax No.: _____

Cell No.: _____ Pager No.: _____

Email: _____

Electrical Contractor: _____

Address: _____

Phone No.: _____ Fax No.: _____

Cell No.: _____ Pager No.: _____

Email: _____

Mechanical Contractor (Plumber): _____

Address: _____

Phone No.: _____ Fax No.: _____

Cell No.: _____ Pager No.: _____

Email: _____

Motor Data Sheet – 100 Horsepower and Above**Manufacturer's Motor Data**

Manufacturer's Name: _____

Type (Squirrel Cage, Wound Rotor, Synchronous): _____

No. of Phases: _____ NEMA Code Letter: _____

Rated Voltage: _____ Rated Amperage: _____

Rated HP: _____ Power Factor: _____

Locked Rotor (Amps, kVA, or HP): _____

Power Factor at Starting: _____

Motor Operating Data

Desired Starting Frequency: _____ Number of Motor Starts Per Day: _____

Starting Devices:

Description of any external means of limiting the starting inrush current the customer may plan to employ (e.g. Auto Transformer).

Unusual Operating Characteristics:

Description of any unusual conditions, such as fluctuations from no load to full load while running, and the diversified loads and power factors for these conditions.

Resistance Welder Data Sheet**Manufacturer's Welder Data**

Rated kVA – 50% Duty Cycle: _____

Power Factor Percentage: _____

Welder Primary Voltage: _____ Phase Type: _____

Maximum Open Short Circuit Secondary Voltage: _____

Maximum Short Circuit Secondary Current: _____

Number of Welds Per Minute: _____

Welder Type: Spot Seam Projection Flash Other

Remarks:

DWMS Number: _____

Project/Service Consultant Name: _____

Date: _____

Power Quality Data Sheet

Customer Name: _____ Date: _____

Service Address: _____

Project/Service Consultant Name: _____

Proposed Service DWMS No.: _____

Voltage: _____ Amperage: _____

Customer's Sensitive Equipment

PCs LAN Connected: Yes No

Equipment Type	Quantity	Total kVA
PCs		
Three-Phase Computers		
Adjustable Drive		
Programmable Logic Control		
Robotics		
Telecommunications Equipment		
Other		
Other		
Other		

Sensitive Processes (check all that apply)

 Data Processing

 Data Transmission

 Telecommunications

 Production

 Testing – R&D

 Other

Proposed Mitigation Equipment

Surge Suppression

Panel Mounted No.: _____

Plug In and Other No.: _____

Equipment	Quantity	kVA
Single-Phase UPS/SPS		
Three-Phase UPS		
Line Conditioners		
Generators		
Other (Describe)		

Data Supplied by:

Name: _____ Title: _____ Phone No.: _____

E-mail Address: _____

Customer Contact(s):

Name: _____ Title: _____ Phone No.: _____

Name: _____ Title: _____ Phone No.: _____

E-Mail Address: _____

Customer Electrical Consultant(s):

Name: _____ Firm: _____ Phone No.: _____

Name: _____ Firm: _____ Phone No.: _____

Remarks:



Public Service Electric & Gas Company
P.O. Box 790, Cranford, NJ 07016-0790
Phone: 800-817-3366 Fax: 908-497-1878
E-mail: demolition@pseg.com

For Office Use Only	
Project No.:	_____
E1 No.:	_____
G1 No.:	_____

Service Removal Request Application

Write clearly and review application instructions before completing this form.

Owner's Name: _____ Date: _____

Owner's Authorized Agent: _____

Premises Vacant? Yes No

Service Address: _____
(of building to be Demolished)

Mailing Address: _____

Cross Street: _____

Owner's Primary Residence? Yes No

Important: Application Will Not Be Accepted Until Applicant Has Taken Ownership and Property Is Vacant.

Project Contact: _____ Fax No.: _____

Primary Phone No.: _____ Alternate Phone No.: _____

E-mail Address: _____

Meter Numbers: Gas _____ Electric _____

Type and Number of Structures to be Demolished: _____

PSE&G Lighting to be Removed: Yes No

Other PSE&G Equipment (Poles, Transformers, Etc.)? _____

Type of Electrical Service: Overhead Underground

Type of Structure to be Built after Demolition: _____

Approximate Date of Reconstruction: _____

Signature: _____ Print Name: _____

By submitting this application, you are certifying that you are authorized to request removal of electric and gas services at the property specified above, and that the premises are vacant.

Index

A

Aggregate Net Metering	9-1
American National Standards Institute	1-1
Architects	1-1, 1-10
Area Network	9-11

B

BPU	1-1, 1-3
BUD	1-3, 1-5, 1-8, 3-6, 3-8, 4-4, 10-15
Buried Underground Distribution	1-3, 1-5, 3-6

C

Cables and conduit	3-1
CATV	6-9, 10-3, 10-78, 10-79, 10-80, 10-81
Check Metering	5-5
Conduit and cable	4-3
Contractors	1-1, 1-8, 1-9, 1-10
Control cable	5-3, 10-41, 10-42
Customer's premises	1-3, 1-7, 1-11, 3-8
Customer-generator	9-7, 9-10
Customer-Generator Facility	9-1
Customers	1-1, 1-2, 1-3, 1-4, 1-6, 1-8, 1-10, 1-11, 2-1, 2-2, 2-5, 4-1, 4-6, 4-7, 5-1, 5-2, 5-4, 6-1, 6-4, 6-7, 6-8, 10-20, 11-1, 11-2

D

Department of Transportation	6-8
DOT	2-2, 6-8

E

E1 Notification	9-1
Energy evaluation services	6-8
Engineers	1-1, 1-10
ESOC	9-1
Extension	1-3, 1-12, 1-13

F

Feasibility Study Charge 2-1, 2-4, 2-5

H

High-Rise Buildings 11-1
 High-Rise Service 11-4, 11-5

I

IEEE 9-6, 9-13
 IEEE 1547 9-1
 Interconnection Application and Agreement 9-2
 Interconnection Point 9-2

M

Major electrical equipment 4-6, 4-7
 Metal Enclosed Switchgear 1-4, 1-7
 Meter mounting 1-5, 1-10, 4-6, 5-3, 10-7, 10-45
 Metering and Inspection Department 9-5

N

National Electrical Code 1-1, 1-2, 1-8, 2-2, 3-5, 3-10, 4-1, 4-2, 4-3, 6-1, 6-3, 6-4, 6-6, 6-7, 9-7, 10-1, 10-6, 10-7,
 10-10, 10-11, 10-22, 10-24, 10-26, 10-28, 10-37, 10-39, 10-41, 10-43, 10-45, 10-58,
 10-66, 10-69, 10-77, 11-2, 11-3
 National Electrical Manufacturers Association 1-1, 6-7
 National Electrical Safety Code 1-1, 1-2, 3-2, 4-1, 4-2, 6-1, 6-3, 6-4, 9-7, 10-1, 11-2, 11-3
 Net Metering 4-1, 6-5, 9-2, 9-6, 10-84
 Network Distribution Systems 9-10
 Network Protection Relay 9-13
 New Jersey Administrative Code 9-3, 11-3
 New Jersey Board of Public Utilities 1-1, 1-3, 1-6, 1-8
 NJ Clean Energy Program 9-7
 Non-Utility Generator (NUG) 9-2

O

Office Buildings 5-4
 Overhead primary service 3-7

Overhead secondary service 1-4, 3-4, 4-3, 10-5, 10-9

P

Padmounted transformer installations 3-8, 10-49, 10-54

PJM 9-2

Power factor 6-1, 6-5

Primary distribution 3-1

Primary Service 1-5, 4-6, 11-3

Primary system 2-3

R

Real estate developments 2-2

Regulation for Residential Electric Underground Extensions 1-3, 1-7, 3-6

Renewable Energy 9-2

Renewable Generation 9-10

Residential unit buildings 5-4

S

Secondary Service 1-5, 2-3, 3-5, 3-6, 3-9, 4-2, 4-3, 4-4, 4-6, 6-3, 10-17, 10-40, 10-58

Service characteristics 1-1, 2-1

Service Consultant 1-1, 1-7, 1-10, 3-1, 5-4, 6-1, 6-6, 6-8

Single-phasing 2-1, 6-4

Solar installations 9-15

Solar System 9-12, 9-13, 9-14, 9-15

Spot Network 9-11

Standardized Interconnection Requirements 9-3

Submetering 5-5

Subtransmission System 2-3, 10-20

T

Tariff for Electric Service 1-1, 1-8, 1-10, 2-1, 11-1

Test switches 4-1, 5-3

Types of services 2-2, 4-6

U

Underground primary service 3-7

Underground secondary service1-5, 3-5
Underground zone3-6, 3-7, 3-8, 3-9
Undervoltage (low-voltage) protection 6-4

W

Wiring Inspector 3-1