

# Subregional RTEP Committee – Western FirstEnergy Supplemental Projects

April 25, 2023



# Submission of Supplemental Projects for Inclusion in the Local Plan



**Need Number:** ATSI-2019-083

**Process Stage:** Submission of Supplemental Project for Inclusion in the Local Plan - 4/25/2023

**Previously Presented:** Need Meeting – 11/22/2019  
Solutions Meeting – 02/21/2020

**Supplemental Project Driver(s):**  
*Customer Service*

**Specific Assumption Reference(s)**

Modification of existing customer connection request evaluated per FirstEnergy’s “Requirements for Transmission Connected Facilities” document and “Transmission Planning Criteria” document.

**Problem Statement**

Existing Customer Connection – Service Modification

- The existing customer requested modification to their current 138 kV transmission service.
- The request is to move some of their existing load from the Harding – Jennings Q13 138 kV line to the Harding – Jennings Q11 138 kV line.

This request is not for a load increase but will result in a system topology change.

SRRTEP Committee: Western – FirstEnergy Supplemental

ATSI Transmission Zone M-3 Process  
LTV East Steel Customer- Solution

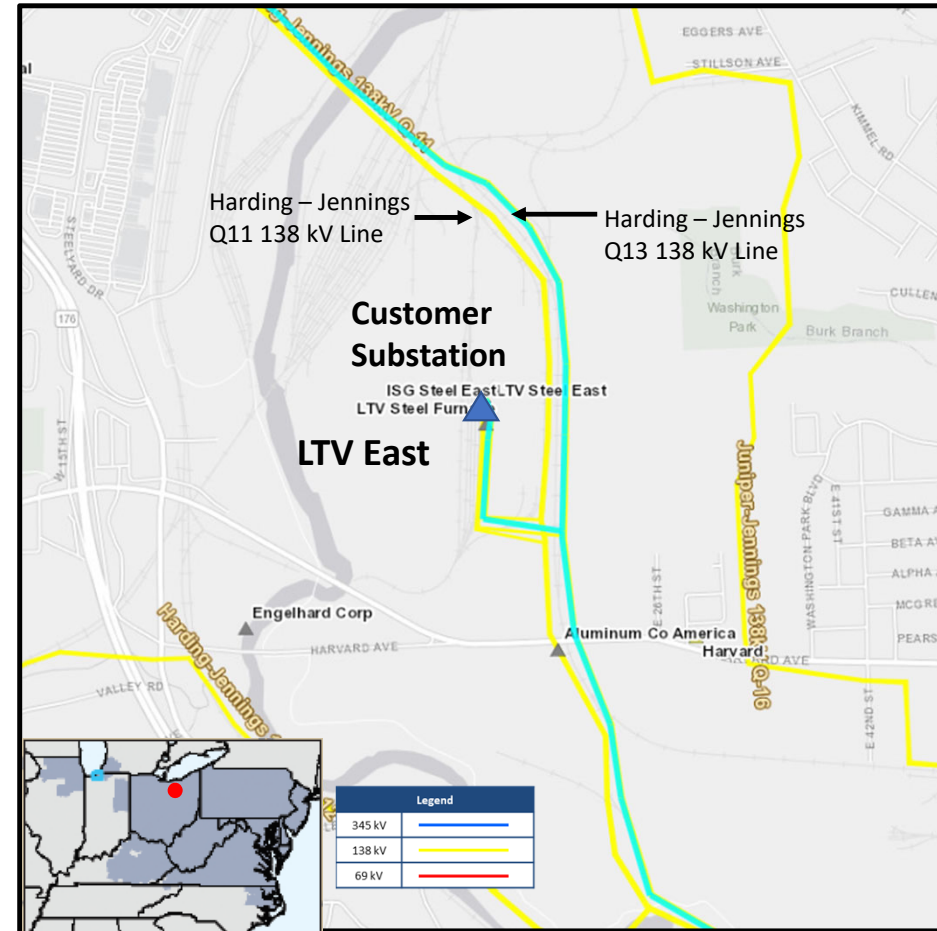



**Need Number:** ATSI-2019-083

**Process Stage:** Submission of Supplemental Project for Inclusion in the Local Plan - 4/25/2023

**Previously Presented:** Need Meeting – 11/22/2019  
Solutions Meeting – 02/21/2020

**Selected Solution:**

- Disconnect transformer #2 from the Harding – Jennings Q13 138 kV line.
- Reconnect transformer #2 to the Harding – Jennings Q11 138 kV line.

**Estimated Project Cost:** \$0.130 M

**Projected In-Service:** 03/15/2020

**Supplemental Project ID:** s2183

## ATSI Transmission Zone M-3 Process LTV East Steel Customer- Solution

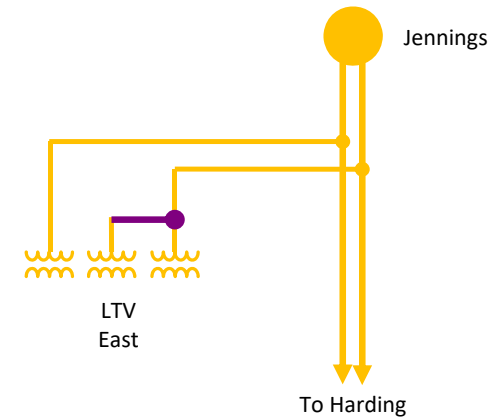

Legend	
500 kV	
345 kV	
138 kV	
69 kV	
34.5 kV	
23 kV	
New	





**Need Number:** ATSI-2022-011  
**Process Stage:** Submission of Supplemental Project for Inclusion in the Local Plan – 04/25/2023  
**Previously Presented:** Need Meeting – 05/19/2022  
 Solutions Meeting – 10/14/2022

**Supplemental Project Driver(s):**  
*Operational Flexibility and Efficiency*  
*Equipment Material Condition, Performance and Risk*  
*Infrastructure Resilience*

**Specific Assumption Reference(s):**

**Global Considerations**

- System reliability and performance
- Substation / line equipment limits

**Upgrade Relay Schemes**

- Relay schemes that have a history of misoperation
- Obsolete and difficult to repair communication equipment (DTT, Blocking, etc.)
- Communication technology upgrades
- Bus protection schemes

**Problem Statement**

- FirstEnergy has identified protection schemes using a certain vintage of relays and communication equipment that have a history of misoperation.
- Proper operation of the protection scheme requires all the separate components perform adequately during a fault
- In many cases the protection equipment cannot be repaired due to a lack of replacement parts and available expertise in the outdated technology.
- Transmission line ratings are limited by terminal equipment

Continued on next page...

SRRTEP Committee: Western – FirstEnergy Supplemental

## ATSI Transmission Zone M-3 Process Firestone-South Akron 138 kV Line Solution

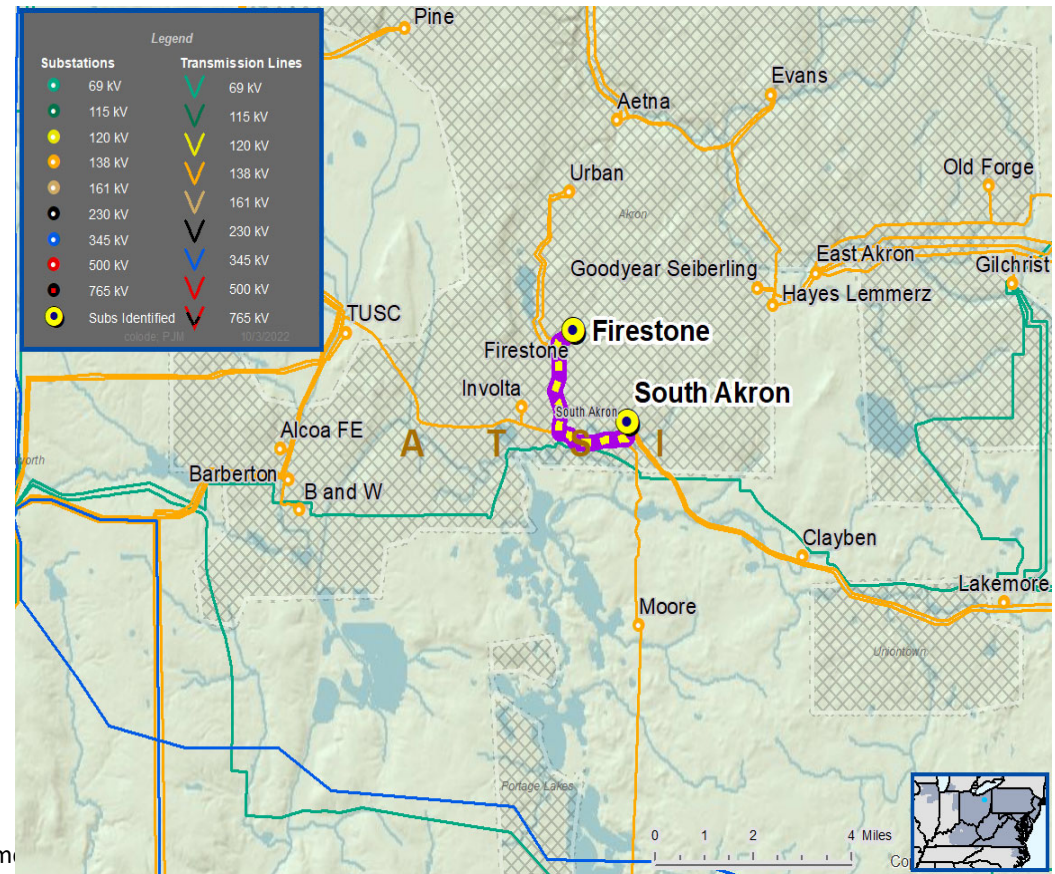



## ATSI Transmission Zone M-3 Process Firestone-South Akron 138 kV Line Solution

...Continued from previous page

Need Number	Transmission Line / Substation Locations	Existing Line / Terminal Equipment MVA Rating (SN / SE)	Existing Conductor / Transformer MVA Rating (SN / SE)	Limiting Terminal Equipment
ATSI-2022-011	Firestone-South Akron 138 kV Line	195/209	233/282	Wavetrap, relay, and substation conductor



**Need Number:** ATSI-2022-011  
**Process Stage:** Submission of Supplemental Project for Inclusion in the Local Plan - 4/25/2023  
**Previously Presented:** Need Meeting – 05/19/2022  
 Solutions Meeting – 10/14/2022

**Selected Solution:**

- At Firestone Substation – replace wave traps, line CCVTs, line and breaker failure relays, carrier sets, and line tuners for the South Akron 138 kV line exit
- At South Akron Substation – replace wave traps, line drops, line CCVTs, line and breaker failure relays, carrier sets, and line tuners for the Firestone 138 kV line exit

**Transmission Line Ratings:**

- Firestone-South Akron 138 kV Line
  - Before Proposed Solution: 195 MVA SN / 209 MVA SE, 210 MVA WN / 210 MVA WE
  - After Proposed Solution: 221 MVA SN / 262 MVA SE, 263 MVA WN / 300 MVA WE
- Maintain existing condition and risk of failure.

**Estimated Project Cost:** \$2.2 M

**Projected IS Date:** 06/01/2023

**Supplemental Project ID:** s2859

## ATSI Transmission Zone M-3 Process Firestone-South Akron 138 kV Line Solution



Legend	
500 kV	
345 kV	
138 kV	
69 kV	
34.5 kV	
23 kV	
New	



## ATSI Transmission Zone M-3 Process Cuyahoga Falls 138 kV Planning Area- Solution

**Need Number:** ATSI-2019-010 (s2387)  
**Process Stage:** Submission of Supplemental Project for Inclusion in the Local Plan – 04/25/2023  
**Previously Presented:** Need Meeting – 01/11/2019  
Solutions Meeting – 11/22/2019  
Re-Present Solutions Meeting – 10/14/2022

**Supplemental Project Driver(s):**  
*Operational Flexibility and Efficiency*  
*Infrastructure Resilience*

### Specific Assumption Reference(s)

Global Considerations

- System reliability and performance
- Substation / Line equipment limits
- Reliability of Non-Bulk Electric System (Non-BES) facilities
- Load and risk in planning and operational scenarios
- Load and/or customers at risk on single transmission line

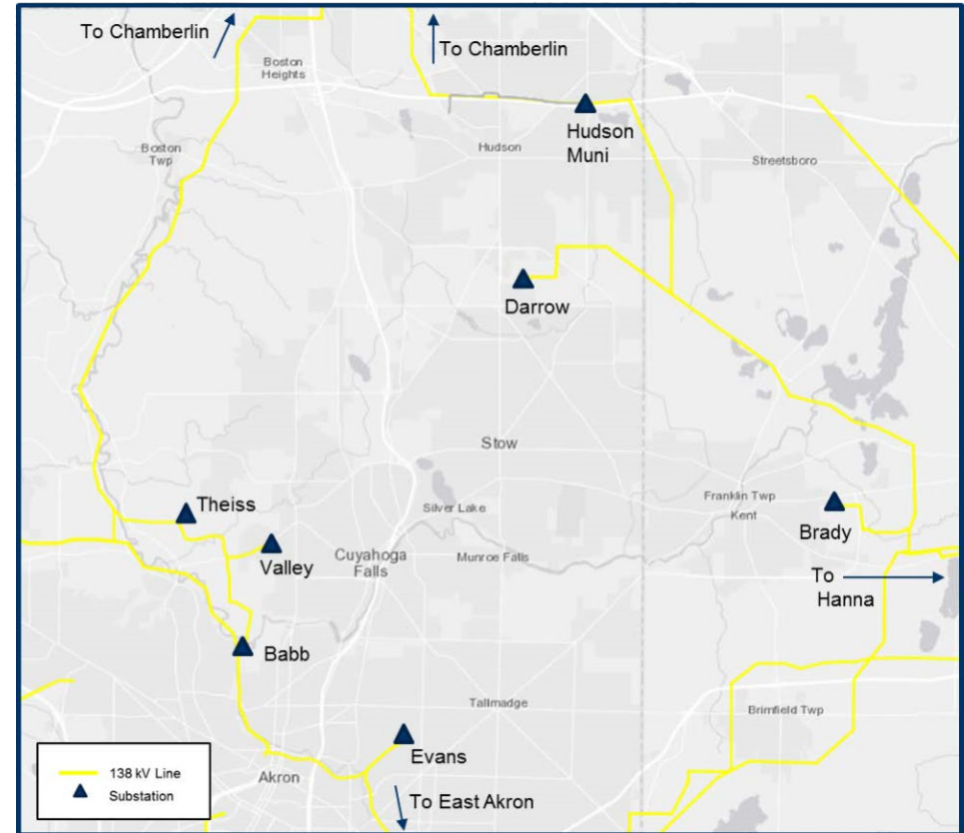





## ATSI Transmission Zone M-3 Process Cuyahoga Falls 138 kV Planning Area- Solution

**Need Number:** ATSI-2019-010 (s2387)  
**Process Stage:** Submission of Supplemental Project for Inclusion in the Local Plan - 4/25/2023

**Problem Statement**

**Valley & Thiess 138 kV Substation Area**

The Valley and Thiess 138 kV substations are presently co-owned by FE and Cuyahoga Falls Municipality with transmission service from the ATSI Babb-Chamberlin 138 kV line.

- A transmission line outage of the double circuit networked 138 kV tap (approximately 1 mile) to Valley substation could result in approximately 86 MW and 25,000 Customers interrupted for an extended period of time.
- The loss of the Chamberlin-Thiess 138 kV line, followed by the loss of the Babb-Valley 138 kV line (N-1-1) could result in approximately 106 MW and 25,000 customers interrupted for an extended period of time.

**Evans & Darrow 138 kV Substation Area**

- The loss of the Babb-Evans 138 kV line, followed by the loss of the East Akron-Evans 138 kV line (N-1-1) results in approximately 25 MW and 4,834 customers interrupted.
- The loss of the Chamberlin-Hudson Muni 138 kV line, followed by the loss of the Brady-Hanna 138 kV line (N-1-1), results in approximately 61 MW and 18,800 customers interrupted. Post-contingency voltage drops below 0.92 p.u. in the Darrow substation area.

**System Performance**

Over the past five years:

- The Chamberlin-Thiess 138 kV line has experienced one (1) outage (1 sustained, 0 momentary)
- The Thiess-Valley 138 kV line has experienced two(2) outages (2 sustained, 0 momentary)
- The Chamberlin-Hudson Muni 138 kV line has experienced three (3) outages (2 sustained, 1 momentary)
- The Babb-Evans 138 kV line has experienced one (1) outage (0 sustained, 1 momentary)
- The Babb-Valley 138 kV line has experienced one (1) outage ( 1 sustained, 0 momentary)

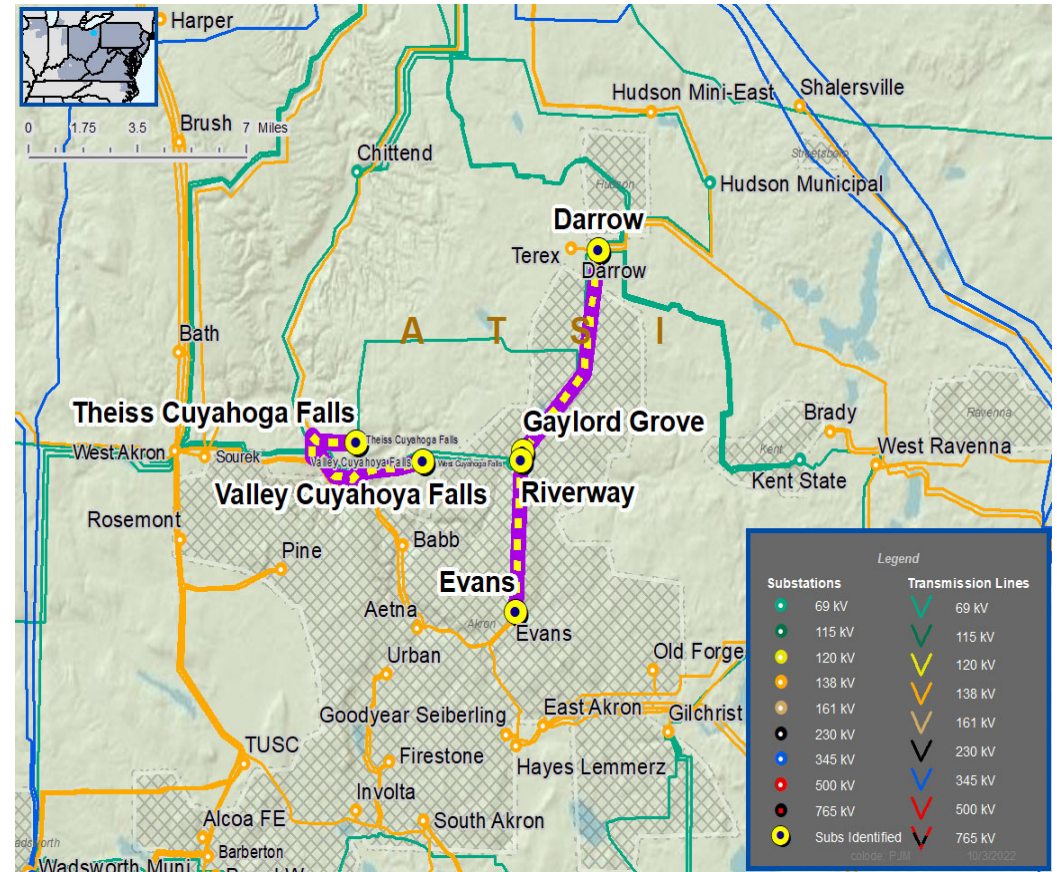



**Need Number:** ATSI-2019-010 (s2387)  
**Process Stage:** Submission of Supplemental Project for Inclusion in the Local Plan - 4/25/2023

**Selected Solution:**

**FE Identified Scope (\$36.3M):**

*New 138 kV Line & Sub 5 Expansion*

- Build FE Sub 5 (Riverway) 138 kV four (4) breaker ring bus adjacent to the AMPT Gaylord Grove substation
- Convert Evans 138 kV substation into five (future 6) breaker ring bus
- Convert the proposed Darrow five (future 6) breaker ring bus (s1708) into six breaker ring bus
- Build a new 138 kV line from Evans to new FE Sub5 ( Approximately 4.4 miles)
- Build a new 138 kV line from Darrow to new FE Sub5 ( Approximately 6.6 miles)
- Add a 28 MVAR 138 kV capacitor bank at Theiss substation.

**AMPT Identified Scope (\$29.0M):**

- At Valley 138/23.8 kV Substation - Install two (2) 138 kV CBs and associated equipment to separate AMPT’s 138 kV facilities from FE’s 138 kV ring bus. Relocate two (2) existing 138/23.8 kV transformers to accommodate the new 138 kV CBs. Install new panels in a new AMPT control house. **(\$6.3 M)**
- Construct a greenfield 138/69/23 kV station called “Gaylord Grove”, located next to FE’s proposed Riverway 138 kV station and Cuyahoga Falls existing Substation 5. Install two (2) 138/69 kV 170 MVA transformers, two (2) 138 kV CBs, five (5) 69 kV CBs using 69 kV bus rated to 2000A. **(\$22.7 M)**

**Cuyahoga Falls Scope (\$0.0 M)**

- Install two (2) 69/23 kV transformers, two (2) 23 kV low side transformer CBs and other associated equipment to connect from Gaylord Grove 69 kV yard to Cuyahoga Falls’ Substation 5 23 kV station. *These facilities are distribution and not included in the overall project costs.*

**Total Estimated Project Cost: 65.3M**

## ATSI Transmission Zone M-3 Process Cuyahoga Falls 138 kV Planning Area- Solution

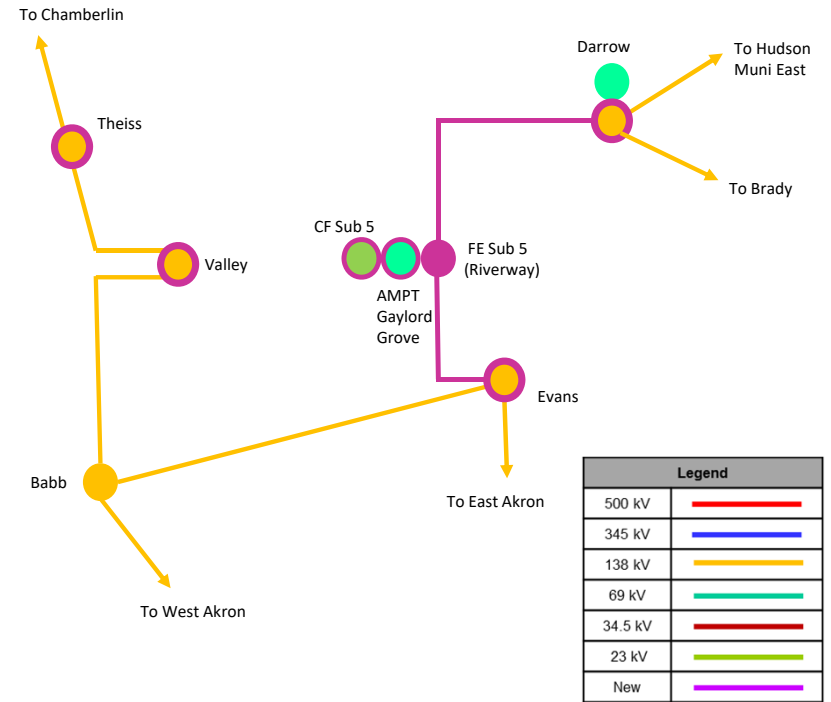



**Need Number:** ATSI-2019-010 (s2387)  
**Process Stage:** Submission of Supplemental Project for Inclusion in the Local Plan - 4/25/2023

- Transmission Line Ratings:**
- Darrow-FE Sub 5 138 kV Line
    - After Proposed Solution: 278 MVA SN / 339 MVA SE
  - Evans-FE Sub 5 138 kV Line
    - After Proposed Solution: 278 MVA SN / 339 MVA SE

**Projected In-Service:** 06/01/2025  
**Supplemental Project ID:** s2387  
**Model:** 2018 Series 2023 Summer RTEP 50/50

## ATSI Transmission Zone M-3 Process Cuyahoga Falls 138 kV Planning Area- Solution

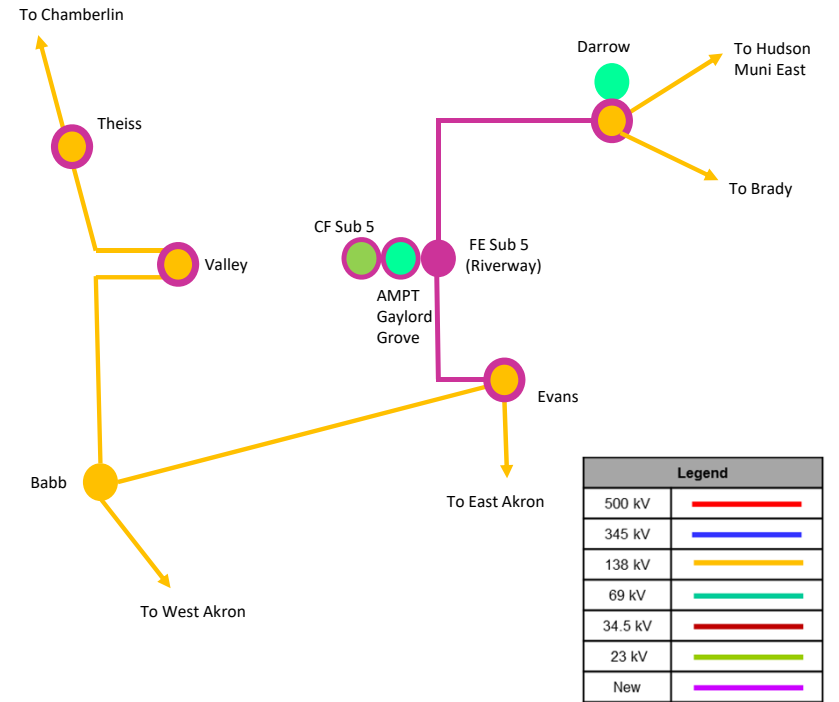



**Need Number:** ATSI-2022-014  
**Process Stage:** Submission of Supplemental Project for Inclusion in the Local Plan – 04/25/2023  
**Previously Presented:** Need Meeting – 06/15/2022  
 Solution Meeting – 11/18/2022

**Supplemental Project Driver(s):**  
*Equipment Material Condition, Performance, and Risk Infrastructure Resilience*

**Specific Assumption Reference(s):**

**Global Factors**

- System Reliability and Performance
- Increasing negative trend in maintenance findings
- Age/condition of transmission line conductor, hardware and structures
- Negatively impact customer outage frequency and/or duration

**Problem Statement**

- A common structure outage of the 69 kV line section (Shinrock-Oberlin & Henrietta-Oberlin 69 kV Line, approx. 1.6 miles) will result in a power outage of the Oberlin Muni substation impacting approximately 3,100 customers, 22 MW of load, and 19.2 MW of wholesale generation.
- A maintenance outage of the double circuit section of the 69 kV line (Shinrock-Oberlin & Henrietta-Oberlin 69 kV Line) will require an outage of the Oberlin Muni substation impacting approximately 3,100 customers, 22 MW of load, and 19.2 MW of wholesale generation.
- In 2021, the Oberlin Muni delivery point was outaged two times to address emergency repairs on the double circuit portion of the line (approx. 2-3 hours each outage).

## ATSI Transmission Zone M-3 Process Shinrock-Oberlin-Henrietta 69 kV Line Solution

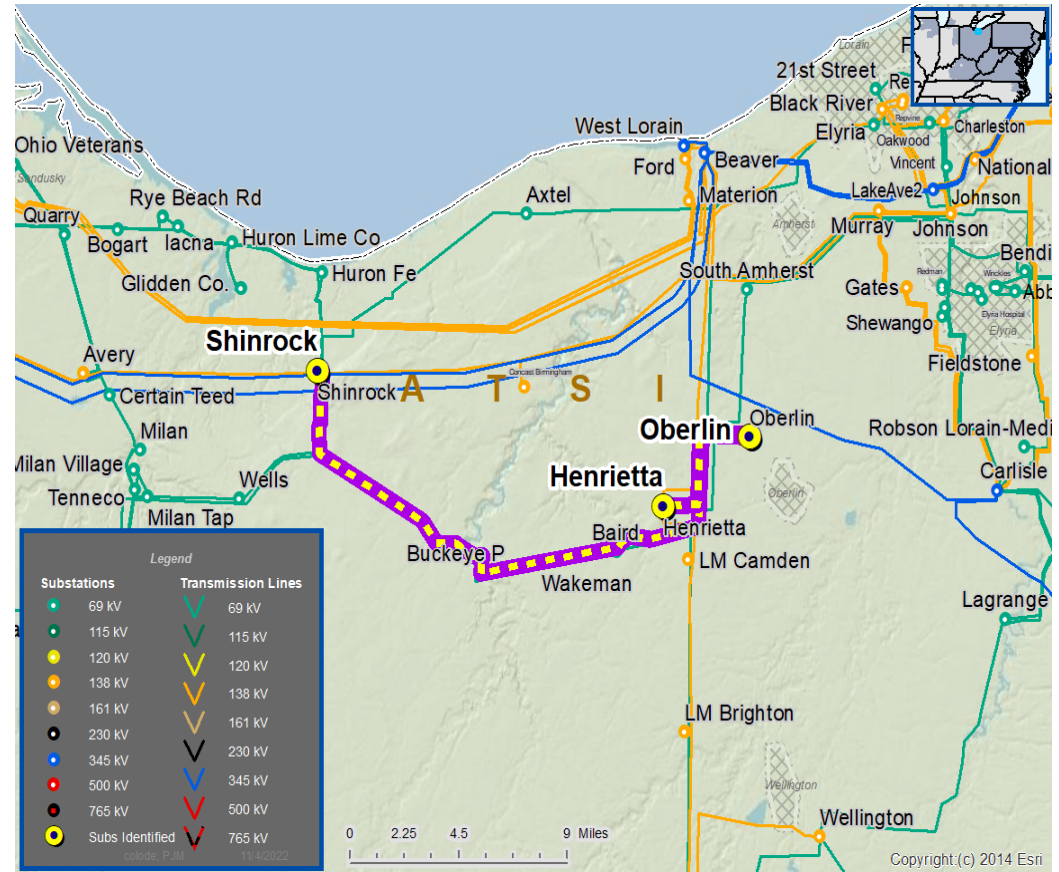

Continued on next page...





**Need Number:** ATSI-2022-014  
**Process Stage:** Submission of Supplemental Project for Inclusion in the Local Plan – 04/25/2023  
**Previously Presented:** Need Meeting – 06/15/2022  
 Solution Meeting – 11/18/2022

**Problem Statement**

- A ground and aerial CVI inspection conducted in 2021 identified:
  - 18 of the 27 common structures on the 69 kV line section (Shinrock-Oberlin & Henrietta-Oberlin 69 kV Line) have defects including rotten and /or cracked wood poles, cracked crossarms and crossarm braces, woodpecker damage and worn static wire attachments
  - The Shinrock-Oberlin-Henrietta 69 kV Line (approx. 26 miles, excluding the common structure portion of the line), has a 25% defect rate consisting of rotten poles, crossarms, and braces along with cracked insulators, and worn hardware.
- Since 2016:
  - The Shinrock-Oberlin 69 kV Line had four (4) momentary and nine (9) sustained outages.
  - The Henrietta-Oberlin 69 kV Line had two (2) momentary and four (4) sustained outages.

## ATSI Transmission Zone M-3 Process Shinrock-Oberlin-Henrietta 69 kV Line Solution

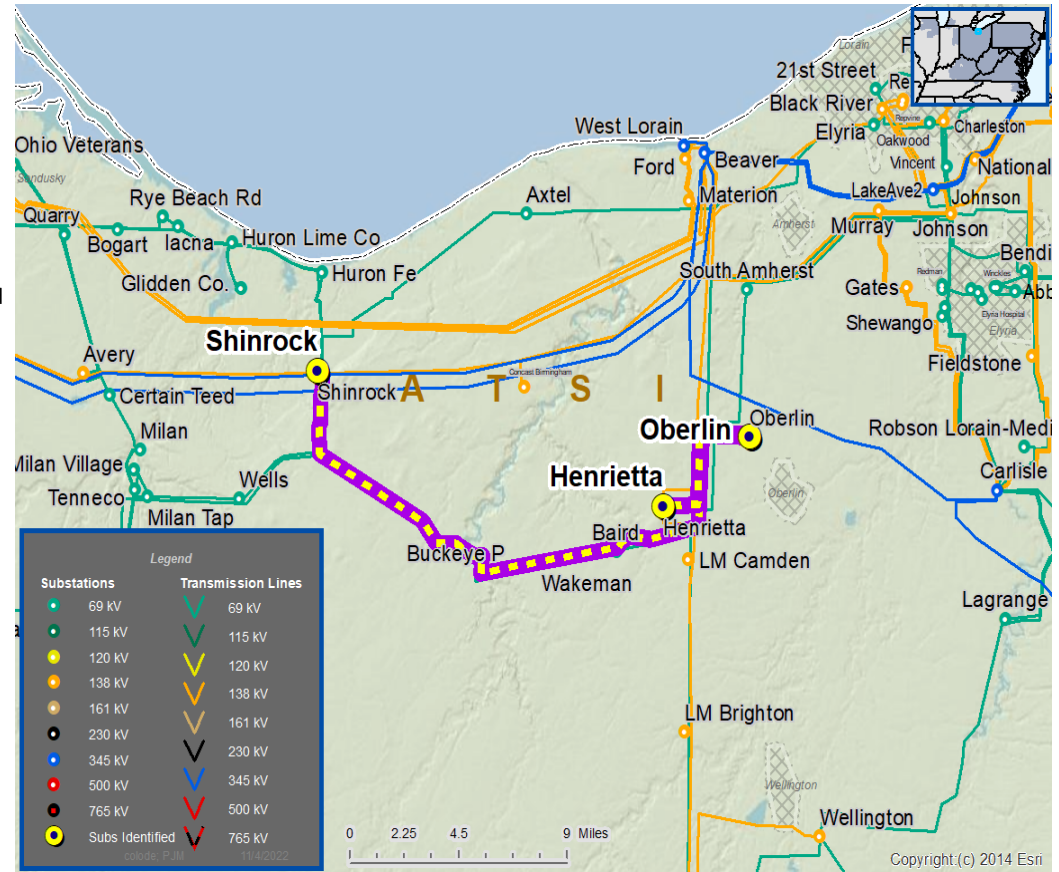



**Need Number:** ATSI-2022-014  
**Process Stage:** Submission of Supplemental Project for Inclusion in the Local Plan - 4/25/2023  
**Previously Presented:** Need Meeting – 06/15/2022  
 Solution Meeting – 11/18/2022

- Selected Solution:**
- Reroute and relocate the Shinrock-Oberlin Muni 69 kV line near structure 242 to the Oberlin Muni substation by building approximately 2.0 miles of new 69 kV line with 556 kcmil ACSR conductor in new ROW and on separate structures.
  - Terminate new line and coordinate relay settings changes at Oberlin Muni substation.
  - Revise relay settings at Shinrock substation.

**Transmission Line Ratings:**

- No change in rating

**Estimated Project Cost:** \$7.3 M  
**Projected IS Date:** 06/01/2024  
**Supplemental Project ID:** s2860.1

*Continued on next slide...*

SRRTEP Committee: Western – FirstEnergy Supplemental

## ATSI Transmission Zone M-3 Process Shinrock-Oberlin 69 kV Line Solution-Phase 1

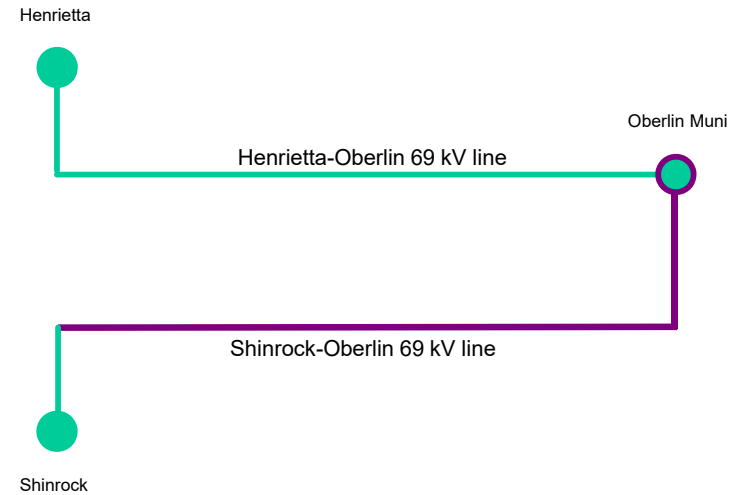

Legend	
500 kV	
345 kV	
138 kV	
69 kV	
34.5 kV	
23 kV	
New	



**Need Number:** ATSI-2022-014  
**Process Stage:** Submission of Supplemental Project for Inclusion in the Local Plan - 4/25/2023  
**Previously Presented:** Need Meeting – 06/15/2022  
 Solution Meeting – 11/18/2022

**Selected Solution:**

- Rebuild the double circuit portion of Shinrock-Oberlin and Henrietta – Oberlin lines into a single circuit from Henrietta to Oberlin Muni using 556.6 kcmil ACSR conductor.
- Remove the Shinrock-Oberlin Muni portion of the double circuit.
- Coordinate relay setting changes at Oberlin Muni substation.
- Revise relay settings at Henrietta substation.

**Transmission Line Ratings:**

- Before Proposed Solution:
  - Henrietta-Oberlin: 76 MVA SN / 90 MVA SE, 87 MVA WN / 103 MVA WE
- After Proposed Solution:
  - Henrietta-Oberlin : 76 MVA SN / 90 MVA SE, 93 MVA WN / 103 MVA WE

**Estimated Project Cost:** \$3.8 M

**Projected IS Date:** 12/31/2024

**Supplemental Project ID:** s2860.2

*Continued on next slide...*

## ATSI Transmission Zone M-3 Process Henrietta-Oberlin 69 kV Line Solution-Phase 2

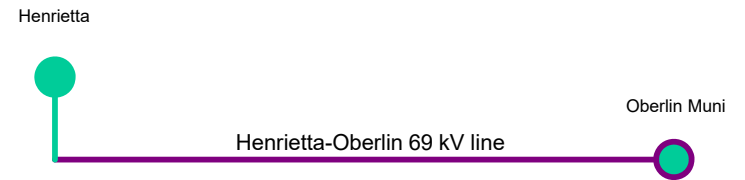

Legend	
500 kV	
345 kV	
138 kV	
69 kV	
34.5 kV	
23 kV	
New	



**Need Number:** ATSI-2022-014  
**Process Stage:** Submission of Supplemental Project for Inclusion in the Local Plan - 4/25/2023  
**Previously Presented:** Need Meeting – 06/15/2022  
 Solution Meeting – 11/18/2022

**Selected Solution:**

- Rebuild/rehab wood structures on Shinrock-Oberlin Muni 69 kV Line from Shinrock to structure 201 including taps to Baird and Buckeye Pipeline and reconductor line with 556 kcmil ACSR conductor. Wood structures heading north at structure 201 were installed in 2019 and are not in need of replacement.
- Upgrade substation conductor at Wakeman to make TL the most limiting element.
- Upgrade switches A-74, A-73, A-14, A-16, A-65, and A-45.
- Revise relay settings at Shinrock and Oberlin Muni substations.

**Transmission Line Ratings:**

- Shinrock-Oberlin 69 kV Line
  - Before Proposed Solution:
    - Shinrock – Buckeye Tap: 76 MVA SN / 92 MVA SE, 87 MVA WN / 111 MVA WE
    - Buckeye Tap - Wakeman: 60 MVA SN / 62 MVA SE, 69 MVA WN / 69 MVA WE
    - Wakeman – LMREC Baird : 52 MVA SN / 53 MVA SE, 60 MVA WN / 60 MVA WE
    - LMREC Baird – Oberlin : 76 MVA SN / 90 MVA SE, 87 MVA WN / 103 MVA WE
  - After Proposed Solution:
    - Shinrock – Buckeye Tap: 111 MVA SN / 134 MVA SE, 125 MVA WN / 159 MVA WE
    - Buckeye T - Wakeman: 111 MVA SN / 134 MVA SE, 125 MVA WN / 159 MVA WE
    - Wakeman – LMREC Baird : 111 MVA SN / 134 MVA SE, 125 MVA WN / 159 MVA WE
    - LMREC Baird – Oberlin : 76 MVA SN / 90 MVA SE, 93 MVA WN / 103 MVA WE

**Estimated Project Cost:** \$35.8 M

**Projected IS Date:** 12/31/2027

**Supplemental Project ID:** s2860.3

SRRTEP Committee: Western – FirstEnergy Supplemental

## ATSI Transmission Zone M-3 Process Shinrock-Oberlin 69 kV Line Solution-Phase 3

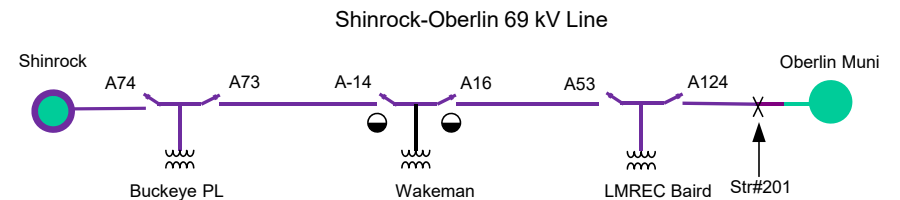

Legend	
500 kV	
345 kV	
138 kV	
69 kV	
34.5 kV	
23 kV	
New	



## ATSI Transmission Zone M-3 Process Relay Misoperation Projects

**Need Number:** ATSI-2022-Mutiple (See next slide)  
**Process Stage:** Submission of Supplemental Project for Inclusion in the Local Plan - 4/25/2023  
**Previously Presented:** Need Meeting - 07/22/2022  
 Solution Meeting – 11/18/2022

**Project Driver:**  
*Equipment Material Condition, Performance and Risk*

### Specific Assumption References:

#### Global Factors

- System reliability and performance
- Substation / line equipment limits

#### Upgrade Relay Schemes

- Relay schemes that have a history of misoperation
- Obsolete and difficult to repair communication equipment (DTT, Blocking, etc.)
- Communication technology upgrades

### Problem Statement:

- Since 2018 there have been seven (7) reportable misoperations in ATSI as a result of a power line carrier communication (PLC) issues and several other PLC systems have concerning health issues based on alarm and maintenance records.
- Per NATF reporting, DCB schemes are by far the most common protection scheme to misoperate accounting for over 31% of all reported misoperations.
- During the period of 2014-Q1 2018, 2.4% of misoperations in ATSI were due to the DCB protection scheme. Another 12% of misoperations were due to communication failures, relay failures and unknowns in a DCB-PLC configuration.
- Transmission line ratings are limited by terminal equipment.

Continued on next page...

SRRETP Committee: Western – FirstEnergy Supplemental

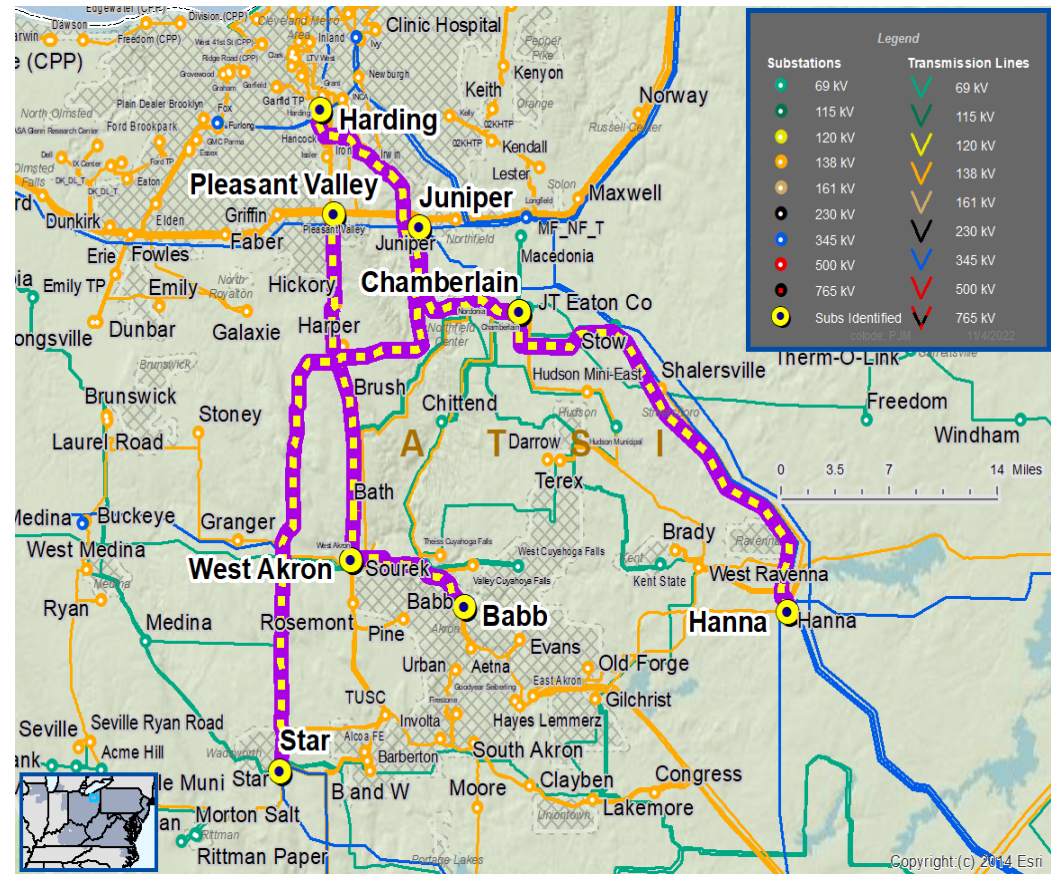



## ATSI Transmission Zone M-3 Process Relay Misoperation Projects

...Continued from previous page

ATSI-2022	Transmission Line / Substation Locations	Existing Line/Terminal Equipment MVA Rating (SN / SE)	Existing Conductor/Transformer MVA Rating (SN / SE)	Limiting Terminal Equipment
-016	Pleasant Valley-West Akron 138 kV Line (Pleasant Valley-Hickory section)	153 / 199 217 (WN) / 229 (WE)	237 / 287 267 (WN) / 339 (WE)	Wave trap, substation conductor at Pleasant Valley
-017	Chamberlin-Harding 345 kV Line	1555 / 1892 1766 (WN) / 2143 (WE)	1560/1900 1766 (WN) / 2251 (WE)	Substation conductor, Wave trap
-018	Chamberlin-Hanna 345 kV Line	1534 / 1878 1746 (WN) / 2143 (WE)	1542 / 1878 1746 (WN) / 2225 (WE)	Line Drop, substation conductor, Wave trap
-019	Juniper -Star 345 kV Line	1518 / 1849 1719 (WN) / 2143 (WE)	1518 / 1849 1719 (WN) / 2192 (WE)	Substation conductor, Wave trap
-021	Babb-West Akron 138 kV Line	190 / 209 217 (WN) / 223 (WE)	200 / 242 226 (WN) / 286 (WE)	Relay, substation conductor, wave trap



## ATSI Transmission Zone M-3 Process Relay Misoperation Projects

### Selected Solutions:

ATSI-2022	Transmission Line / Substation Locations	Supplemental Project ID	New MVA Line Rating (SN / SE)	Scope of Work	Estimated Cost (\$)	Target ISD
-016	Pleasant Valley-West Akron 138 kV Line (Pleasant Valley-Hickory section)	s2861	153 (SN) / 199 (SE) 219 (WN)/ 247(WE)	Migrate line relay communication to the SONET network, remove existing carrier schemes, install associated relay and communication equipment and remove the line wavetrapp (limiting element for winter ratings) at Pleasant Valley.	\$95k	12/11/2023
-017	Chamberlin-Harding 345 kV Line	s2862	1555 / 1892 1766 (WN) / 2160 (WE)	Migrate line relay communication to the SONET network, remove existing carrier schemes, install associated relay and communication equipment and remove the line wavetrapp (limiting element for winter emergency rating)	\$150k	9/26/2023
-018	Chamberlin-Hanna 345 kV Line	s2863	1534 / 1878 1746 (WN) / 2160 (WE)	Migrate line relay communication to the SONET network, remove existing carrier schemes, install associated relay and communication equipment and remove the line wavetrapp (limiting element for winter emergency rating)	\$315k	9/13/2023
-019	Juniper -Star 345 kV Line	s2864	1518 / 1849 1719 (WN) / 2160 (WE)	Migrate line relay communication to the SONET network, remove existing carrier schemes, install associated relay and communication equipment and remove the line wavetrapp (limiting element for winter emergency rating)	\$365k	10/31/2023
-021	Babb-West Akron 138 kV Line	s2865	190 / 225 226 (WN) / 258 (WE)	Migrate line relay communication to the SONET network, remove existing carrier schemes, install associated relay and communication equipment and remove the line wavetrapp (limiting element for summer emergency & winter ratings)	\$135k	12/30/2023





## ATSI Transmission Zone M-3 Process Fowles 138 kV Substation

**Need Number:** ATSI-2022-025  
**Process Stage:** Submission of Supplemental Project for Inclusion in the Local Plan - 4/25/2023  
**Previously Presented:** Need Meeting – 09/16/2022  
 Solution Meeting – 11/18/2022

**Supplemental Project Driver(s):**  
*Operational Flexibility and Efficiency*  
*Equipment Material Condition, Performance, and Risk*  
*Infrastructure Resilience*

**Specific Assumption Reference(s)**

**Global Factors**

- System Reliability and Performance
- Load at risk in planning and operational scenarios
- Upgrade Relay Schemes – Protection Systems with single points of failure
- Substation/line Equipment Limits

**Problem Statement**

The existing Fowles Substation’s 138 kV No. 1 and No. 3 bus protection is a single scheme with no redundancy.

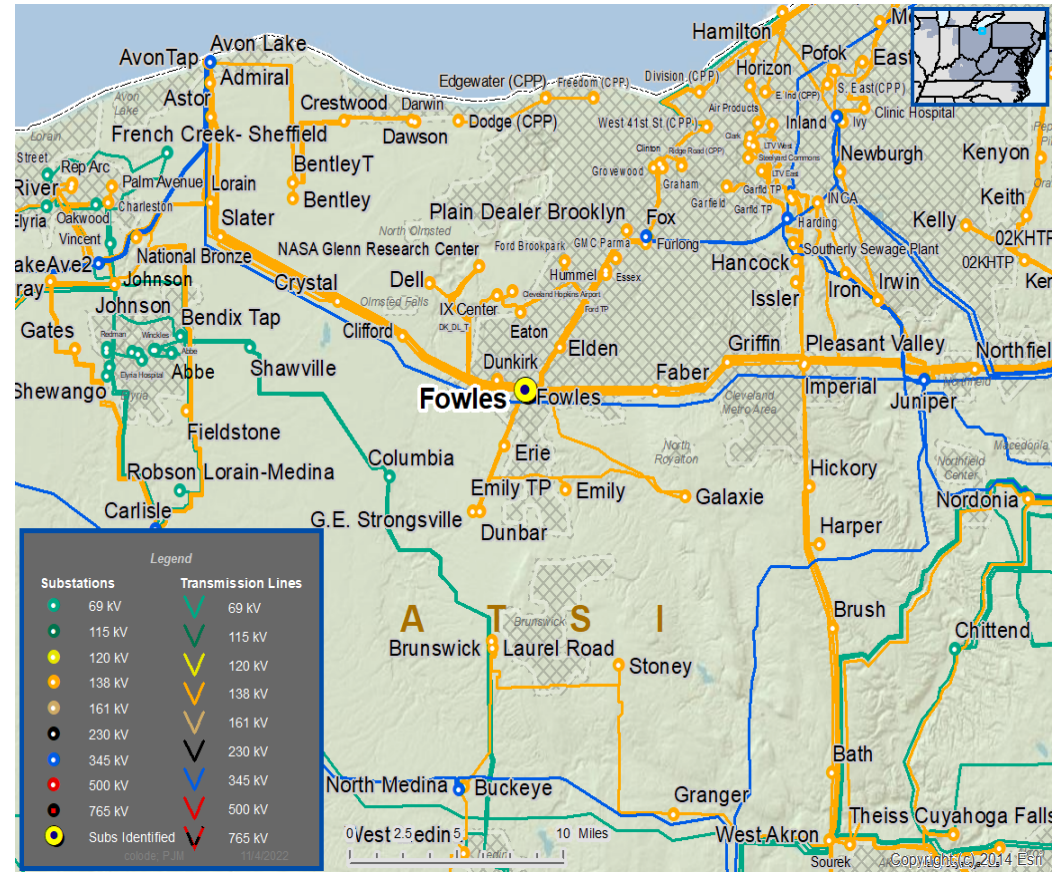





## ATSI Transmission Zone M-3 Process Fowles 138 kV Substation Solution

**Need Number:** ATSI-2022-025  
**Process Stage:** Submission of Supplemental Project for Inclusion in the Local Plan - 4/25/2023  
**Previously Presented:** Need Meeting – 09/16/2022  
 Solution Meeting – 11/18/2022

**Selected Solution:**

**Fowles 138 kV Substation**

- Upgrade Fowles Substation’s 138kV No. 1 and No. 3 bus relaying with primary and backup protection scheme
- Replace (1) six-pole 138 kV switch (D304 & D305) with (2) 1200 A manually operated GOAB switches.
- Remove linear couplers for several 138 kV breakers and install slip-over CTs.
- Replace and install new relaying equipment for Bus No.1 and Bus No.2 with a dual 487B relay panel.
- Replace limiting substation conductors.

**Transmission Line Ratings:**

- Fowles – Pleasant Valley Q3 138 kV Line
  - Before project: 267 MVA SN / 332 MVA SE
  - After project: 273 MVA SN / 332 MVA SE
- Fowles – Fox Q13 138 kV Line
  - Before project: 265 MVA SN / 332 MVA SE
  - After project: 273 MVA SN / 332 MVA SE
- Avon – Fowles Q1 138 kV Line
  - Before project: 265 MVA SN / 332 MVA SE
  - After project: 273 MVA SN / 332 MVA SE
- Fox – Fowles Q12 138 kV Line
  - Before project: 265 MVA SN / 332 MVA SE
  - After project : 273 MVA SN / 332 MVA SE

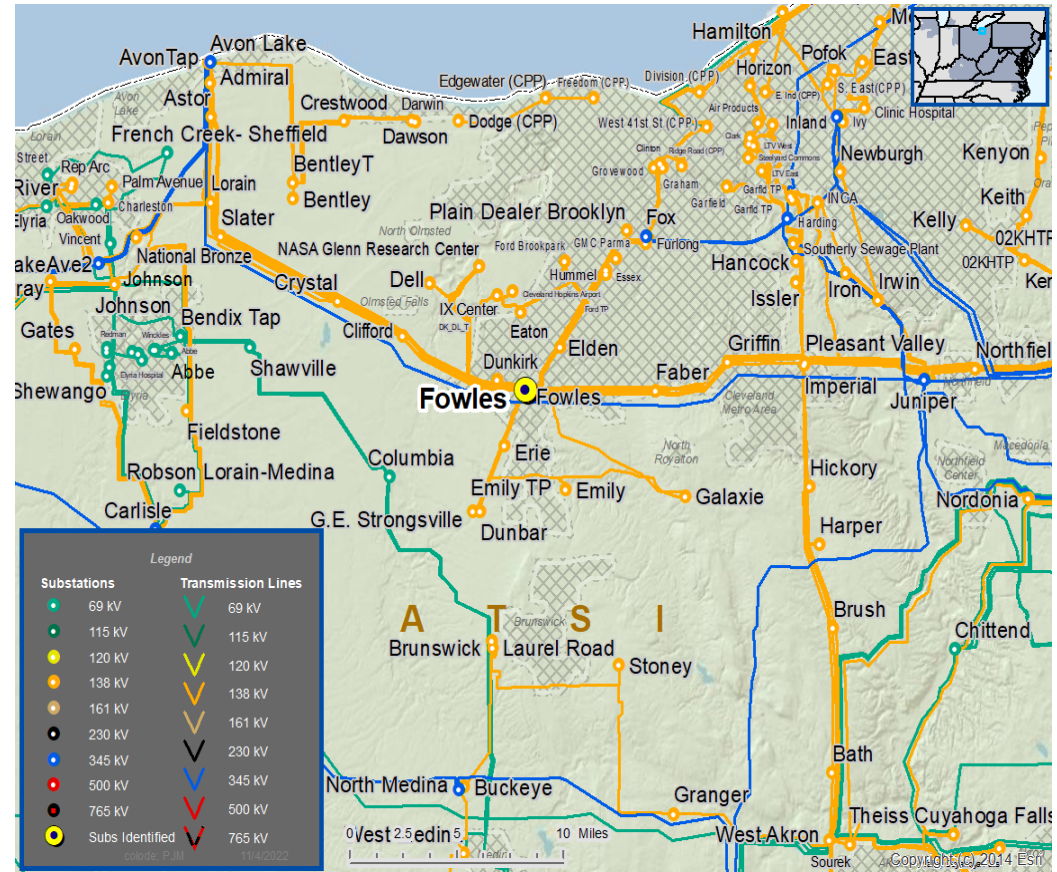

Continued on next slide...



## ATSI Transmission Zone M-3 Process Fowles 138 kV Substation Solution

**Need Number:** ATSI-2022-025  
**Process Stage:** Submission of Supplemental Project for Inclusion in the Local Plan - 4/25/2023  
**Previously Presented:** Need Meeting – 09/16/2022  
 Solution Meeting – 11/18/2022  
**Estimated Project Cost:** \$0.62M  
**Projected In-Service:** 12/31/2023  
**Supplemental Project ID:** s2866

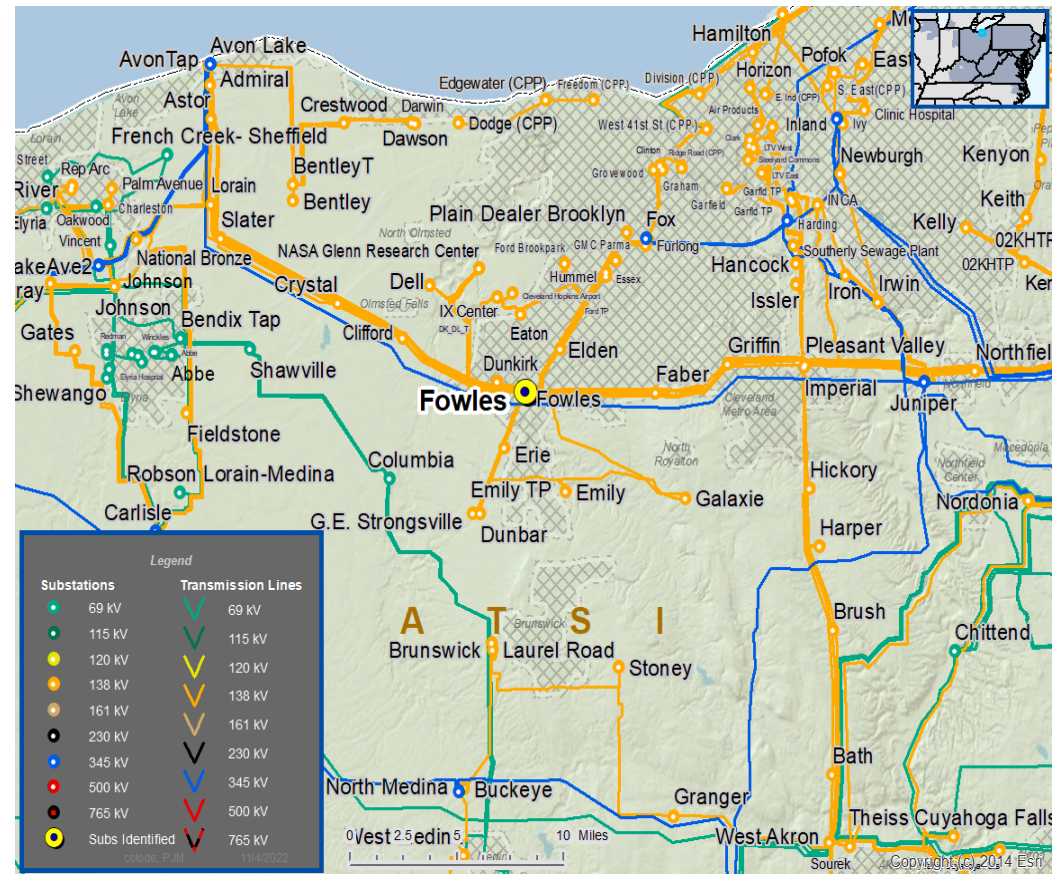



## ATSI Transmission Zone M-3 Process Midway 138 kV Substation

**Need Number:** ATSI-2022-024  
**Process Stage:** Submission of Supplemental Project for Inclusion in the Local Plan - 4/25/2023  
**Previously Presented:** Need Meeting – 09/16/2022  
 Solution Meeting – 11/18/2022

**Supplemental Project Driver(s):**  
*Operational Flexibility and Efficiency*  
*Equipment Material Condition, Performance, and Risk*  
*Infrastructure Resilience*

- Specific Assumption Reference(s)**
- System Reliability and Performance
  - Load at risk in planning and operational scenarios
  - Upgrade Relay Schemes – Protection Systems with single points of failure
  - Expected service life (at or beyond) or obsolescence

**Problem Statement**

- The existing Midway Substation’s 138 kV J and K bus protection is a single scheme with no redundancy.
- Oil Circuit Breakers ages and concerns:
  - B13301 is 40 years old.
  - B13303 is 54 years old with high dwell time.
  - B13305 is 50 years old with high dwell time.
  - B13308 is 47 years old.

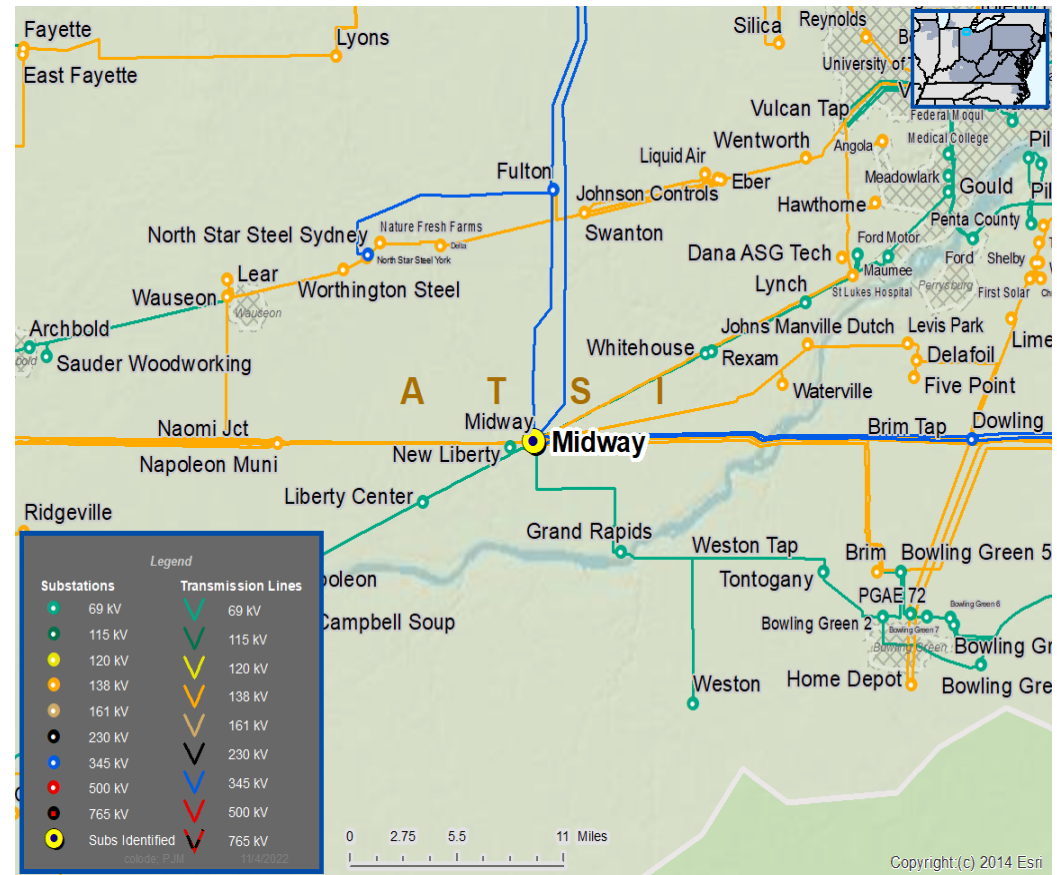





## ATSI Transmission Zone M-3 Process Midway 138 kV Substation

**Need Number:** ATSI-2022-024  
**Process Stage:** Submission of Supplemental Project for Inclusion in the Local Plan - 4/25/2023  
**Previously Presented:** Need Meeting – 09/16/2022  
 Solution Meeting – 11/18/2022

**Selected Solution:**

**Midway 138 kV Substation**

- Replace breakers 13301, 13303 and 13308. Breaker 13305 is to be replaced under supplemental project s1698.
- Replace line and bus disconnect switches.
- For the Angola terminal line: replace wave trap and tuner, replace limiting terminal conductor, CVT, and revise relay settings on the Angola PR relay.
- Replace 138 kV VTs with CVTs for both J & K Bus.
- Replace J & K Bus relays with a dual 487B relay panels.

**Transmission Line Ratings:**

- Angola-Midway 138 kV Line
  - Before project: 288 MVA SN/346 MVA SE
  - After project: 288 MVA SN/353 MVA SE

**Estimated Project Cost:** \$1.8 M  
**Projected In-Service:** 12/31/2023  
**Supplemental Project ID:** s2867

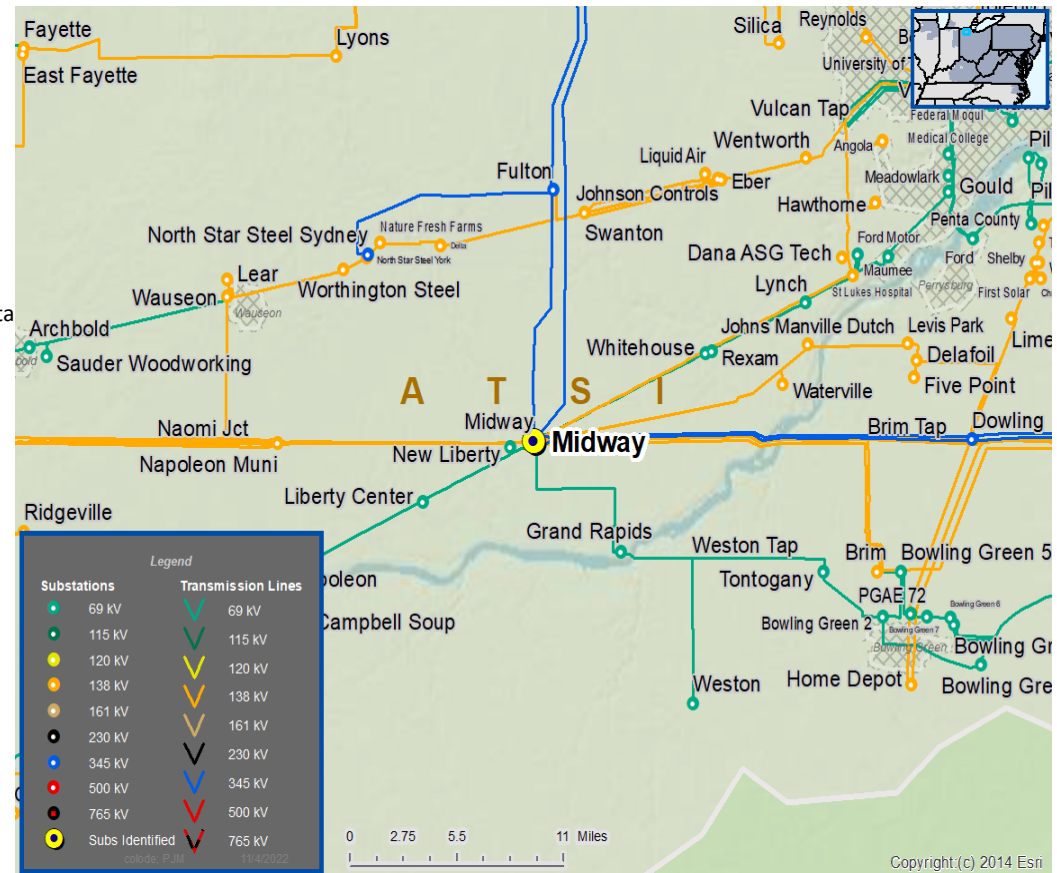



## ATSI Transmission Zone M-3 Process McDowell Breakers B-16 and B-30

**Need Number:** ATSI-2022-010  
**Process Stage:** Submission of Supplemental Project for Inclusion in the Local Plan - 4/25/2023  
**Previously Presented:** Need Meeting – 05/19/2022  
 Solution Meeting – 11/18/2022

**Supplemental Project Driver(s):**  
*Equipment Material Condition, Performance and Risk Infrastructure Resilience*

**Specific Assumption Reference(s):**

**Global Factors**

- System Reliability and Performance
- Increasing negative trend in maintenance findings and/or costs
- Expected service life (beyond) or obsolescence
- Costs for repair approach cost for replacement
- Substation/line Equipment Limits

**Substation Condition Rebuild/Replacement**

- Circuit breakers and other fault interrupting devices
- Switches and relays

**Problem Statement**

- Oil Circuit Breakers B-16 and B-30 and associated disconnect switches at McDowell are showing increasing maintenance concerns; compressor issues, valve issues, trip coil failure pilot valve failure deteriorated operating mechanisms, timing issues, and increasing maintenance trends.
- Breaker B-16 is 44 years old; Breaker B-30 is 72 years old
- Similar breaker B-26 recently failed

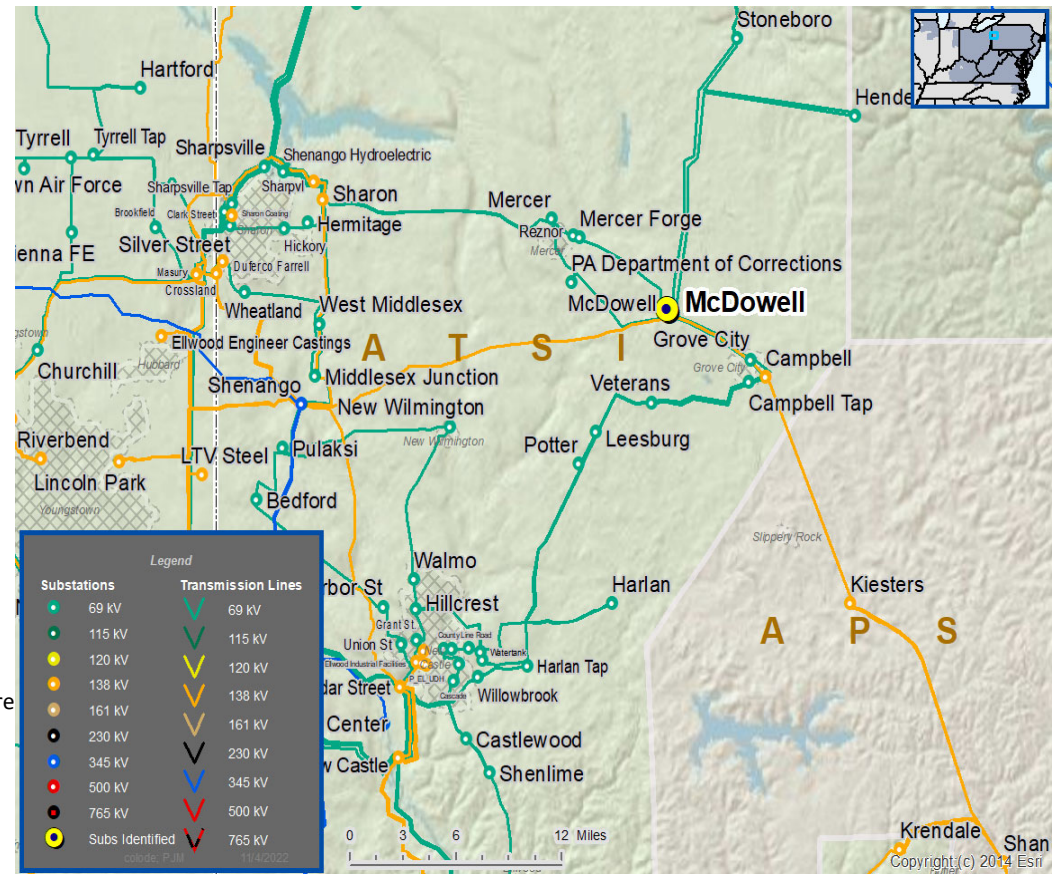



## ATSI Transmission Zone M-3 Process McDowell Breakers B-16 and B-30

**Need Number:** ATSI-2022-010  
**Process Stage:** Submission of Supplemental Project for Inclusion in the Local Plan - 4/25/2023  
**Previously Presented:** Need Meeting – 05/19/2022  
 Solution Meeting – 11/18/2022

**Selected Solution:**

**McDowell Breakers Replacements**

- Replace 69 kV breakers B-16 and B-30, and associated line and bus disconnect switches.
- Replace the Campbell and Campbell Tap relays with line relay panels and install SEL-421 primary/backup relays and SEL501 with LOR BF relays.
- Replace limiting substation conductors.

**Transmission Line Ratings:**

- Campbell T-McDowell Y-10 69 kV line section:
  - Before Proposed Solution: 48 MVA SN / 48 MVA SE / 48 MVA WN / 48 MVA WE
  - After Proposed Solution: 80 MVA SN / 96 MVA SE / 90 MVA WN / 114 MVA WE
- McDowell- G.E. TSD Grove City T 69 kV line section:
  - Before Proposed Solution: 72 MVA SN / 72 MVA SE / 72 MVA WN / 72 MVA WE
  - After Proposed Solution: 80 MVA SN / 96 MVA SE / 90 MVA WN / 114 MVA WE

**Estimated Project Cost:** \$1.5 M  
**Projected In-Service:** 12/30/2023  
**Supplemental Project ID:** s2868

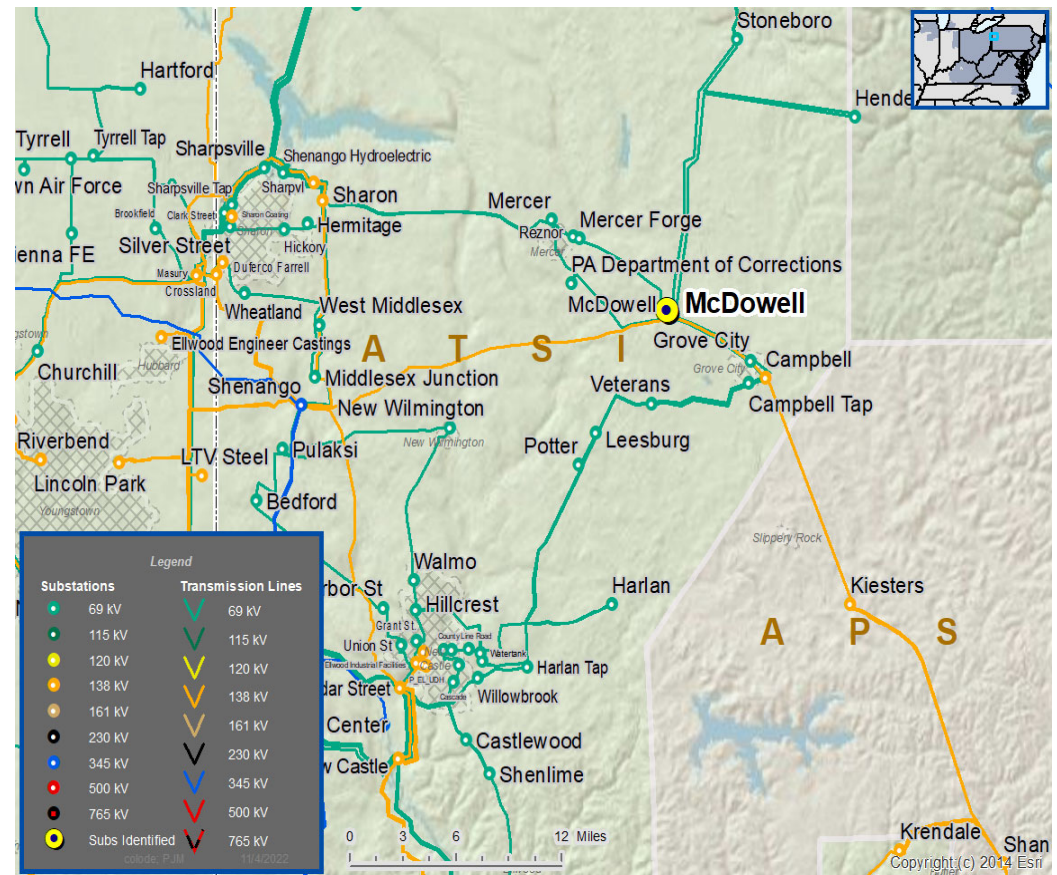





## ATSI Transmission Zone M-3 Process Sharon 69 kV Substation

**Need Number:** ATSI-2020-045  
**Process Stage:** Submission of Supplemental Project for Inclusion in the Local Plan - 4/25/2023  
**Previously Presented:** Need Meeting – 11/20/2020  
 Solution Meeting – 11/18/2022

**Supplemental Project Driver(s):**  
*Equipment Material Condition, Performance, and Risk Infrastructure Resilience*

**Specific Assumption Reference(s):**

**Global Factors**

- Level of criticality to system performance and operations
- Customer outage frequency and/or durations
- Increasing negative trend in maintenance findings and/or costs
- Failure risk, to the extent caused by asset design characteristics, or historical industry/company performance data, or application design error

**Problem Statement**

- The 69 kV lines at the Sharon 69 kV substation have a single set of relays providing protection.
- The Sharon 69 kV bus has a single bus protection scheme.
- There is no breaker failure presently installed on the Sharon 69 kV exposing this sub and its lines to risk of a larger outage if one of these schemes were to fail to operate.
- In June 2018, an uncleared fault on Y-300 line to McDowell led to a widespread outage of all the 69 kV lines from Sharon.

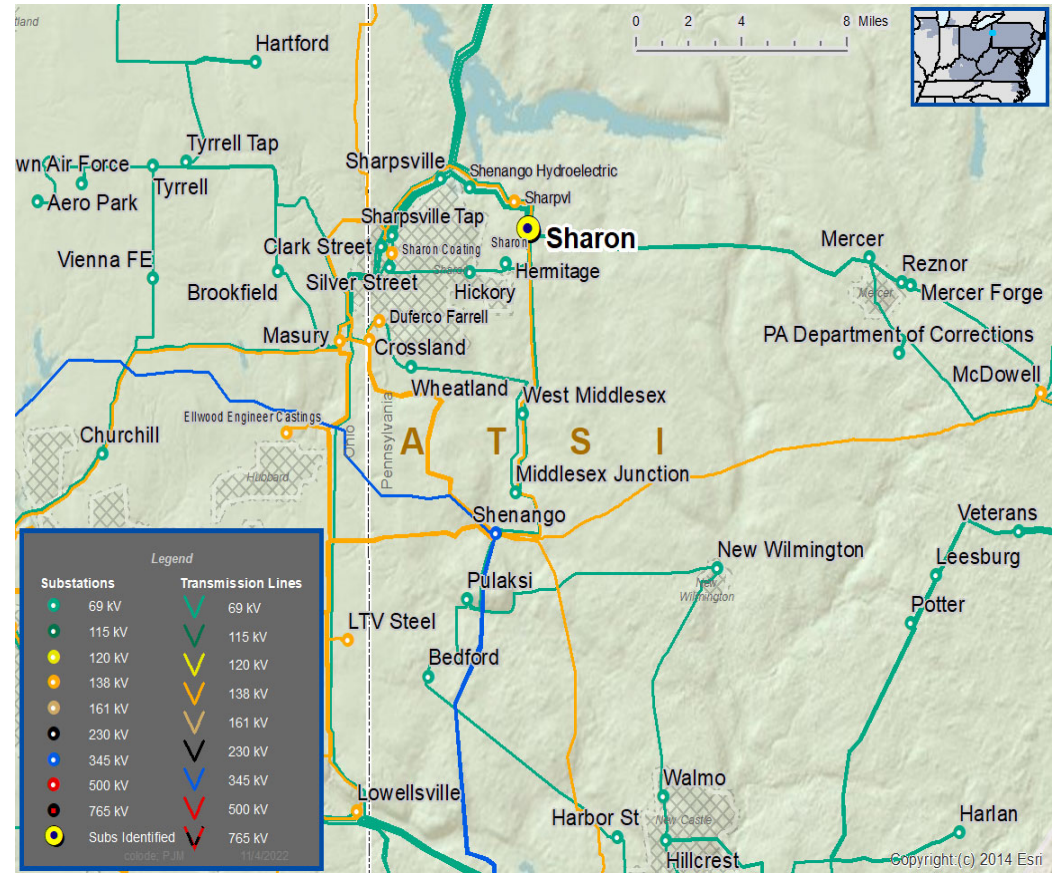



## ATSI Transmission Zone M-3 Process Sharon 69 kV Substation

**Need Number:** ATSI-2020-045  
**Process Stage:** Submission of Supplemental Project for Inclusion in the Local Plan - 4/25/2023  
**Previously Presented:** Need Meeting – 11/20/2020  
 Solution Meeting – 11/18/2022

### Selected Solution:

- Replace relaying & controls at Sharon substation for the following lines:
  - Sharon – Maysville Y-299/Y-81 69 kV Line
  - Sharon – McDowell Y-300 69 kV Line
  - Sharon – Maysville Y-301 69 kV Line
  - Sharon – Masury Y-188/Y-303 69 kV Line
- Install a new 69 kV control building at Sharon substation
- Adjust relay settings at Masury, Maysville, & McDowell substations
- Install a new standard large RTU panel and a new standard HMI Panel

### Transmission Line Ratings:

- Branch: Sharon T - Sharon Y81 69 kV
  - Before Proposed Solution: 72 MVA SN / 76 MVA SE / 76 MVA WN / 76 MVA WE
  - After Proposed Solution: 72 MVA SN / 91 MVA SE / 95 MVA WN / 123 MVA WE
- Branch: Mercer T – Sharon Y300 69 kV
  - Before Proposed Solution: 72 MVA SN / 72 MVA SE / 72 MVA WN / 72 MVA WE
  - After Proposed Solution: 80 MVA SN / 96 MVA SE / 90 MVA WN / 114 MVA WE
- Branch: McDowell – Dept of Corrections Y300 69 kV
  - Before Proposed Solution: 47 MVA SN / 48 MVA SE / 48 MVA WN / 48 MVA WE
  - After Proposed Solution: 47 MVA SN / 56 MVA SE / 53 MVA WN / 67 MVA WE

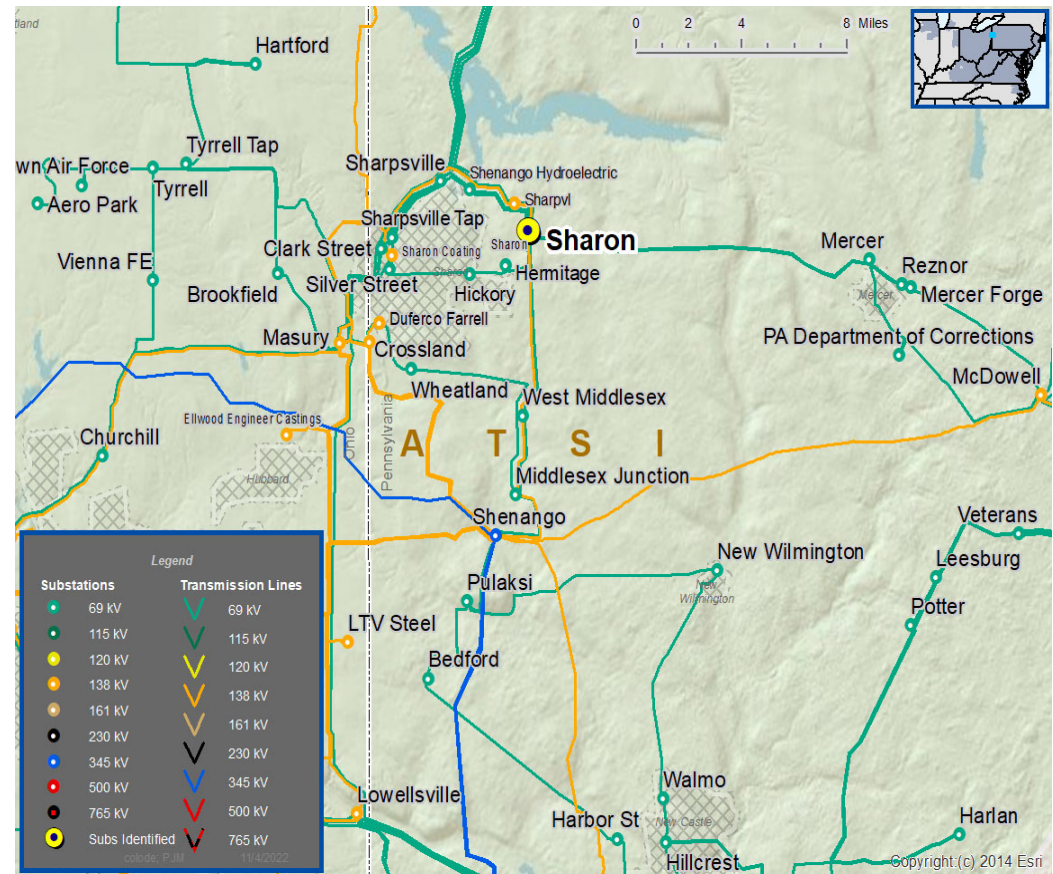





## ATSI Transmission Zone M-3 Process Sharon 69 kV Substation

**Need Number:** ATSI-2020-045  
**Process Stage:** Submission of Supplemental Project for Inclusion in the Local Plan - 4/25/2023  
**Previously Presented:** Need Meeting – 11/20/2020  
 Solution Meeting – 11/18/2022

**Transmission Line Ratings:**

- Branch: Camp Reynolds – Sharon Y301 69 kV
  - Before Proposed Solution: 69 MVA SN / 72 MVA SE / 72 MVA WN / 72 MVA WE
  - After Proposed Solution: 69 MVA SN / 83 MVA SE / 78 MVA WN / 98 MVA WE
- Branch: West Middlesex T – Sharon Y303 69 kV
  - Before Proposed Solution: 100 MVA SN / 121 MVA SE / 113 MVA WN / 121 MVA WE
  - After Proposed Solution: 100 MVA SN / 121 MVA SE / 113 MVA WN / 143 MVA WE

**Estimated Project Cost:** \$20.8 M  
**Projected In-Service:** 06/01/2025  
**Supplemental Project ID:** s2869

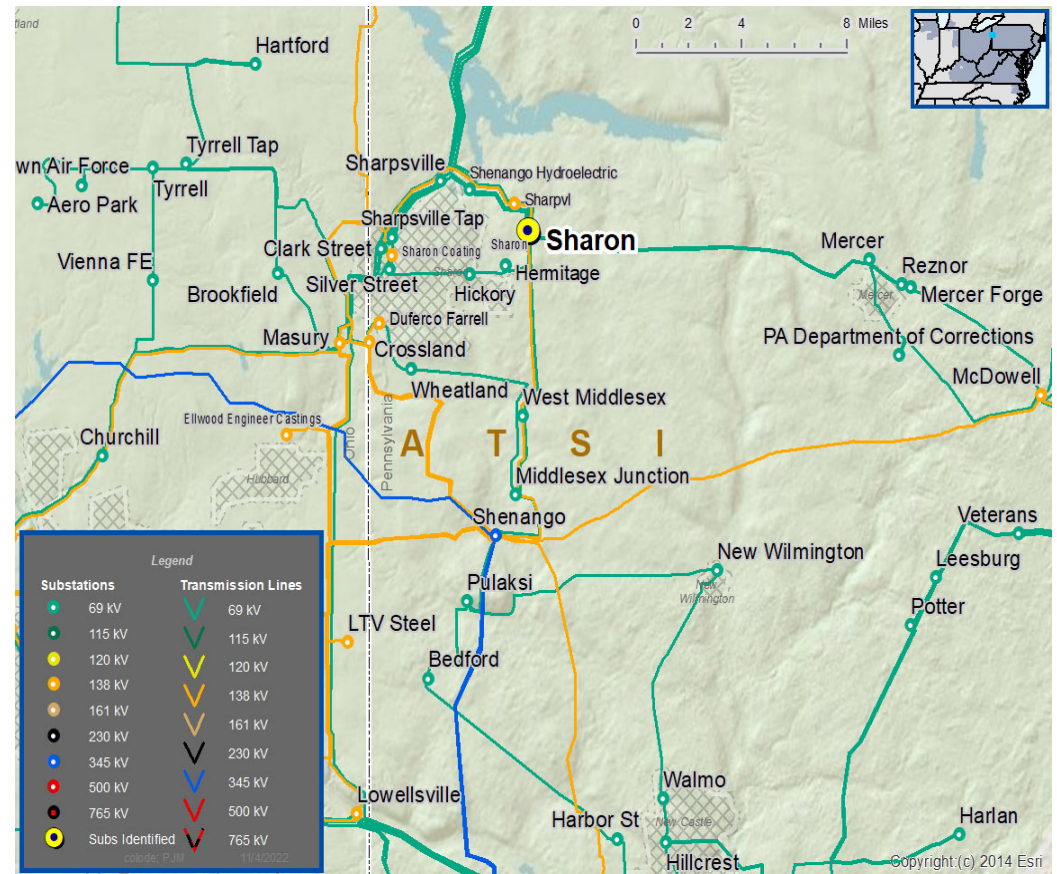

# AMPT Projects in AEP Transmission Zone M3 Process Deshler, OH

**Need Number:** AMPT-2021-004

**Process Stage:** Submission of Supplemental Project for Inclusion in the Local Plan - 4/25/2023

**Previously Presented:** Solution Meeting – 9/16/2022, Need Meeting – 11/19/2021

**Supplemental Project Driver(s):** Customer Service

**Specific Assumption Reference(s):** AMPT Transmission Facilities Interconnection Requirements Document

**Problem Statement:**

AMPT's Deshler Tap is an approximately 10.7 mile radial 69 kV tap supplied from AEP's East Leipsic-East Ottawa 69 kV line. Three stations are served off the Tap – Belmore Co-op, Deshler South, and Deshler North.

The village of Deshler has requested a 2<sup>nd</sup> supply to support the load (approximately 4.2 MVA). The radial supply presents a single point of failure that could jeopardize reliability for the village.

AMPT's Transmission Facilities Interconnection Requirements specify looped facilities for loads exceeding 5 MVA or 35 MW-mile thresholds.

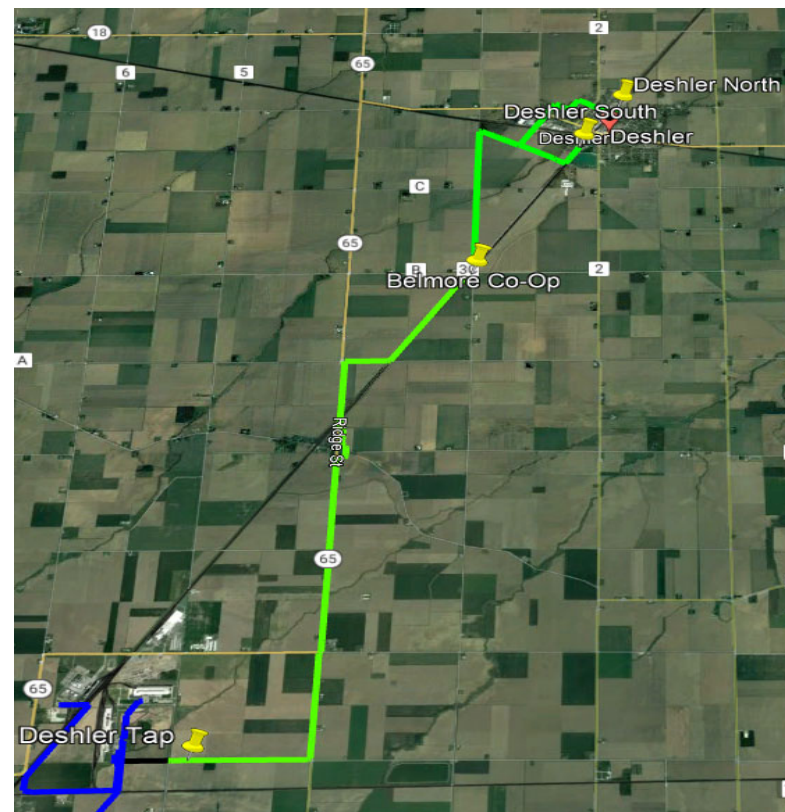

# AMPT Projects in AEP Transmission Zone M3 Process Deshler, OH

**Need Number:** AMPT-2021-004

**Process Stage:** Submission of Supplemental Project for Inclusion in the Local Plan - 4/25/2023

**Supplemental Project Driver(s):** Customer Service

**Selected Solution:**

*FE Identified Scope (Estimated Transmission Cost: \$1.9 M)*

- Install one 69 kV circuit breaker and associated equipment at FE's Weston 69 kV substation.
- Install one span of conductor to a structure outside the FE Weston 69 kV substation.
- Install tie line interchange revenue metering at FE's Weston 69 kV substation.

**Projected In-Service:** 8/1/2025

**Supplemental Project ID:** s2827.3

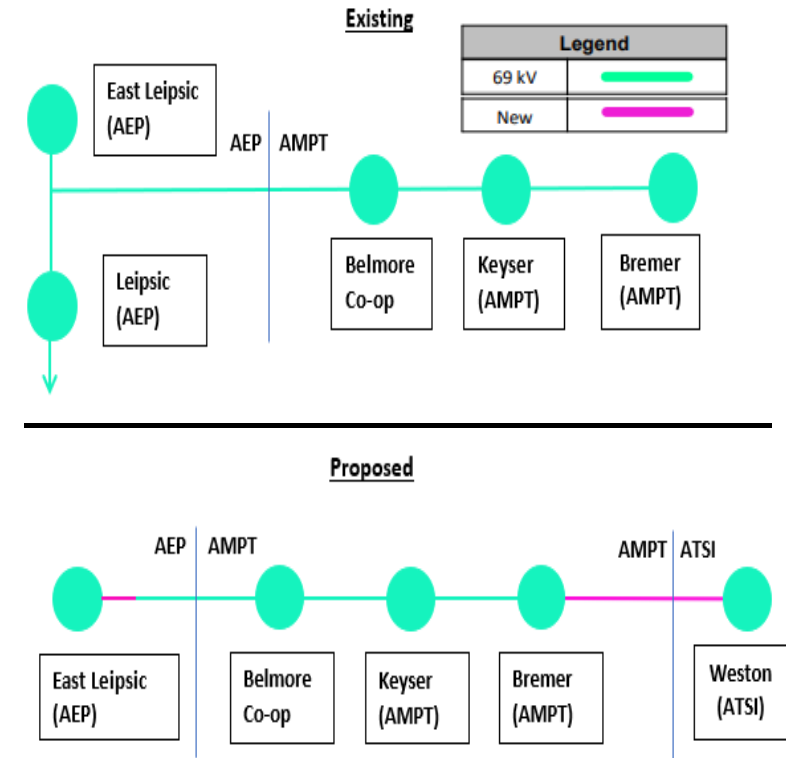



## ATSI Transmission Zone M3 Process Brewster, OH

**Need Number:** AMPT-2021-006

**Process Stage:** Submission of Supplemental Project for Inclusion in the Local Plan - 4/25/2023

**Previously Presented:** Need Meeting – 12/17/2021  
Solution Meeting – 8/19/2022

**Supplemental Project Driver(s):** Customer Service

**Specific Assumption Reference(s):** AMPT’s “Transmission Facilities Interconnection Requirements” document.

**Problem Statement:**  
The existing interconnection is an approximately 3.5 mile radial 69 kV line from ATSI’s Harmon substation. Current peak load at Brewster is 9 MW.

The village of Brewster has requested a 2<sup>nd</sup> supply to support the load. The radial supply presents a single point of failure that could jeopardize reliability for the village. AMPT Interconnection requirements specify a need for a second source for loads 5 MW and above.

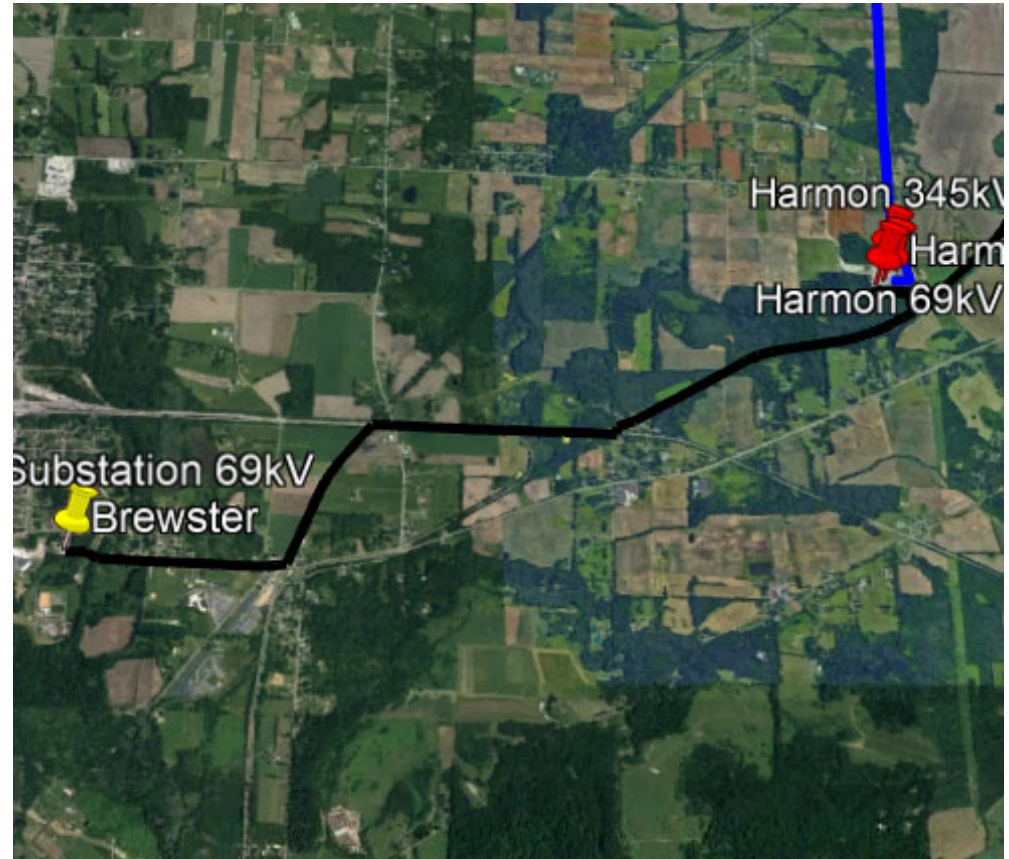





## ATSI Transmission Zone M3 Process Brewster, OH

**Need Number:** AMPT-2021-006  
**Process Stage:** Submission of Supplemental Project for  
 Inclusion in the Local Plan - 4/25/2023

**Supplemental Project Driver(s):** Customer Service

**Selected Solution:**

*FE Identified Scope*

- At FE's Harmon substation provide fiber termination. AMPT is responsible for the fiber path on the Brewster-Harmon 69 kV line.
- At FE's Harmon 69 kV substation replace two (2) SEL-421s primary and backup relay with two (2) SEL-4111s and connect to the fiber, retain existing SEL-501 breaker failure relay.
- Adjust relay settings at Cloverdale

**Estimated Transmission Cost:** \$0.63 M  
**Projected In-Service:** 6/1/2025  
**Supplemental Project ID:** s2807.3

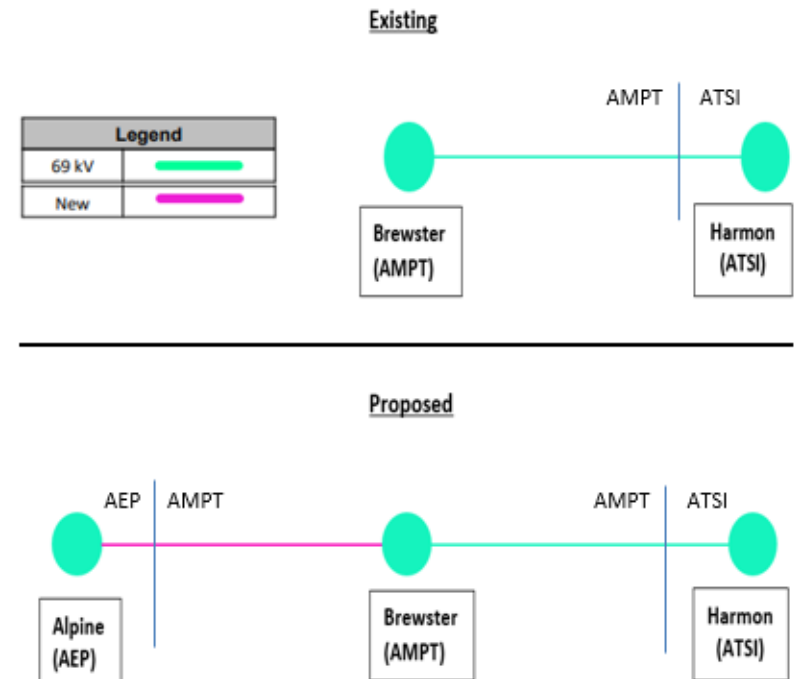



**Need Number:** ATSI-2021-016  
**Process Stage:** Submission of Supplemental Project for Inclusion in the Local Plan - 7/11/2023  
**Presently Presented:** Need Meeting – 08/16/2021  
 Solution Meeting – 03/17/2023

**Supplemental Project Driver(s):**  
*Equipment Material Condition, Performance, and Risk Infrastructure Resilience*

**Specific Assumption Reference(s):**

Global Factors

- System Reliability and Performance
- Load at risk in planning and operational scenarios
- Increase line loading limits
- Age/condition of transmission line conductors

Line Condition Rebuild/Replacement

- Transmission lines with loading at 80% or greater

**Problem Statement**

- The Leroy Center – Mayfield Q3 138 kV line loads to 89% under contingency conditions in the latest RTEP Case.
- The Leroy Center – Mayfield Q3 138 kV line feeds 4,938 customers and 21 MW at the Pinegrove Substation.
- The existing conductor is 4/0 CU and can cause protection issues due to not being able to handle the short circuit current for faults.
- Age/condition of transmission line conductors and hardware (mid 1940s).

## ATSI Transmission Zone M-3 Process Leroy Center - Mayfield Q3 138 kV

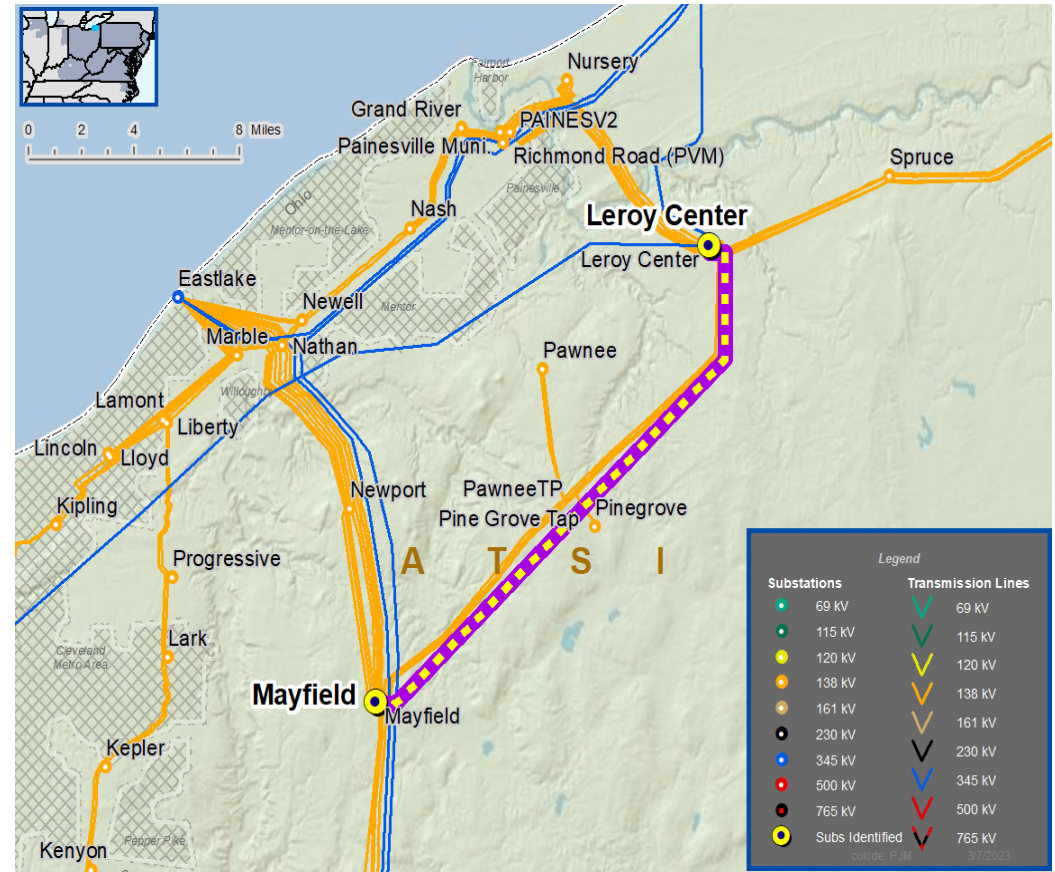



## ATSI Transmission Zone M-3 Process Leroy Center - Mayfield Q3 138 kV

**Need Number:** ATSI-2021-016  
**Process Stage:** Submission of Supplemental Project for Inclusion in the Local Plan - 7/11/2023

**Selected Solution:**  
 Reconductor approximately 7.7 miles 138 kV line section from Mayfield to Pinegrove with 336 ACSS, insulators and cold end attachments will be replaced, as needed.  
 Relay setting changes at Mayfield

**Estimated Cost:** \$16.0M  
**Supplemental Project ID:** s2923.1  
**Projected In-Service:** 06/01/2025

Reconductor approximately 8.1 miles 138 kV line section from Leroy Center to Pinegrove with 336 ACSS, insulators and cold end attachments will be replaced, as needed.  
 Relay setting changes at Leroy Center  
**Estimated Cost:** \$15.7M  
**Supplemental Project ID:** s2923.2  
**Projected In-Service:** 06/01/2024

**Transmission Line Ratings:**  
 Leroy Center – Mayfield 138 kV Line  
 Before Proposed Solution: 148 MVA SN/ 151 MVA SE  
 After Proposed Solution: 252 MVA SN / 291 MVA SE

**Total Estimated Project Cost:** \$31.7M  
**Model:** 2020 Series 2025 Summer RTEP 50/50

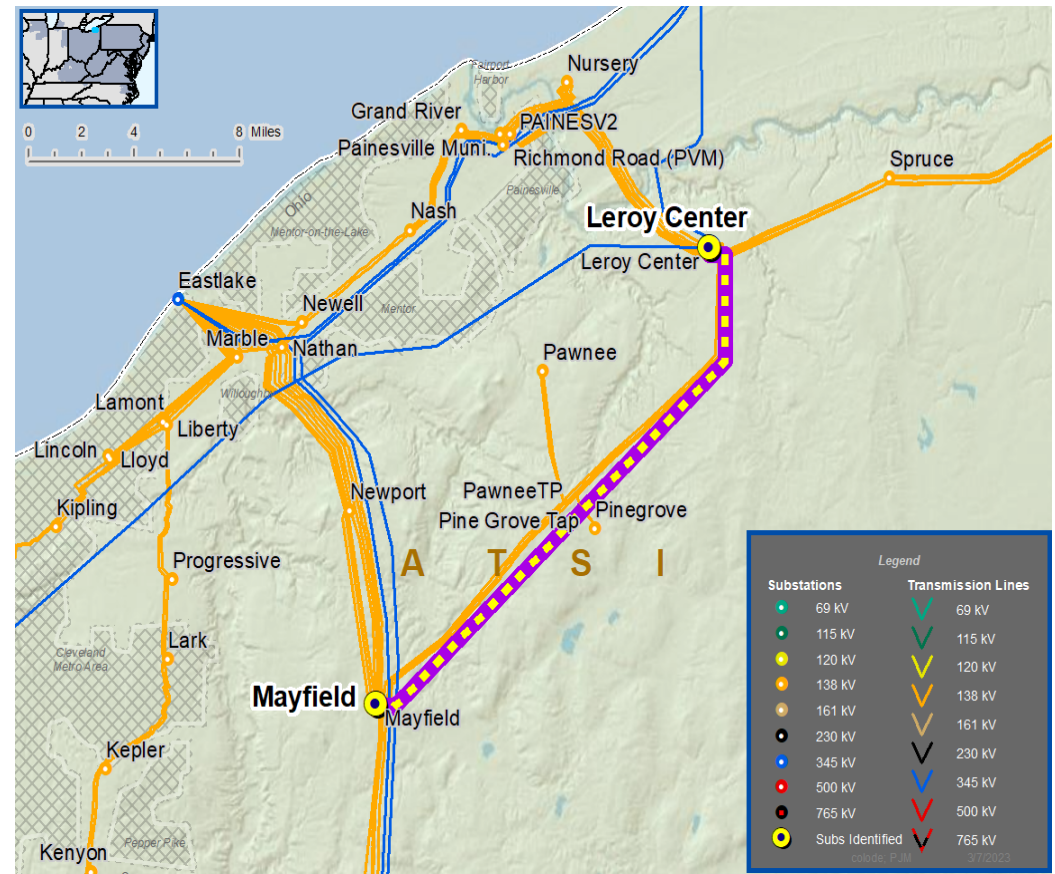



## ATSI Transmission Zone M-3 Process Leroy Center - Mayfield Q1 138 kV

**Need Number:** ATSI-2022-007  
**Process Stage:** Submission of Supplemental Project for Inclusion in the Local Plan -7/11/2023  
**Presently Presented:** Need Meeting – 03/18/2022  
 Solution Meeting – 03/17/2023

**Supplemental Project Driver(s):**  
*Equipment Material Condition, Performance, and Risk  
 Infrastructure Resilience*

**Specific Assumption Reference(s):**

**Global Factors**

- System Reliability and Performance
- Increasing negative trend in maintenance findings
- Age/condition of transmission line conductors and hardware

**Line Condition Rebuild/Replacement**

- End of Life Methodology

**Problem Statement**

- The Leroy Center – Mayfield Q1 138 kV Line (~16.1 miles) originally constructed mid-1940's, and all structures are similar vintage.
- Leroy Center – Pawnee Tap Q1 138 kV line section (~8.4 miles) is being reconducted and addressed under RTEP# b3152
- Pawnee Tap – Mayfield Q1 138 kV line (~7.7 miles) section:
  - 71 of 119 structures inspected had measurable cold end attachment plate wear with instances of mounting holes being 75% worn.
  - Age/condition of transmission line conductors and hardware (mid 1940s).

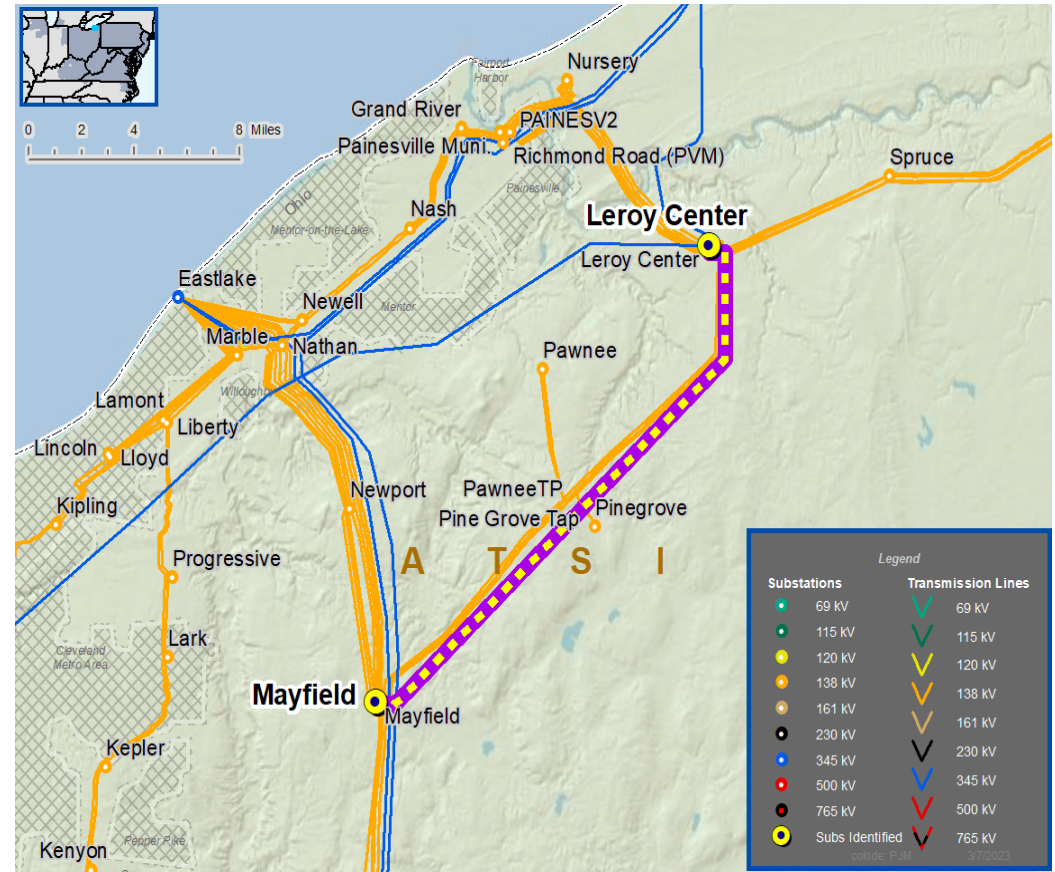





## ATSI Transmission Zone M-3 Process Leroy Center - Mayfield Q1 138 kV

**Need Number:** ATSI-2022-007  
**Process Stage:** Submission of Supplemental Project for Inclusion in the Local Plan - 7/11/2023

### Selected Solution:

- Reconductor approximately 7.7-mile 138 kV line section from Pawnee tap to Mayfield (Q1) with 336 ACSS. Replace tower structures, insulators and hardware as needed to address condition items and support new conductor.
- Revise relay settings at Mayfield, Leroy Center, and Pawnee
- Leroy Center – Pawnee Q1 138 kV line section is being reconducted under baseline project RTEP b3152

### Transmission Line Ratings:

- Pawnee Tap - Mayfield Q1
  - Before Proposed Solution: 115 MVA SN/ 115 MVA SE
  - After Proposed Solution: 252 MVA SN / 291 MVA SE

**Estimated Project Cost:** \$15.2M

**Projected In-Service:** 06/01/2026

**Supplemental Project ID:** s2924

**Model:** 2020 Series 2025 Summer RTEP 50/50

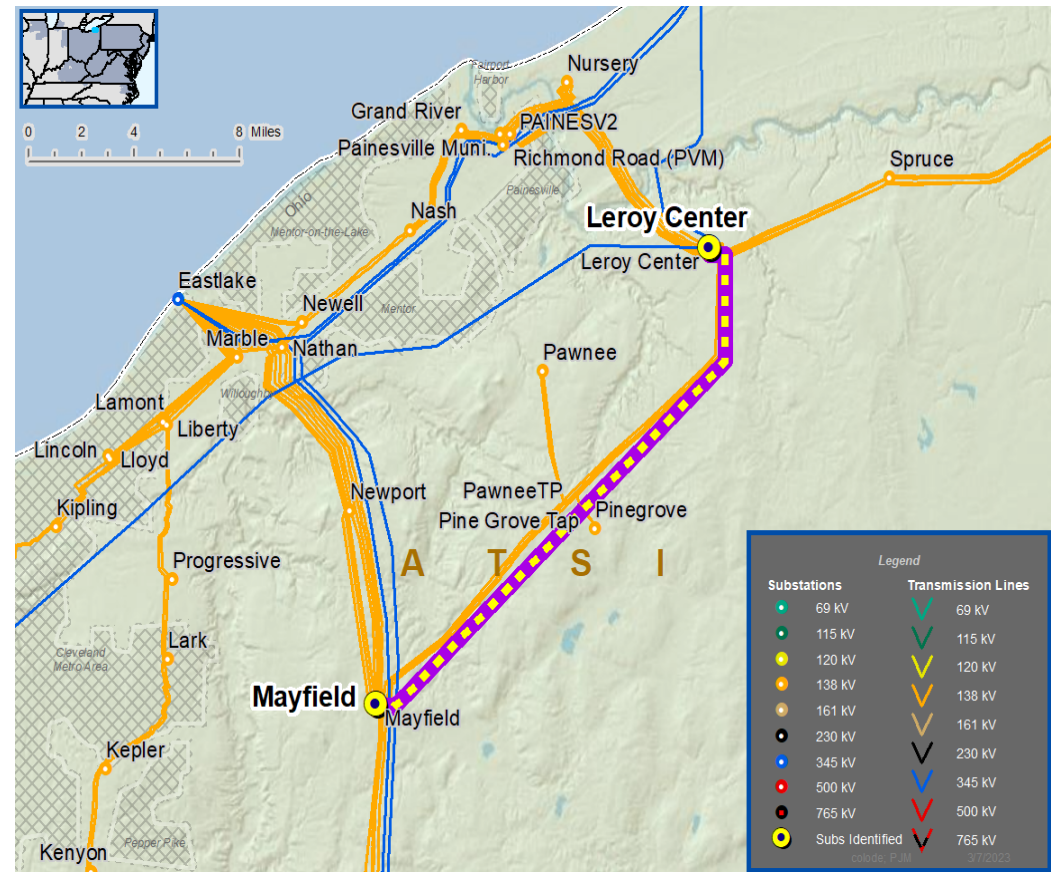



## ATSI Transmission Zone M-3 Process Leroy Center - Mayfield Q4 138 kV

**Need Number:** ATSI-2022-008  
**Process Stage:** Submission of Supplemental Project for Inclusion in the Local Plan - 7/11/2023  
**Presently Presented:** Need Meeting – 03/18/2022  
 Solution Meeting – 03/17/2023

**Supplemental Project Driver(s):**  
*Equipment Material Condition, Performance, and Risk Infrastructure Resilience*

**Specific Assumption Reference(s):**

Global Factors

- System Reliability and Performance
- Increasing negative trend in maintenance findings
- Age/condition of transmission line conductors and hardware

Line Condition Rebuild/Replacement

- End of Life Methodology

**Problem Statement**

- The Leroy Center – Mayfield Q4 138 kV Line (~16.1 miles) originally constructed mid-1940’s, and all structures are similar vintage:
  - 54 of 119 structures inspected had measurable cold end attachment plate wear with instances of mounting holes being 75% worn.
- Age/condition of transmission line conductors and hardware (mid 1940s).

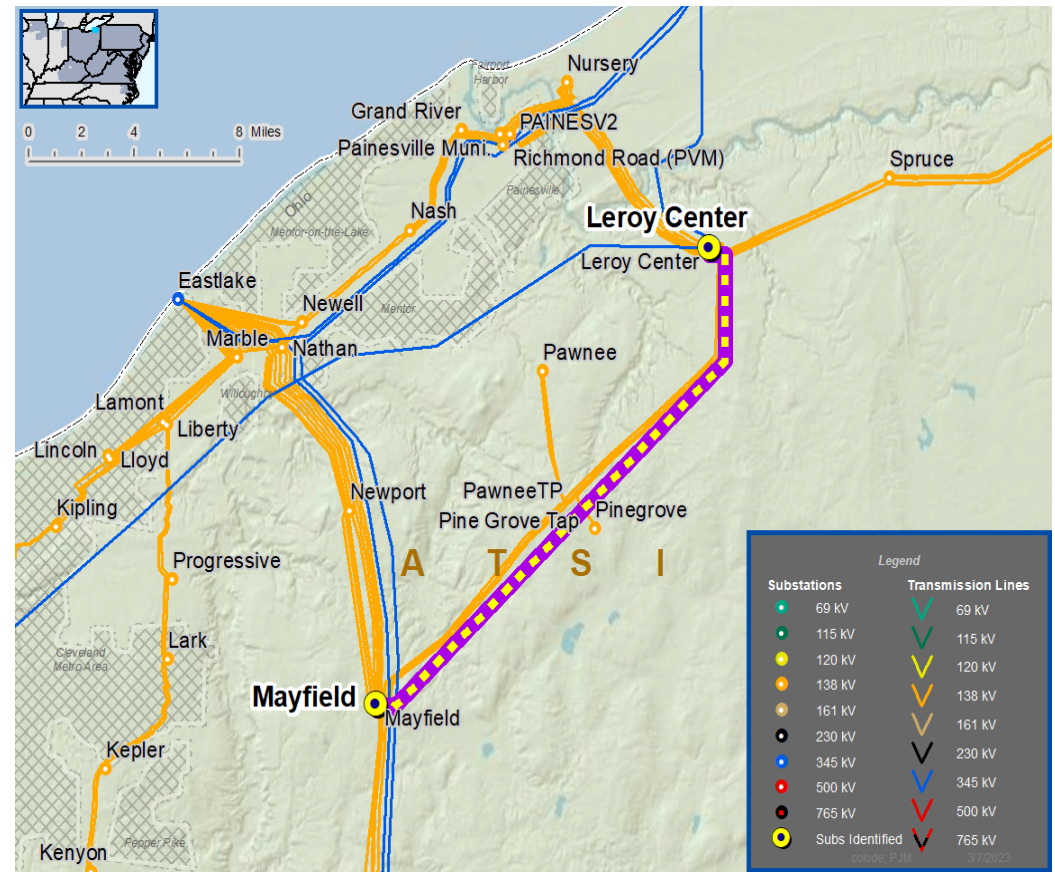



## ATSI Transmission Zone M-3 Process Leroy Center - Mayfield Q4 138 kV

**Need Number:** ATSI-2022-008  
**Process Stage:** Submission of Supplemental Project for Inclusion in the Local Plan – 7/11/2023

**Selected Solution:**

- Reconductor approximately 16.1 miles of the Leroy Center – Mayfield Q4 138 kV Line with 336 ACSS. Replace tower structures, insulators and hardware as needed to address condition items and support new conductor.
- Revise relay settings at Mayfield, Leroy Center, and Pinegrove

**Transmission Line Ratings:**

Leroy Center – Mayfield Q4 138 kV Line

- Before Proposed Solution: 148 MVA SN/ 151 MVA SE
- After Proposed Solution: 252 MVA SN / 291 MVA SE

**Estimated Project Cost:** \$33.5M

**Projected In-Service:** 03/01/2027

**Supplemental Project ID:** s2925

**Model:** 2020 Series 2025 Summer RTEP 50/50

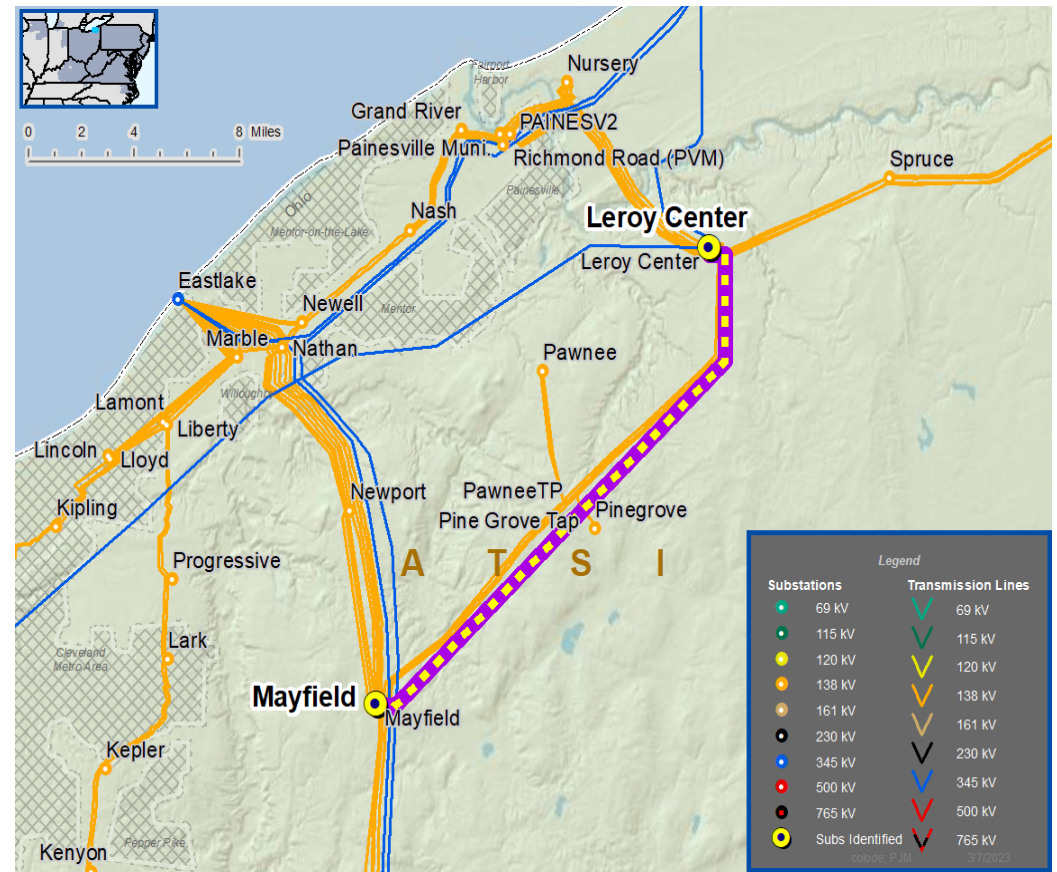





## ATSI Transmission Zone M-3 Process Shenango 345/138 kV Transformers No. 1 and No. 2

**Need Number:** ATSI-2021-024  
**Process Stage:** Submission of Supplemental Project for Inclusion in the Local Plan - 7/11/2023  
**Previously Presented:** Need Meeting – 10/15/2021  
 Solution Meeting – 03/17/2023

**Supplemental Project Driver(s):**  
*Equipment Material Condition, Performance and Risk  
 Infrastructure Resilience*

**Specific Assumption Reference(s):**

Global Factors

- System Reliability and Performance
- Substation/line Equipment Limits

**Substation Equipment Replacement**

- Circuit breakers and other fault interrupting devices
- Switches and relays

**Problem Statement**

- The existing protection scheme on the Shenango 345/138 kV Transformers No. 1 and No. 2 is sensitive to neutral overcurrent inrush, which may cause unnecessary trips.
- Transformer circuit ratings are limited by disconnect switches, CT's, breakers, and substation conductor.
- Approximately 1154 customers and 400 MVA of load served
- Since 2017, Shenango 138 kV lines had eight (8) sustained outages

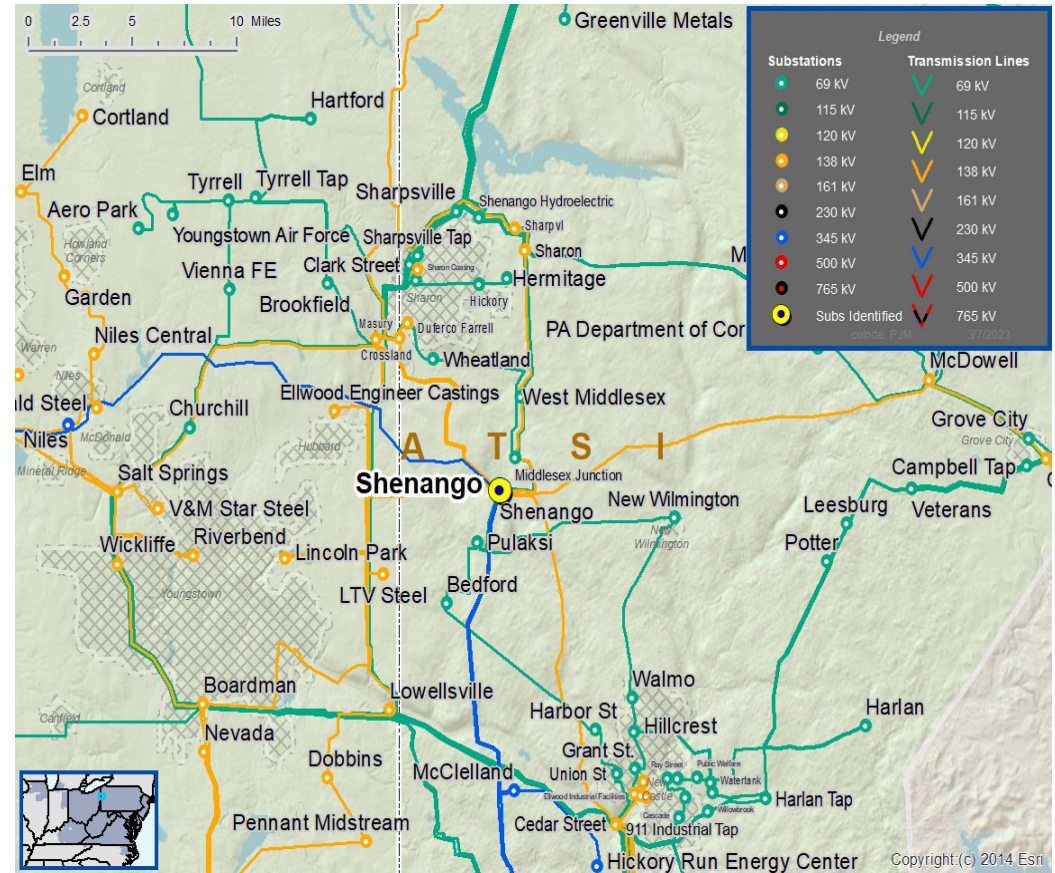





## ATSI Transmission Zone M-3 Process Shenango 345/138 kV Transformers No. 1 and No. 2

**Need Number:** ATSI-2021-024  
**Process Stage:** Submission of Supplemental Project for Inclusion in the Local Plan - 7/11/2023

**Selected Solution:**

**Shenango Sub – Update TR No 1 and TR No 2 Relaying**

- TR No 1 (345/138 kV):
  - Replace 345/138 kV transformer grounding relay with SEL-587
  - Replace 138 kV disconnect switch D1, D3, D4, D5 & D7 and breaker B2 with 3000A equipment.
  - Replace BFT relaying for breakers B2 and B6 with SEL-451
- TR No 2 (345/138 kV):
  - Replace 345/138 kV transformer grounding relay with SEL-587
  - Replace 138 kV disconnect switch D63, D65, D66, D67 & D69 with 3000A equipment.
  - Replace conductor from transformer bushing to disconnect switch
  - Modify relaying settings

**Transmission Transformer Ratings:**

- TR No 1 (345/138KV):
  - Before Proposed Solution: 548 MVA SN / 688 MVA SSTE / 721 MVA WN / 826 MVA WSTE
  - After Proposed Solution: 623 MVA SN / 710 MVA SSTE / 768 MVA WN / 837 MVA WSTE
- TR No 2 (345/138KV):
  - Before Proposed Solution: 548 MVA SN / 659 MVA SSTE / 679 MVA WN / 753 MVA WE
  - After Proposed Solution: 620 MVA SN / 710 MVA SSTE / 743 MVA WN / 834 MVA WSTE

**Estimated Project Cost:** \$1.4 M  
**Projected In-Service:** 12/30/2023  
**Supplemental Project ID:** s2926  
**Model:** 2020 Series RTEP Model for 2025 Summer

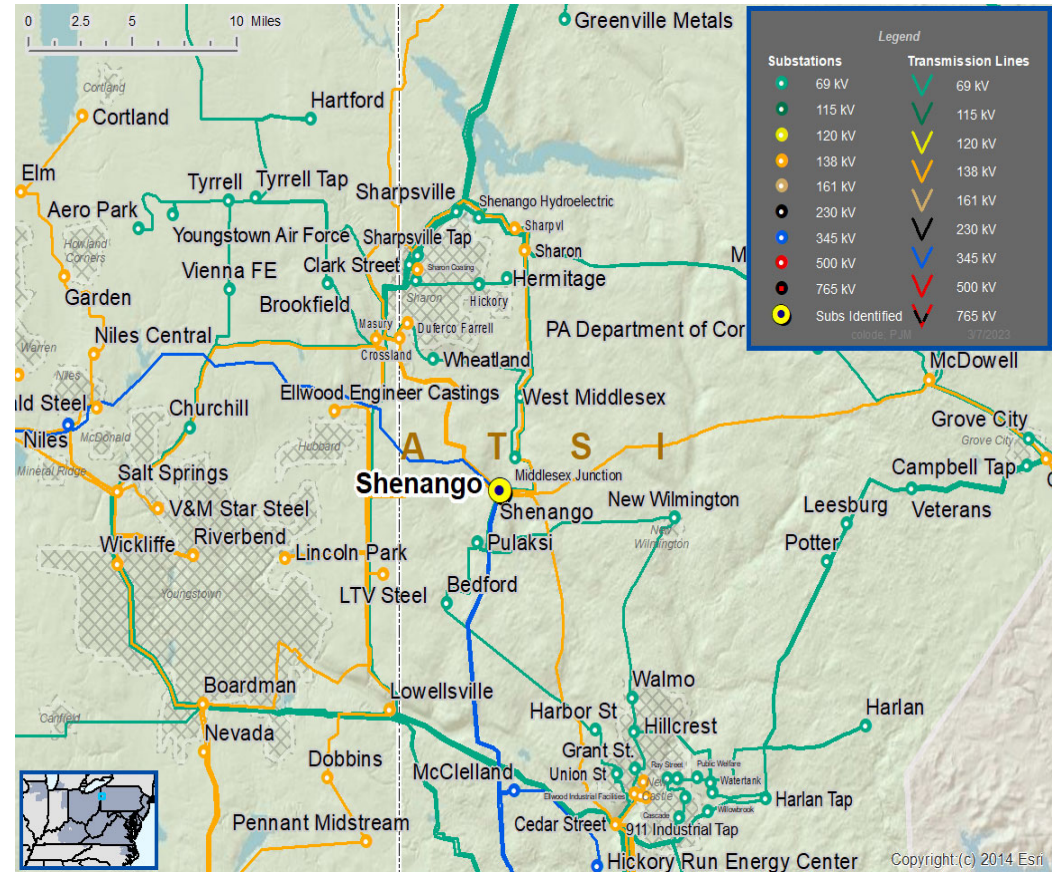



## ATSI Transmission Zone M-3 Process Carlisle-Wellington 69 kV Line

**Need Number:** ATSI-2018-018 (s1803)

**Process Stage:** Submission of Supplemental Project for Inclusion in the Local Plan - 7/11/2023

**Previously Presented:** Need Meeting – 09/28/2018  
Solution Meeting – 10/26/2018  
Re-present Solution Meeting – 3/17/2023

**Supplemental Project Driver(s):**  
*Equipment Material Condition, Performance and Risk*

**Specific Assumption Reference(s)**

Line Condition Rebuild / Replacement

Assessment of existing transmission lines for equipment characteristics that are at, or beyond their existing service life, or contain components that are obsolete.

- Aged or deteriorated wood pole transmission line structures.
- Negatively impact customer outage frequency and/or durations.
- Demonstrate an increasing trend in maintenance findings and/or costs

**Problem Statement**

Carlisle-Wellington 69 kV Condition Assessment (Approximately 29 miles)

- Identified obsolete and deteriorated equipment.
- Multiple transmission delivery points (9) impacted.

Continued on next slide...

SRRETP Committee: Western – FirstEnergy Supplemental

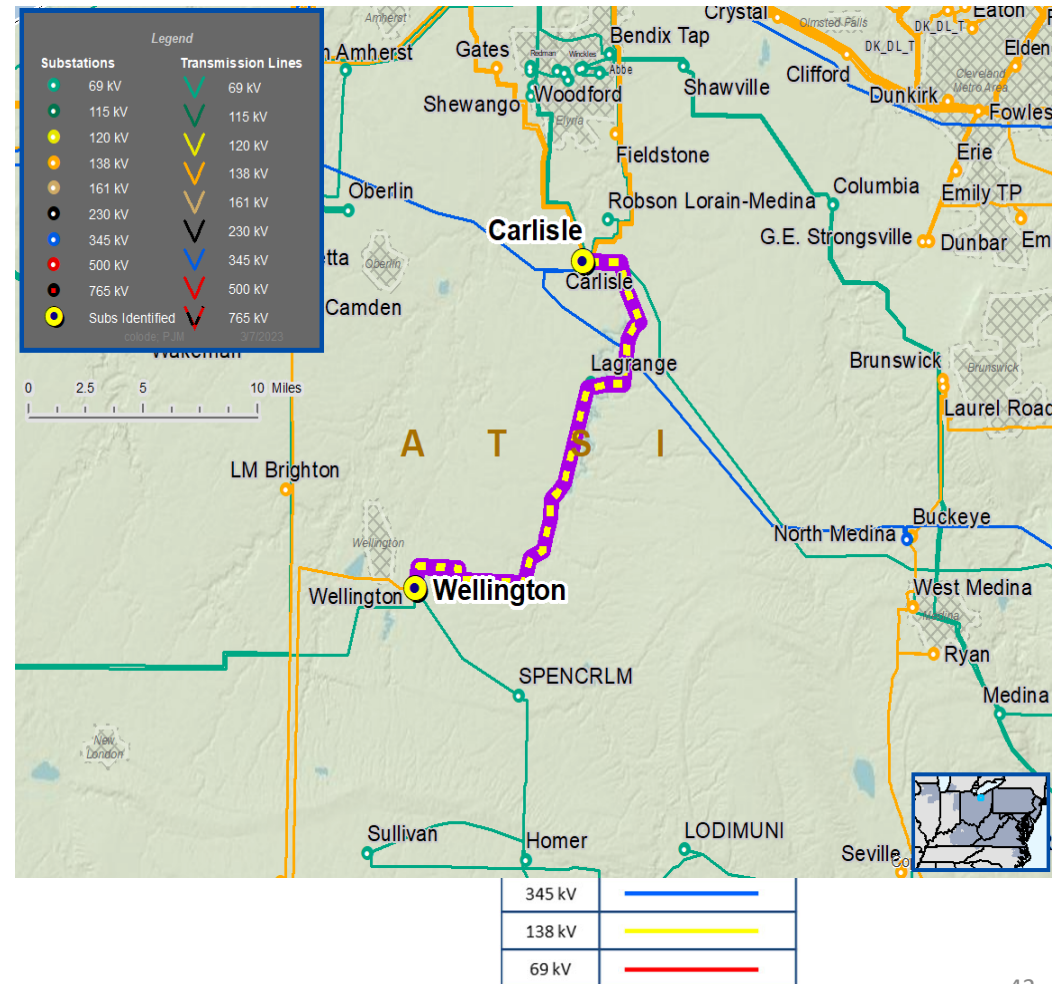



## ATSI Transmission Zone M-3 Process Carlisle-Wellington 69 kV Line

**Need Number:** ATSI-2018-018 (s1803)

**Process Stage:** Submission of Supplemental Project for Inclusion in the Local Plan - 7/11/2023

### Problem Statement

Carlisle-Wellington 69 kV Condition Assessment Update (Approximately 22.4 miles)

- From Carlisle substation to structure #19 (Larson tap)
  - Pole Condition failure 69%; Condition plus age failure 83%.
- From Wellington substation to structure #69 (excluding Litchfield tap)
  - Pole condition failure 20%; Condition plus age failure 91%.
- From Larson tap (structure #19) to Litchfield tap (structure #69)
  - Pole condition failure 16%; Condition plus age 33%;
- Note: condition failures identified would impact the integrity of the structure such as cracking/splitting, large holes due to woodpecker damage, sign of pole rot, damage to or splitting of bayonets or crossarms, etc.
- Outage history from 2017-2023YTD: sixteen total outages; seven momentary and nine sustained outages with average sustained outage duration of 29 minutes
- Approximately 26,075 customers and 58 MW of load impacted

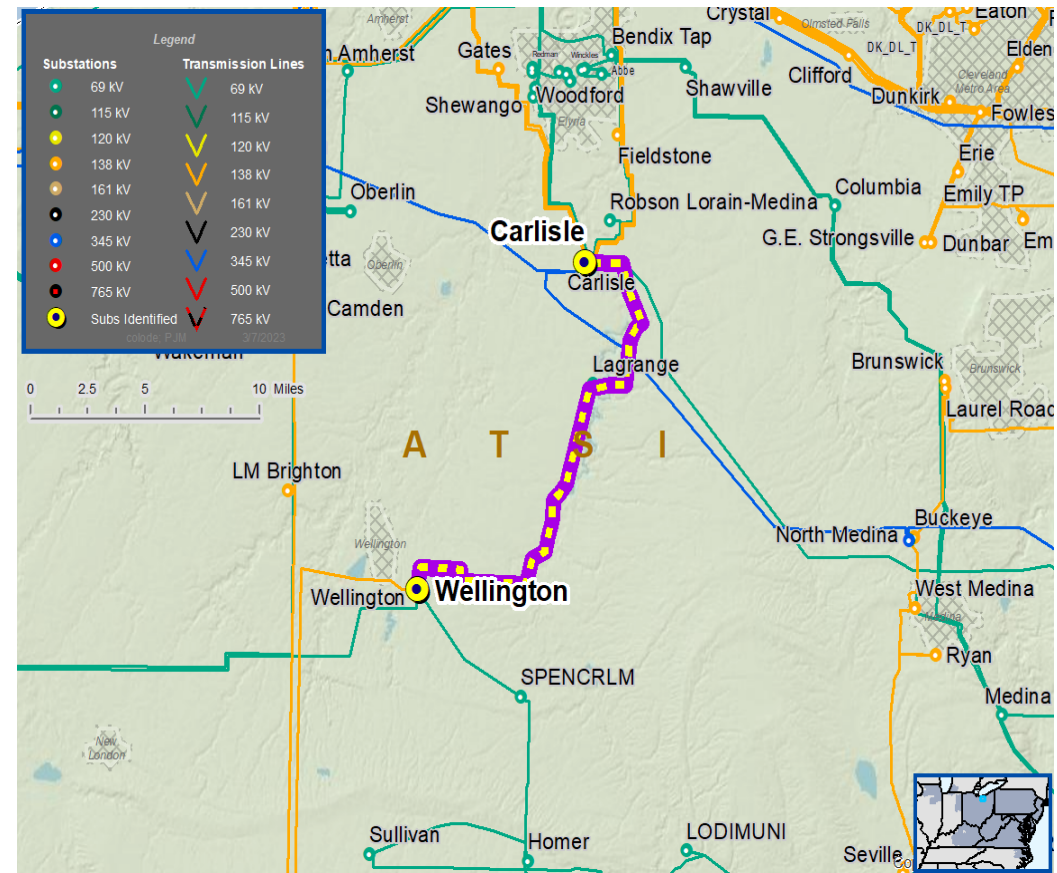

Continued on next slide...

SRRTEP Committee: Western – FirstEnergy Supplemental



**Need Number:** ATSI-2018-018 (s1803)  
**Process Stage:** Submission of Supplemental Project for Inclusion in the Local Plan - 7/11/2023

**Selected Solution:**

Carlisle-Wellington 69 kV Line

- Rebuild the section of line from structure #70 to structure #19 including the loop to the Carlisle substation, ~3.8 miles using 556 kcmil 26/7 ACSR conductor
- Rebuild the section of line from the Wellington substation to structure #67 (excluding Litchfield tap), ~4.8 miles using 556 Kcmil 26/7 ACSR conductor
- Rehab the section of the line from the Larson tap (structure #19) to the Litchfield tap (structure #69), ~13.8 miles using existing conductor will be used. The rehab will include the Webster and Grafton Muni taps.
- Replace line switches A-37, A-40, A-41, A-48, A-49, A-50, A-69, and A-70
- Install underground fiber cable from Carlisle substation to Wellington substation
- At Carlisle replace relays and controls.
- At Wellington, replace Disconnect D-33, D-35 & A-36.
- At Lagrange reconductor main bus.

Continued next slide...

## ATSI Transmission Zone M-3 Process Carlisle-Wellington 69 kV Line

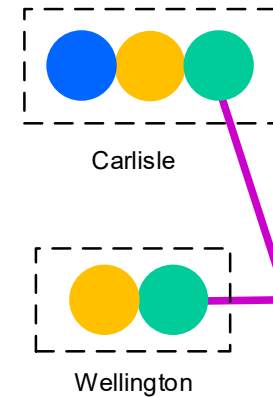

Legend	
500 kV	
345 kV	
138 kV	
69 kV	
34.5 kV	
23 kV	
New	





## ATSI Transmission Zone M-3 Process Carlisle-Wellington 69 kV Line

- Need Number:** ATSI-2018-018 (s1803)
- Process Stage:** Submission of Supplemental Project for Inclusion in the Local Plan - 7/11/2023
- Selected Solution:**
- Transmission Line Ratings:**
- Carlisle-Wellington 69 kV Line:
- Carlisle-Carlisle tap section:
    - Existing line rating: 108 MVA SN / 108 MVA SE /118 MVA SLD
    - New line rating: 111 MVA SN / 134 MVA SE /151 MVA SLD
  - Carlisle tap-Larson tap section:
    - Existing line rating: 76 MVA SN / 92 MVA SE /104MVA SLD
    - New line rating: 111 MVA SN / 134 MVA SE /151 MVA SLD
  - Wellington-Wellington Muni section:
    - Existing line rating: 76 MVA SN / 92 MVA SE /95 MVA SLD
    - New line rating: 111 MVA SN / 134 MVA SE /151 MVA SLD
  - Wellington Muni-LMREC Central section:
    - Existing line rating: 76 MVA SN / 92 MVA SE /104 MVA SLD
    - New line rating: 111 MVA SN / 134 MVA SE /151 MVA SLD
  - LMREC Central-Litchfield tap section:
    - Existing line rating: 76 MVA SN / 92 MVA SE /104 MVA SLD
    - New line rating: 111 MVA SN / 134 MVA SE /151 MVA SLD
- Estimated Project Cost:** \$18.8M  
**Supplemental Project ID:** s1803  
**Projected IS Date:** 12/4/2023

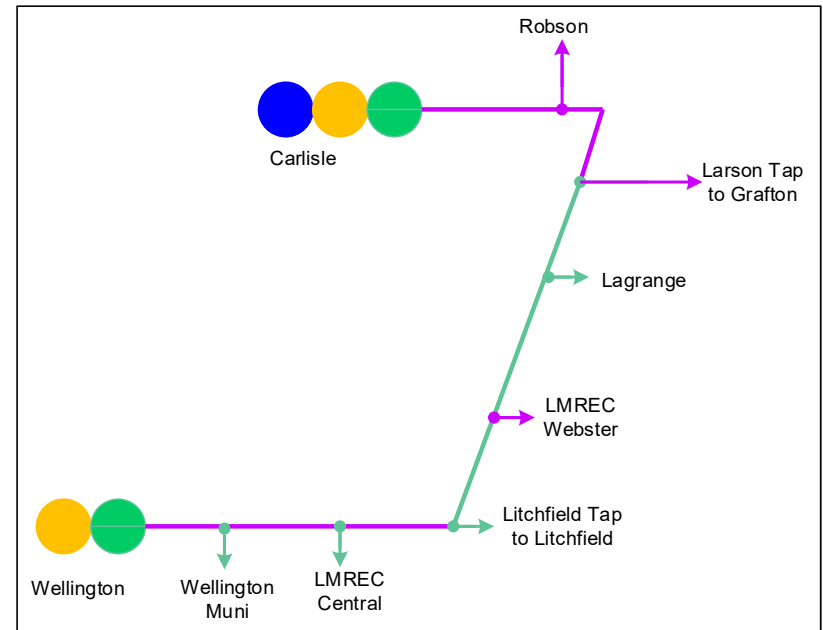

Legend	
500 kV	
345 kV	
138 kV	
69 kV	
34.5 kV	
23 kV	
New	



## ATSI Transmission Zone M-3 Process Carol 138-69 kV Switching Station

**Need Number:** ATSI-2021-004  
**Process Stage:** Submission of Supplemental Project for Inclusion in the Local Plan – 9/21/2023  
**Previously Presented:** Need Meeting – 8/31/2018  
 Solution Meeting – 9/28/2018  
 Re-Present Solution Meeting – 4/21/2023

**Supplemental Project Driver(s):**  
*Operational Flexibility and Efficiency*

**Specific Assumption Reference(s):**

Global Factors

- Load Loss
- System Reliability and Performance

**Problem Statement**

- Improve operational flexibility during maintenance and restoration efforts.
- Reduce amount of potential local load loss (Approximately 35 MWs worse case) under multiple (P1) contingency conditions on the 69 kV system.
  - Loss of the Cedar Street-Cascade (Walmo) 69 kV normally open radial line
- Improve relay coordination and network normally open 69 kV lines.
- Approximately 21,000 customers and radial load of 86 MWs at risk in the area.

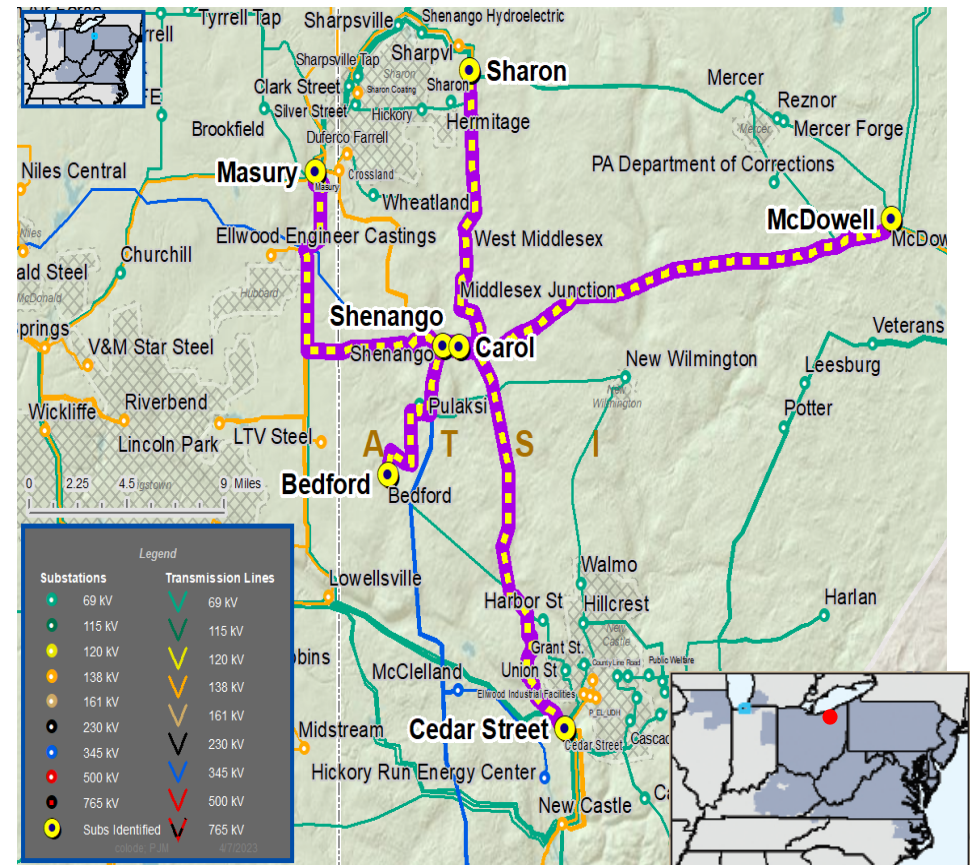



## ATSI Transmission Zone M-3 Process Carol 138-69 kV Switching Station

**Need Number:** ATSI-2021-004  
**Process Stage:** Submission of Supplemental Project for Inclusion in the Local Plan – 9/21/2023

**Selected Solution:**  
 Shenango substation is built in a floodplain with significant challenges, including permitting and environmental mitigation costs.

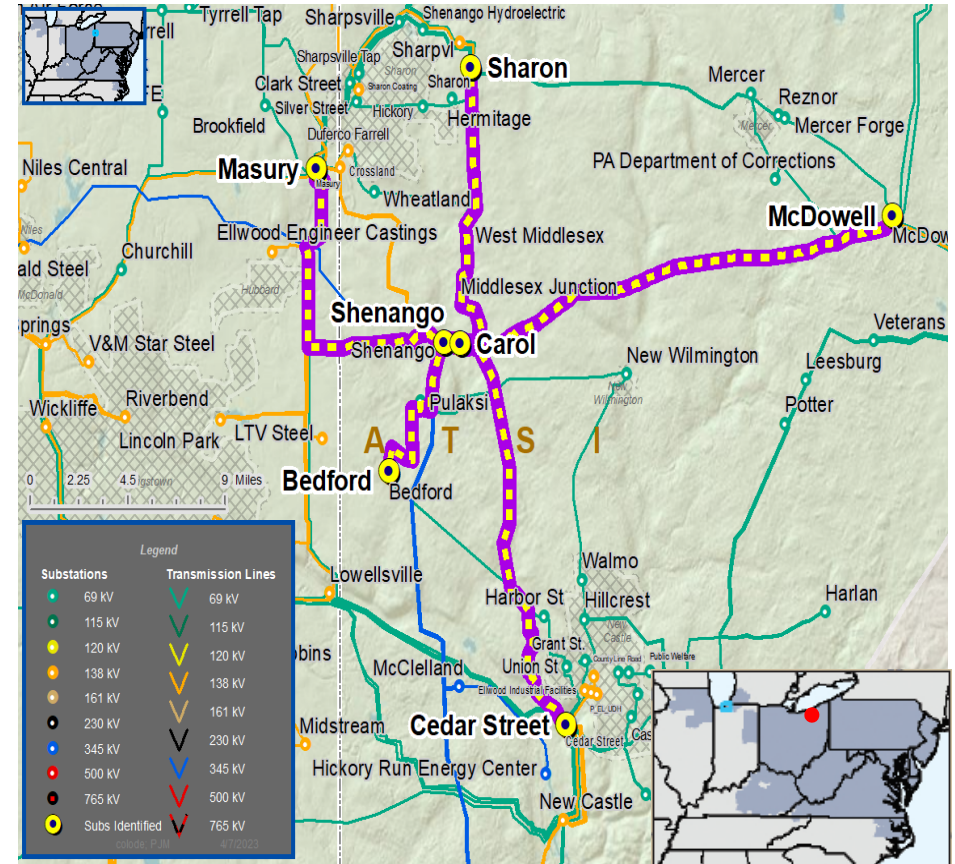

Continued on next slide...



## ATSI Transmission Zone M-3 Process Carol 138-69 kV Switching Station

### CAROL

**Need Number:** ATSI-2021-004  
**Process Stage:** Submission of Supplemental Project for Inclusion in the Local Plan – 9/21/2023

**Selected Solution:**

- Carol 138-69 kV Switching Substation
- Construct a new 138 kV 6-breaker ring bus substation near the Shenango Substation (Future 12-Breaker Breaker-and-a-Half).
- Loop in the Cedar Street-Shenango and Shenango-McDowell 138 kV lines into the new substation.
- Construct a new 69 kV six-breaker ring bus adjacent to the new 138 kV substation.
- Loop in the Cedar Street-Masury-Sharon 69 kV line, undo the six-wire configuration between structures #169 and #216 to create four new 69 kV circuits out of the new Carol 69 kV Substation.
- Rebuild and reconductor approximately 3.0 miles
- Install (2) 138-69 kV 100/134 MVA transformers
- Install new control building

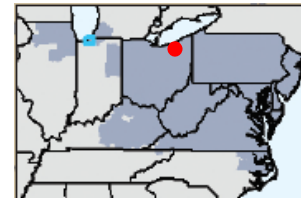
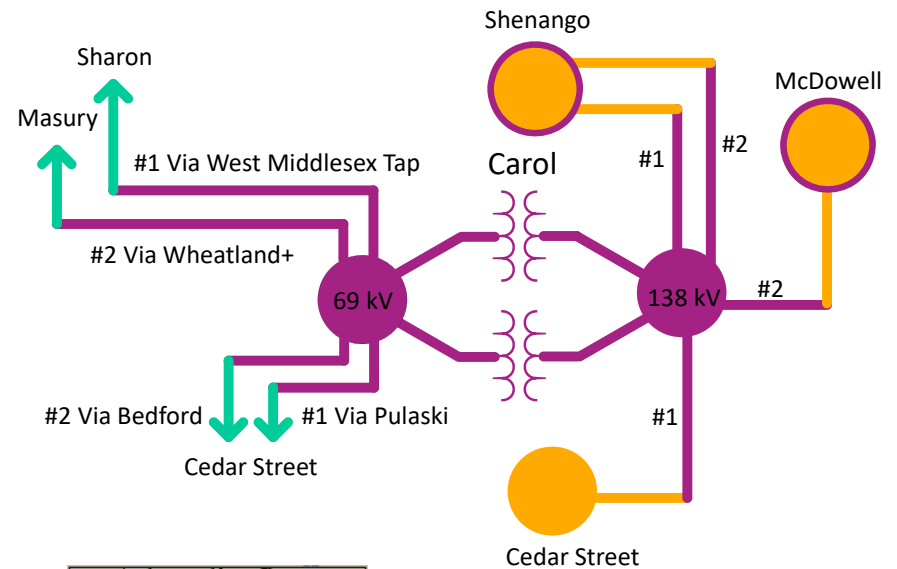

Legend	
345 kV	
138 kV	
69 kV	

Continued on next slide...





**Need Number:** ATSI-2021-004  
**Process Stage:** Submission of Supplemental Project for Inclusion in the Local Plan - 9/21/2023

**Selected Solution:**

- At Masury:
  - Replace Y-188 (B17) 69 kV line relaying and control with standard relay panel
- At Sharon:
  - Replace Y-188/Y-303 (B6) 69 kV line relaying and control with standard relay panel
  - Replace the limiting disconnect switch
- At Shenango:
  - Replace 138 kV breaker (B48) and line relaying
  - Replace two 138 kV breaker disconnect switches (D37 & D43)
  - Upgrade the terminal equipment (line drops) to exceed the TL rating
- At McDowell:
  - Upgrade the terminal equipment (substation conductor) to exceed the TL rating

## ATSI Transmission Zone M-3 Process Carol 138-69 kV Switching Station CAROL

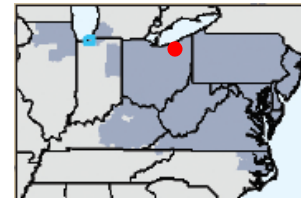
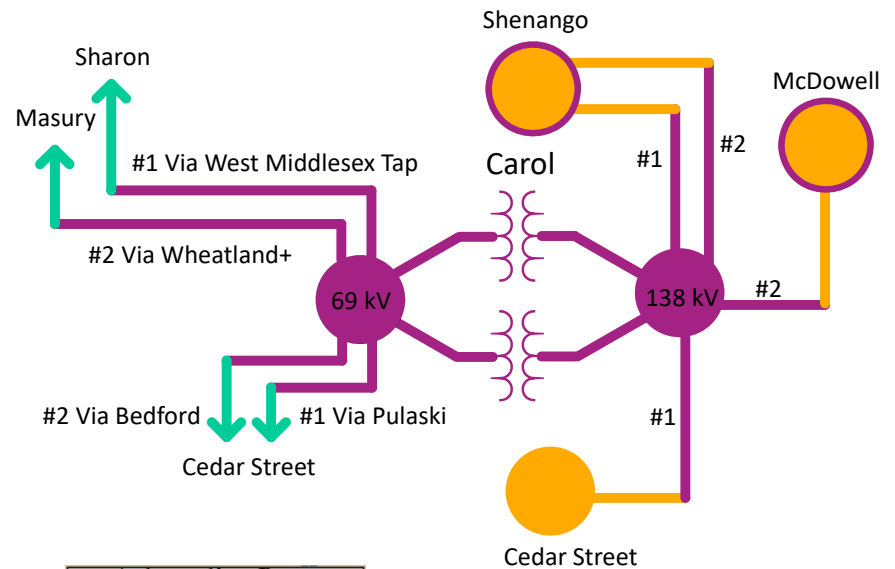

Legend	
345 kV	<span style="color: blue;">—</span>
138 kV	<span style="color: yellow;">—</span>
69 kV	<span style="color: red;">—</span>

Continued on next slide...



**Need Number:** ATSI-2021-004  
**Process Stage:** Submission of Supplemental Project for Inclusion in the Local Plan - 9/21/2023

**Selected Solution:**

**Transmission Line Ratings:**

**Existing Lines:**

- Cedar Street-Shenango 138 kV Line:
  - SN: 278 MVA SE: 339 MVA WN: 315 MVA WE: 401 MVA
- McDowell-Shenango 138 kV Line:
  - SN: 265 MVA SE: 309 MVA WN: 309 MVA WE: 309 MVA
- Cedar Street-Masury-Sharon 69 kV Line:
  - SN: 94 MVA SE: 113 MVA

## ATSI Transmission Zone M-3 Process Carol 138-69 kV Switching Station CAROL

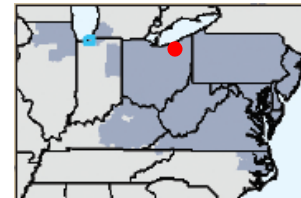
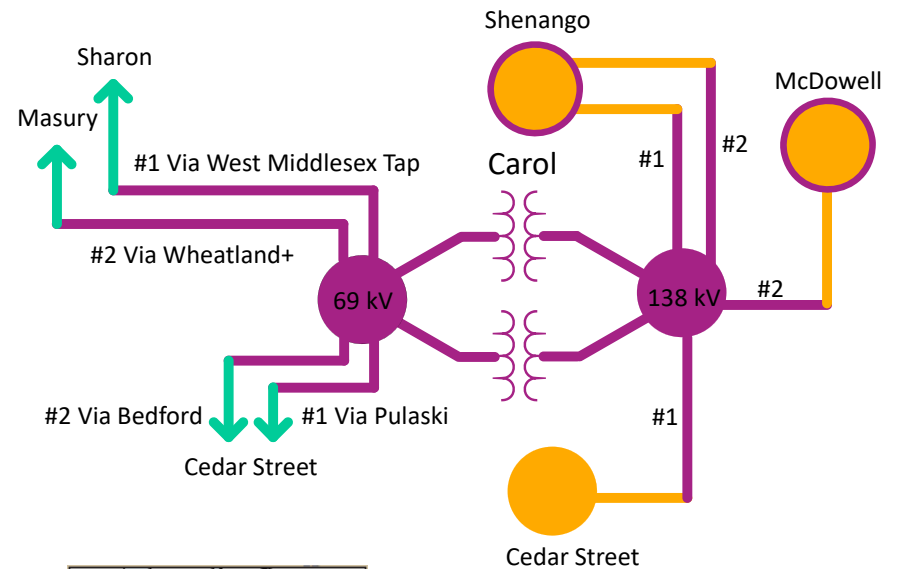

Legend	
345 kV	
138 kV	
69 kV	

Continued on next slide...



# ATSI Transmission Zone M-3 Process Carol 138-69 kV Switching Station

## CAROL

**Need Number:** ATSI-2021-004  
**Process Stage:** Submission of Supplemental Project for Inclusion in the Local Plan– 9/21/2023

**Selected Solution:**

**Transmission Line Ratings:**

**New Lines:**

- Carol-Sharon 69 kV Line:
  - SN: 100 MVA SE: 121 MVA WN: 113 MVA WE: 143 MVA
- Carol- Masury 69 kV Line:
  - SN: 80 MVA SE: 96 MVA WN: 90 MVA WE: 114 MVA
- Carol- Pulaski (#1) 69 kV Line (Cedar Street):
  - SN: 80 MVA SE: 96 MVA WN: 90 MVA WE: 114 MVA
- Carol- Bedford (#2) 69 kV Line (Cedar Street):
  - SN: 94 MVA SE: 113 MVA WN: 105 MVA WE: 133 MVA
- Carol-Shenango (#1) 138 kV Line:
  - SN: 278 MVA SE: 339 MVA WN: 315 MVA WE: 401 MVA
- Carol-Cedar St (#1) 138 kV Line:
  - SN: 278 MVA SE: 339 MVA WN: 315 MVA WE: 401 MVA
- Carol-Shenango (#2) 138 kV Line:
  - SN: 278 MVA SE: 339 MVA WN: 315 MVA WE: 401 MVA
- Carol-McDowell (#2) 138 kV Line:
  - SN: 278 MVA SE: 339 MVA WN: 315 MVA WE: 401 MVA

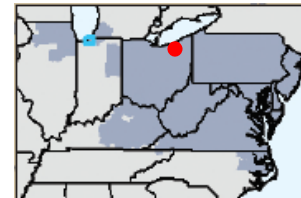
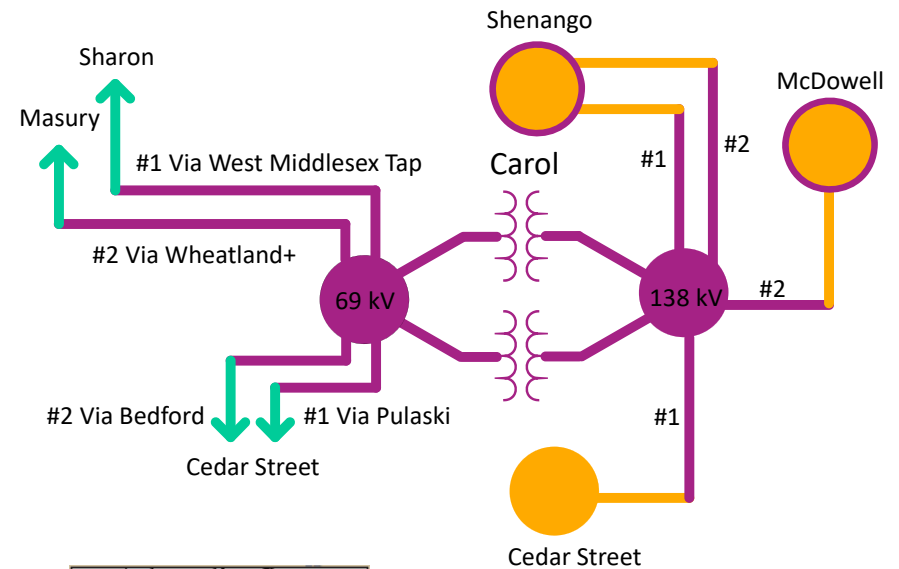

Legend	
345 kV	
138 kV	
69 kV	

Continued on next slide...



**Need Number:** ATSI-2021-004  
**Process Stage:** Submission of Supplemental Project for Inclusion in the Local Plan – 9/21/2023

**Selected Solution:**

**Alternatives Considered:** Network radial 69 kV system by constructing two double circuit 477 ACSR 69 kV lines (~ 1.2 miles) to create four (4) new 69 kV circuits from the new Shenango 69 kV station. Install two (2) 138-69 kV transformers at Shenango. Expand Shenango substation to create a six (6) breaker 69 kV ring bus.

**Estimated Project Cost:** \$45M  
**Project IS Date:** 12/1/2025  
**Model:** 2022 RTEP model for 2027 Summer (50/50) Case  
**Status:** Pre-Engineering  
**Supplemental Project ID:** s1712

## ATSI Transmission Zone M-3 Process Carol 138-69 kV Switching Station CAROL

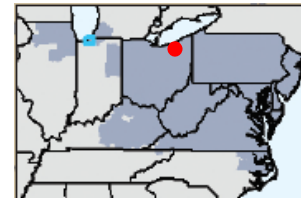
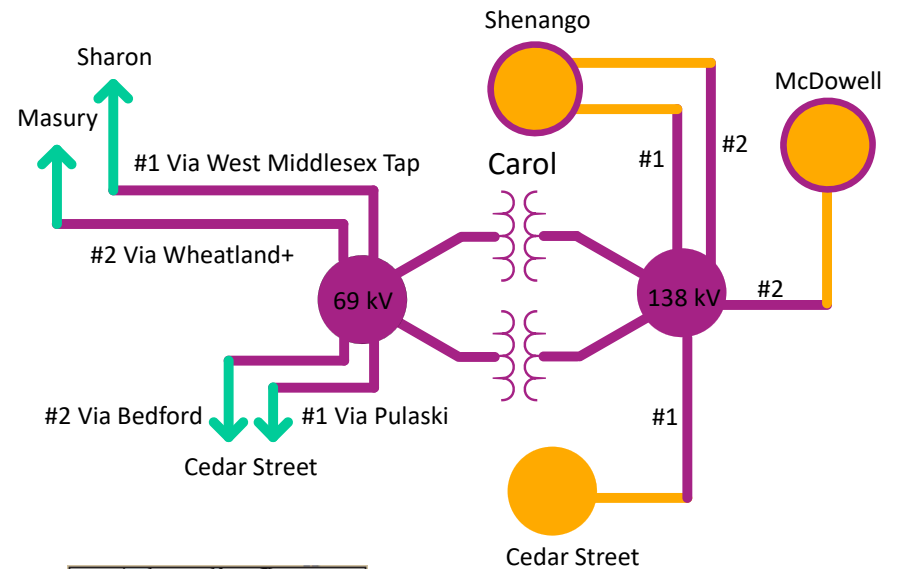

Legend	
345 kV	
138 kV	
69 kV	





## ATSI Transmission Zone M-3 Process Maysville 69 kV Area

**Need Number:** ATSI-2021-005  
**Process Stage:** Submission of Supplemental Project for Inclusion in the Local – 9/21/2023  
**Previously Presented:** Need Meeting – 10/15/2021  
 Solution Meeting – 4/21/2023

**Supplemental Project Driver(s):**  
*Operational Flexibility and Efficiency*  
*Equipment Material Condition, Performance and Risk*

### Specific Assumption Reference(s)

#### Global Considerations

- System Reliability and Performance
- Substation/line equipment limits
- Reliability of Non-BES Facilities
- Load at risk in planning and operational scenarios.
- Load and/or customers at risk on single transmission lines

#### Network Radial Lines

- Load at risk and/or customers affected
- Proximity to other networked facilities

#### Build New Transmission Line

- Network radial lines

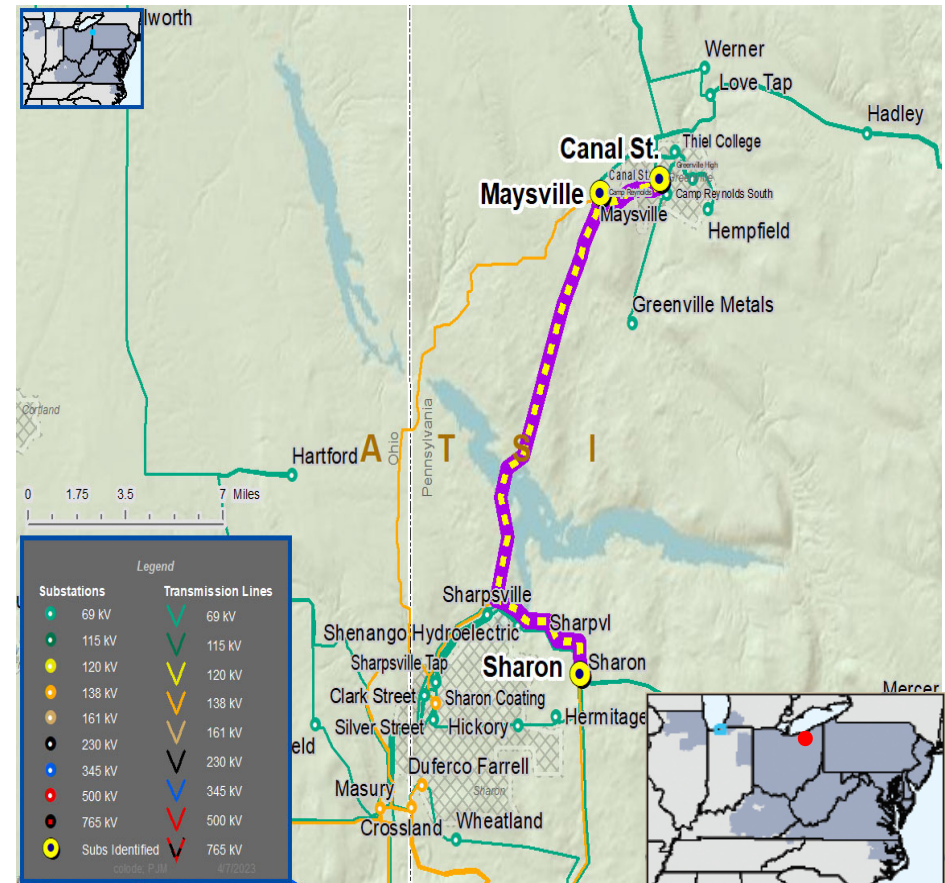



## ATSI Transmission Zone M-3 Process Maysville 69 kV Area

**Need Number:** ATSI-2021-005  
**Process Stage:** Submission of Supplemental Project for Inclusion in the Local Plan – 9/21/2023

### Problem Statement

Canal (Maysville) 69 kV Line

- The Canal (Maysville) Y-79 69 kV Line serves 14 MW and 6,500 customers on a ~3.6 mile radial
- A P1-2 contingency for the loss of the Canal (Maysville) Y-79 69 kV Line will outage roughly 14 MW and 6,500 customers
- The Canal (Maysville) Y-79 69 kV Line has experienced 1 sustained outage the past 5 years
- The Maysville-Sharon Y-301 69 kV Line serves 18 MW and 2,600 customers at two delivery points served on a ~2.7-mile tap
- A P1-2 contingency for the loss of the Maysville-Sharon Y-301 69 kV Line will outage roughly 18 MW and 2,600 customers
- The Maysville-Sharon Y-301 69 kV Line has experienced 4 sustained outages the past 5 years

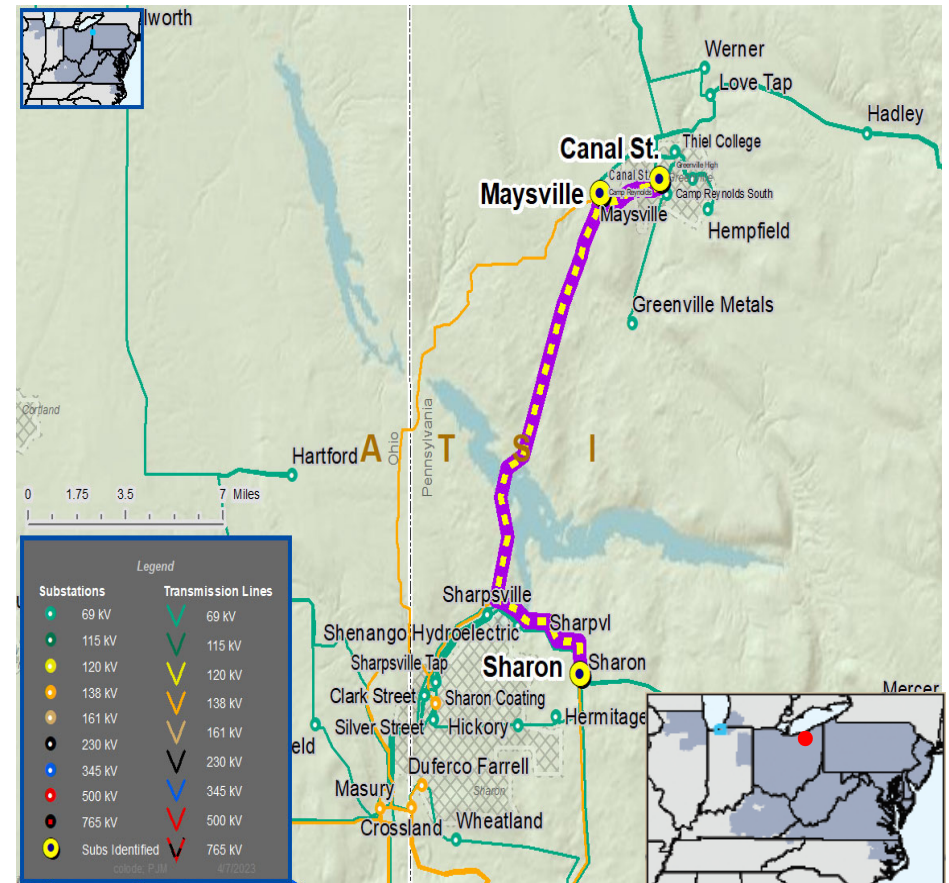



**Need Number:** ATSI-2021-005  
**Process Stage:** Submission of Supplemental Project for Inclusion in the Local Plan – 9/21/2023

**Selected Solution:**

- Remove switches A118 and A119 on the Maysville-Sharon Y-301 69 kV Line
- De-energize roughly 3.6 miles of the Maysville-Sharon 69 kV line from Maysville to the Camp Reynolds tap location.
- Remove switches A2153, A23, A2151, A260, A261 and A2152 at Greenville
- Build approximately 3.0 mi of 69 kV line connecting the Camp Reynolds (near TY19) tap to the Canal Tap (near TY104)
- Add 69 kV line switches with SCADA at Camp Reynolds tap, Greenville Metal tap, and Canal tap
- Add one 69 kV line switch with SCADA at Trinity tap

**Transmission Line Ratings:**

- Maysville-Sharon Y301 69 kV Line
  - Before Proposed Solution: 69 MVA SN / 72 MVA SE
- Canal-Greenville 69 kV Line
  - Before Proposed Solution: 47 MVA SN / 56 MVA SE
- Sharon-Greenville 69 kV Line
  - After Proposed Solution: 47 MVA SN / 56 MVA SE

## ATSI Transmission Zone M-3 Process Maysville 69 kV Area

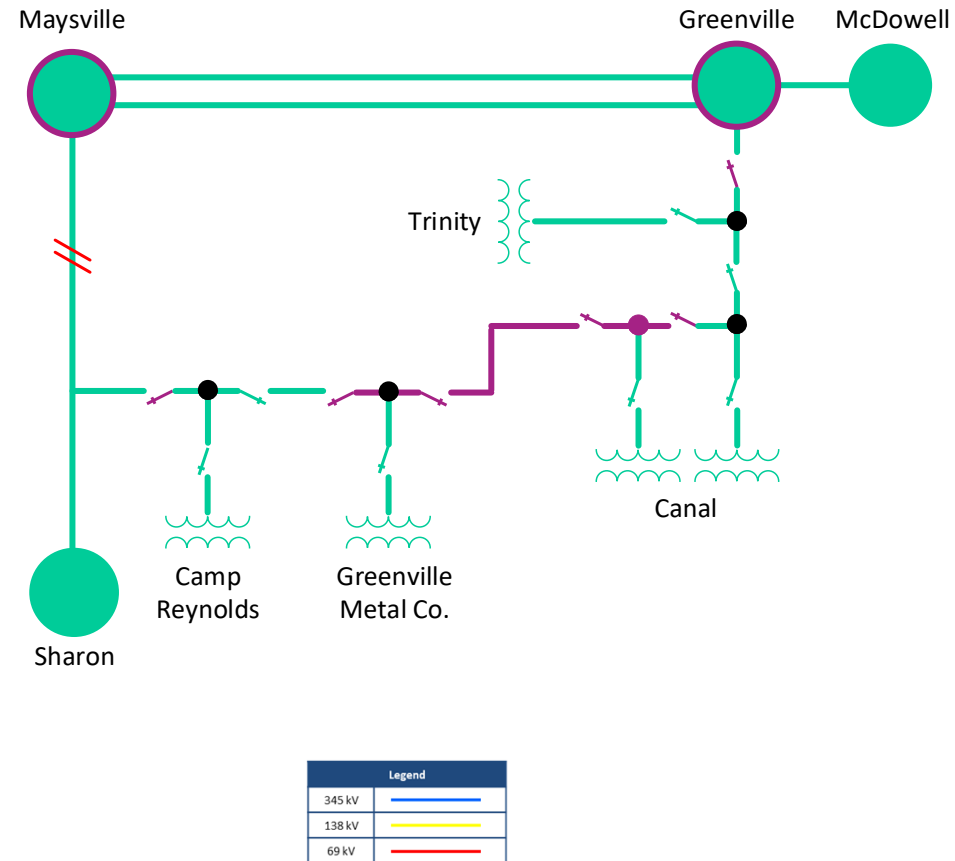



**Need Number:** ATSI-2021-005  
**Process Stage:** Submission of Supplemental Project for Inclusion in the Local Plan – 9/21/2023  
**Estimated Project Cost:** \$12.2 M  
**Projected In-Service:** 6/1/2025  
**Model:** 2020 Series 2025 Summer RTEP 50/50  
**Supplemental Project ID:** s2936

## ATSI Transmission Zone M-3 Process Maysville 69 kV Area

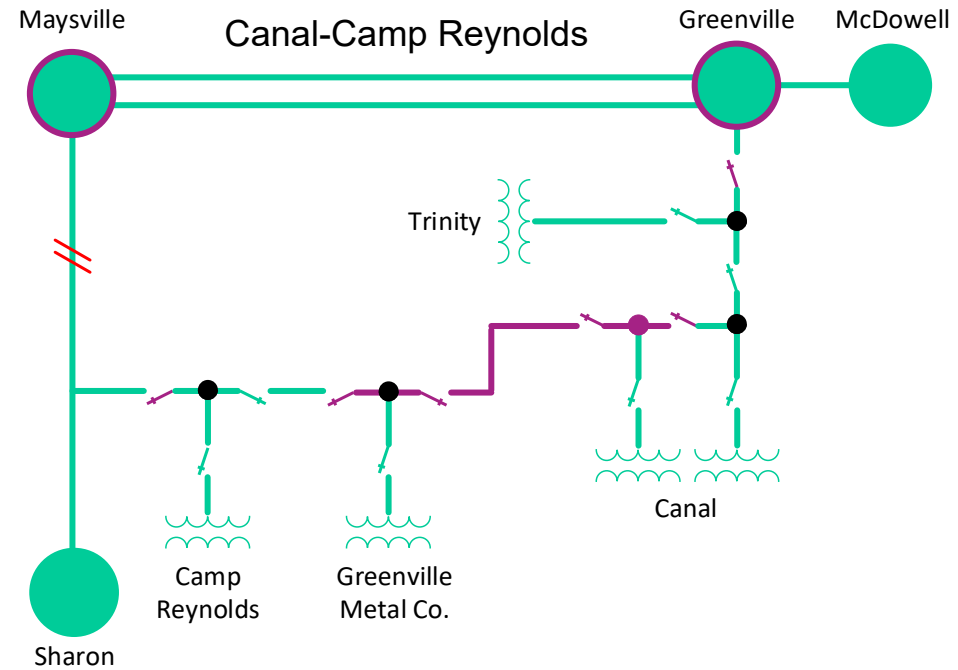

Legend	
345 kV	
138 kV	
69 kV	





## ATSI Transmission Zone M-3 Process Emily-Fox 138 kV Q14 Line

**Need Number:** ATSI-2022-023  
**Process Stage:** Submission of Supplemental Project for Inclusion in the Local Plan – 9/21/2023  
**Previously Presented:** Need Meeting – 09/16/2022  
 Solution Meeting – 4/21/2023

**Supplemental Project Driver(s):**  
*Equipment Material Condition, Performance, and Risk Infrastructure Resilience*

**Specific Assumption Reference(s):**

**Global Factors**

- System Reliability and Performance
- Increase line loading limits
- Age/condition of transmission line conductors
- Line Condition Rebuild/Replacement

**Problem Statement**

- During inspection of the Emily-Fox 138 kV Line (approximately 19 miles), seven (7) wood pole structures failed sound testing and/or decay has been noted, as well as miscellaneous broken insulators, missing or broken grounds, hardware, braces, climbing pegs, etc

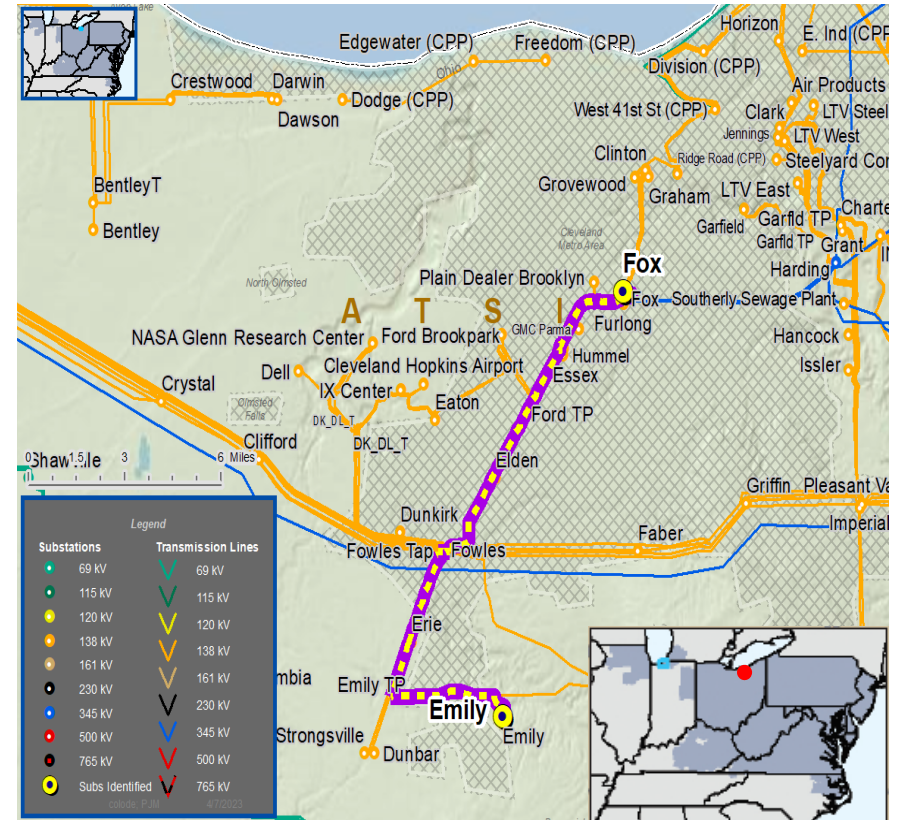



## ATSI Transmission Zone M-3 Process Emily – Fox 138 kV Q14 Line Rehab -Solution

**Need Number:** ATSI-2022-023  
**Process Stage:** Submission of Supplemental Project for Inclusion in the Local Plan – 9/21/2023

### Fowles 138 kV Substation

- Replace existing 500 Cu strain bus at Fowles 138 kV (Emily – Fox 138 kV Line is routed through Fowles 138 kV Station)

### Emily – Fox Q14 138 kV Line

- Replace and upgrade seven (7) wood pole structures on Emily – Fox 138 kV Q14 Line
- Replace damaged and worn insulators on ten (10) additional structures

### Transmission Line Ratings:

- Existing Galaxie – Hummel Tap line section rating: 176 SN / 229 SE / 253 WN / 284 WE
- New Galaxie – Hummel Tap line section rating: 347 SN / 423 SE / 393 WN / 501 WE

**Estimated Project Cost:** \$1.1M  
**Projected In-Service:** 12/31/2023  
**Supplemental Project ID:** s2937

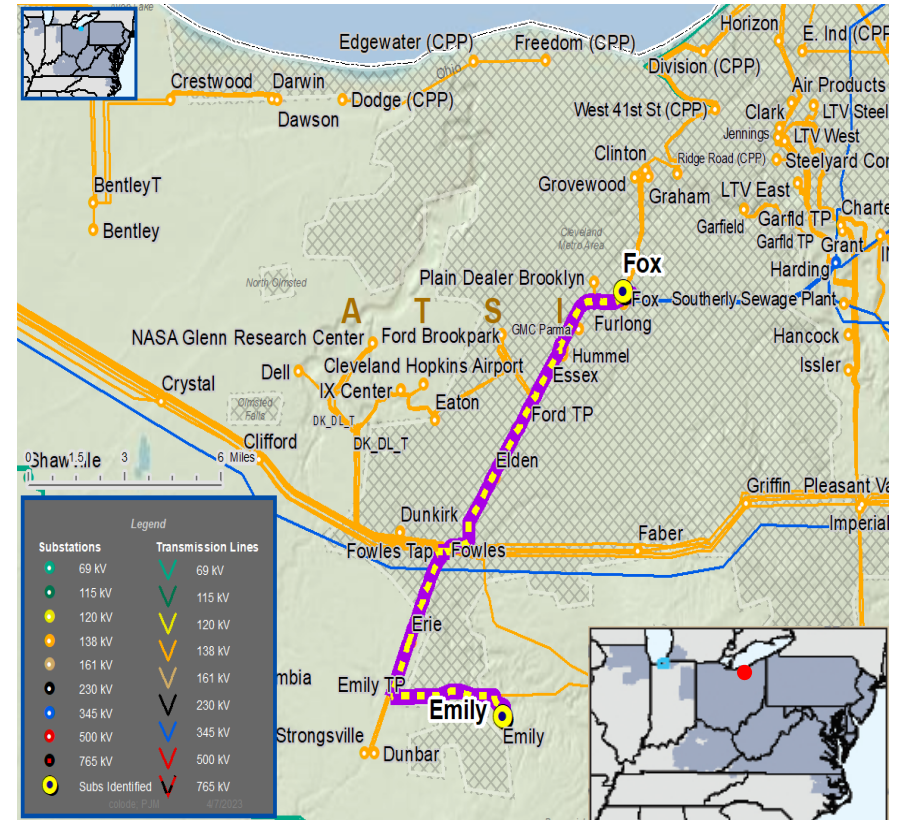



**Need Number:** ATSI-2018-023  
**Process Stage:** Submission of Supplemental Project for Inclusion in the Local Plan - 9/26/2023  
**Previously Presented:** Need Meeting – 11/29/2018  
 Solution Meeting – 02/20/2019

**Project Driver(s):**  
*Operational Flexibility and Efficiency*  
**Infrastructure Resilience**

**Specific Assumption Reference(s)**

- Transmission lines with high loading
- Contingency constrained facilities
- Loading on adjacent facilities
- Accommodate future transmission facilities

**Problem Statement**

Black River 138 kV Area

- Thermal constraints identified in previous Gen Queue and Gen Deliverability Studies.
- Future year analysis shows potential thermal constraints.
  - For the loss of the Avon-Beaver #1 345 kV Line and the Avon-Beaver #2 345 kV Line results in the Black River-Charleston and Charleston-Lorain 138 kV Line loadings to greater than 90% emergency rating.

ATSI Transmission Zone M-3 Process  
 Black River-Astor

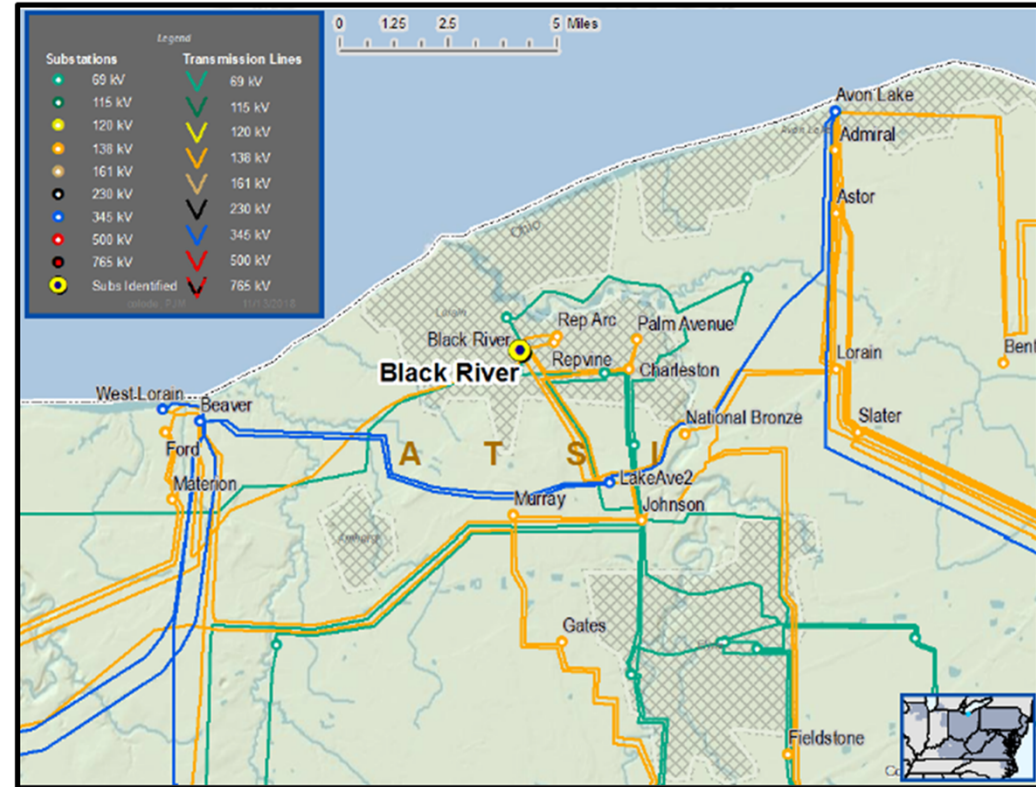



**Need Number:** ATSI-2018-023  
**Process Stage:** Submission of Supplemental Project for Inclusion in the Local Plan - 9/26/2023

**Selected Solution:**

- Build approximately 8 miles of new 138kV line from Black River to Astor substation with a rating of 435 MVA SN / 500 MVA SE.
- Expand / Build a new 138kV four breaker ring bus at Astor to network the following lines and existing transformer at Astor substation:
  - Black River-Astor 138 kV Line (new)
  - Avon-Astor Q11 138 kV Line
  - Astor-Fowles Q11 138 kV Line
  - Astor Transformer #71 138/36 kV (Existing)
- Build approximately 2 miles of new 138 kV line from Republic Vine to Charleston substation with a rating of 278 MVA SN / 339 MVA SE.
- Expand the Charleston 138 kV four breaker ring bus into five (future 6) breaker ring bus to network the following lines at Charleston substation:
  - Republic Vine-Charleston 138 kV Line (new)
  - Black River-Charleston 138 kV Line
  - Charleston-Lorain 138 kV Line
  - Charleston-Palm #1 138 kV Line
  - Charleston-Palm #2 138 kV Line

Project results in a reduction in thermal loading on the Charleston-Lorain 138 kV line from greater than 90% to less than 83 % and on the Black River - Charleston 138 kV line from greater than 90% to less than 75% under problem statement contingency.

## ATSI Transmission Zone M-3 Process Black River-Astor

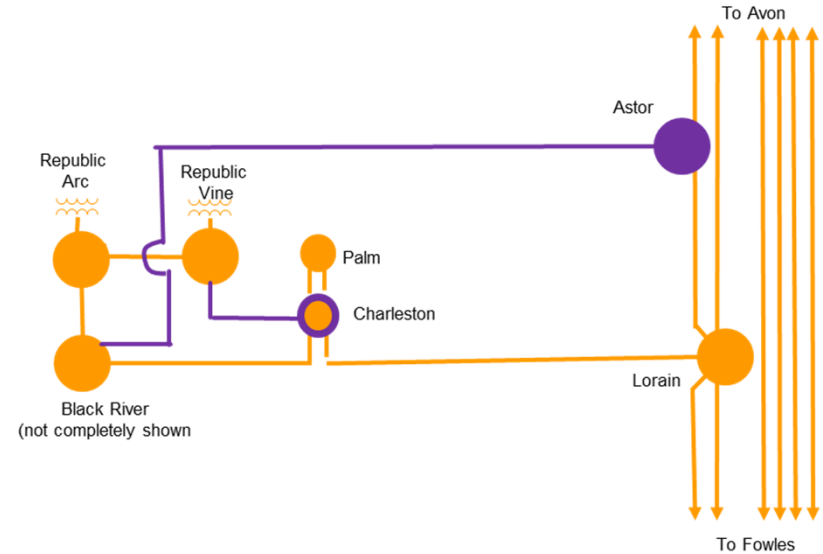

Legend	
500 kV	<span style="color: red;">—</span>
345 kV	<span style="color: blue;">—</span>
138 kV	<span style="color: orange;">—</span>
69 kV	<span style="color: green;">—</span>
34.5 kV	<span style="color: red;">—</span>
23 kV	<span style="color: yellow;">—</span>
New	<span style="color: purple;">—</span>





**Need Number:** ATSI-2018-023  
**Process Stage:** Submission of Supplemental Project for Inclusion in the Local Plan - 9/26/2023

**Transmission Line Ratings:**

- Black River – Astor 138 kV Line
  - Before Proposed Solution: N/A
  - After Proposed Solution: 435 MVA SN / 500 MVA SE
- Republic Vine – Charleston 138 kV Line
  - Before Proposed Solution: N/A
  - After Proposed Solution: 278 MVA SN / 339 MVA SE

**Estimated Project Costs:** \$24.5 M  
**Projected IS Date:** 12/31/2023  
**Supplemental ID:** s1873

## ATSI Transmission Zone M-3 Process Black River-Astor

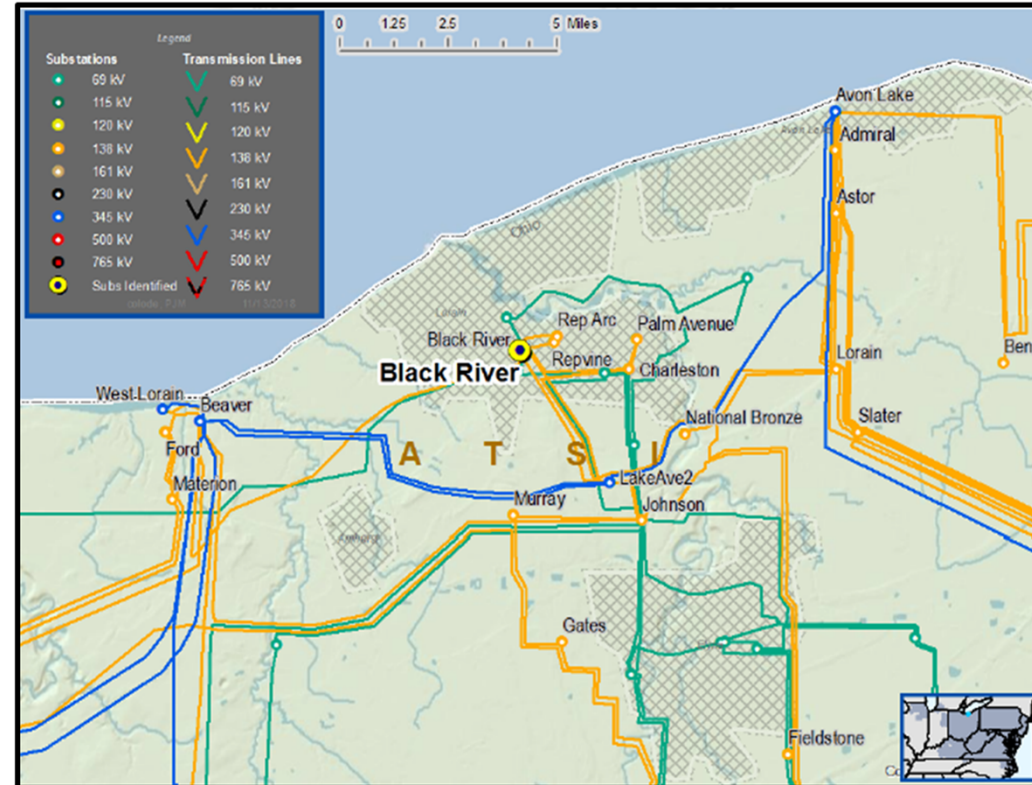



## ATSI Transmission Zone M-3 Process Krendale-Maple 138 kV New Customer

**Need Number:** ATSI-2023-001  
**Process Stage:** Submission of Supplemental Project for Inclusion in the Local Plan – 10/18/2023  
**Previously Presented:** Need Meeting – 3/17/2023  
 Solution Meeting – 5/19/2023

**Project Driver(s):**  
 Customer Service

**Specific Assumption Reference(s)**  
 New customer connection request will be evaluated per FirstEnergy’s “Requirements for Transmission Connected Facilities” document and “Transmission Planning Criteria” document.

**Problem Statement**  
 New Customer Connection - Penn Power Distribution has requested a new 138 kV delivery point near the Krendale-Maple 138 kV line. The anticipated load of the new customer connection is 11 MVA.

Requested in-service date is 06/01/2024.

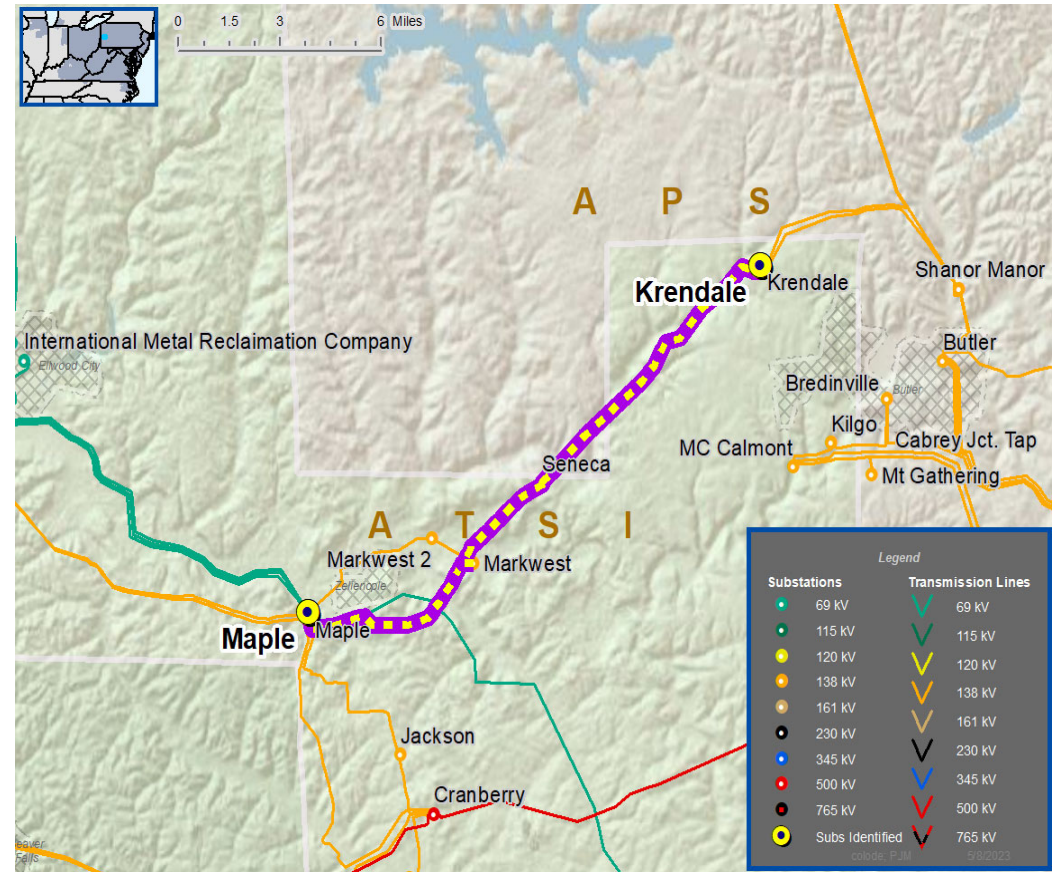



## ATSI Transmission Zone M-3 Process Krendale-Maple 138 kV New Customer-Solution

**Need Number:** ATSI-2023-001  
**Process Stage:** Submission of Supplemental Project for Inclusion in the Local Plan – 10/18/2023

**Selected Solution:**

**138 kV Transmission Line Tap**

- Install three SCADA controlled transmission line switches
- Construct 0.1 miles of 954 ACSR 48/7 transmission line
- Adjust relay settings at Maple substation
- Install tie line interchange revenue metering at Krendale

**Estimated Project Cost:** \$1.7M  
**Projected In-Service:** 06/01/2024  
**Supplemental Project ID:** s2998

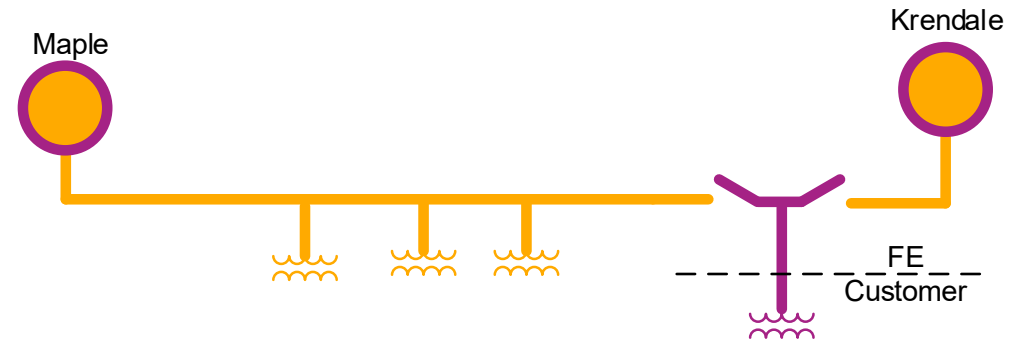

Legend	
500 kV	
345 kV	
138 kV	
69 kV	
34.5 kV	
23 kV	
New	



## ATSI Transmission Zone M-3 Process Chrysler-Maclean 138 kV New Customer

**Need Number:** ATSI-2023-003  
**Process Stage:** Submission of Supplemental Project for Inclusion in the Local Plan – 10/10/2023  
**Previously Presented:** Need Meeting – 4/21/2023  
 Solution Meeting – 6/16/2023

**Project Driver(s):**  
 Customer Service

**Specific Assumption Reference(s)**

New customer connection request will be evaluated per FirstEnergy’s “Requirements for Transmission Connected Facilities” document and “Transmission Planning Criteria” document.

**Problem Statement**

New Customer Connection – Customer has requested a new 138 kV delivery point near the Chrysler-Maclean 138 kV line. The anticipated load of the new customer connection is 30 MVA.

Requested in-service date is 10/01/2024.

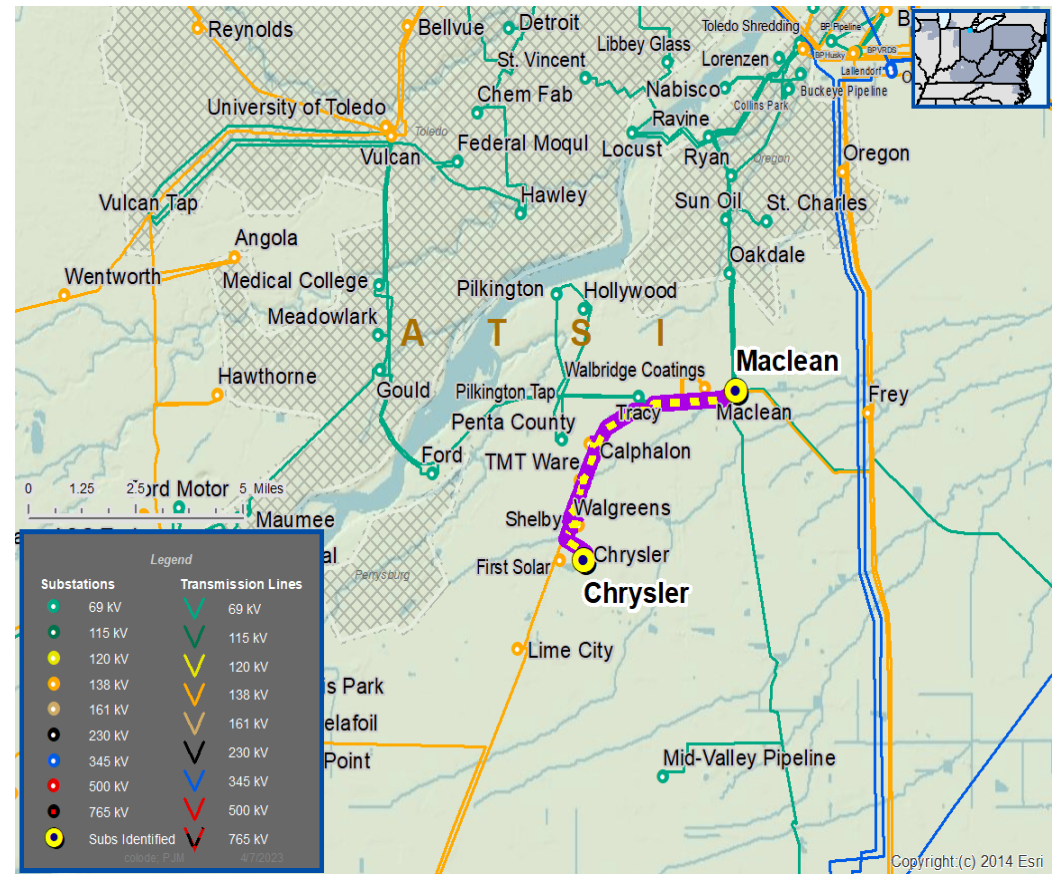





**Need Number:** ATSI-2023-003  
**Process Stage:** Submission of Supplemental Project for Inclusion in the Local Plan – 10/10/2023

**Selected Solution:**

**138 kV Transmission Line Tap**

- Install three SCADA controlled transmission line switches
- Construct approximately 250 ft of transmission line using 954 45/7 ACSR from tap point to the customer substation

**Estimated Project Cost:** \$0.9M  
**Projected In-Service:** 10/1/2024  
**Supplemental Project ID:** s3000

**ATSI Transmission Zone M-3 Process Chrysler-Maclean 138 kV New Customer- Solution**

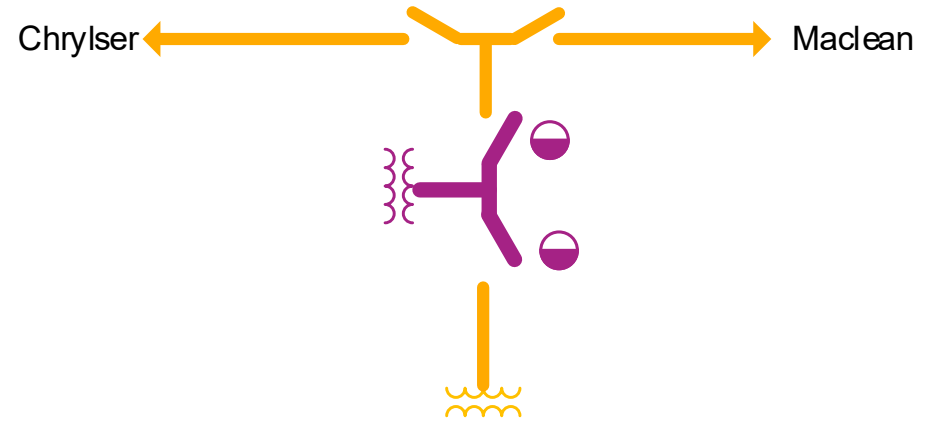

Legend	
500 kV	
345 kV	
138 kV	
69 kV	
34.5 kV	
23 kV	
New	



## ATSI Transmission Zone M-3 Process London - Tangy 138 kV Line Customer Connection

**Need Number:** ATSI-2023-004  
**Process Stage:** Submission of Supplemental Project for Inclusion in the Local Plan – 10/10/2023  
**Previously Presented:** Need Meeting – 3/17/2023  
 Solution Meeting – 5/19/2023

**Project Driver(s):**

*Customer Service*

**Specific Assumption Reference(s)**

Customer connection request will be evaluated per FirstEnergy’s “Requirements for Transmission Connected Facilities” document and “Transmission Planning Criteria” document.

**Problem Statement**

Modified Customer Connection – Ohio Edison Distribution has requested to provide a second 138 kV service to an existing delivery point served from the London-Tangy 138 kV line due to load growth in the area. The anticipated load is approximately 14 MVA.

Requested in-service date is 6/1/2024





## ATSI Transmission Zone M-3 Process London-Tangy 138 kV New Customer-Solution

**Need Number:** ATSI-2023-004  
**Process Stage:** Submission of Supplemental Project for Inclusion in the Local Plan – 10/10/2023

**Selected Solution:**

**138 kV Transmission Line Tap**

- Install one SCADA controlled switch
- Relocate one existing main-line SCADA controlled switch
- Construct approximately 0.1 miles of 795 kcmil 26/7 ASCR transmission line
- Adjust relay settings at London and Tangy substations

**Estimated Project Cost:** \$0.8M  
**Projected In-Service:** 06/01/2024  
**Supplemental Project ID:** s2999

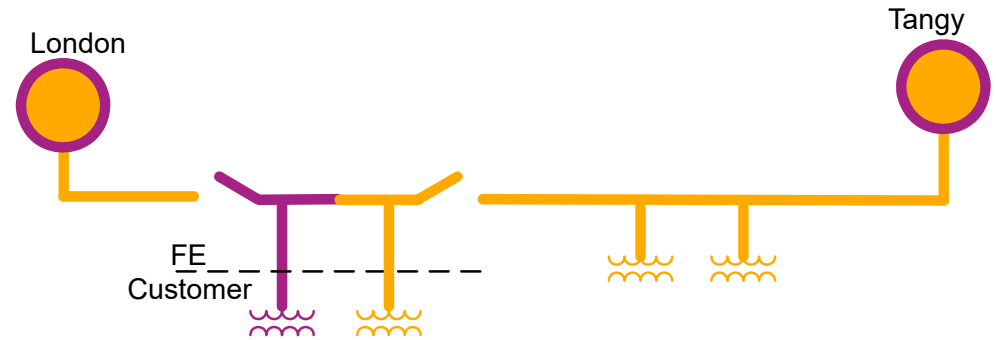

Legend	
500 kV	
345 kV	
138 kV	
69 kV	
34.5 kV	
23 kV	
New	



## Revision History

4/25/2023 – V1 – Added original slides

7/11/2023 – V2 – Added s2923.1, s2923.2, s2924, s2925, s2926 & s1803

9/21/2023 – V3 – Added s1712 (represent), s2936 & s2937

09/26/2023 – V4 – Added s1873

10/18/2023-V5 – Added s2998, s2999 and s3000