



1
2
3
4
5
6
7
8
9

Configuration-Based Combined Cycle Model

March 18, 2011

10
11
12
13
14
15
16
17
18
19
20
21
22
23
24
25
26
27
28
29

Copyright and Proprietary Information

Copyright © 2011 ALSTOM GRID Inc. All Rights Reserved.

NOTE: CONTAINS ALSTOM GRID INC. PROPRIETARY INFORMATION. DO NOT COPY, STORE IN A RETRIEVAL SYSTEM, TRANSMIT OR DISCLOSE TO ANY THIRD PARTY WITHOUT PRIOR WRITTEN PERMISSION FROM ALSTOM GRID INC.

Trademarks

“**ESCA**” and “**HABITAT**” are registered trademarks of ALSTOM GRID Inc. “**eterra**” is a registered trademark and/or service mark of E-Terra, LLC, licensed for use by ALSTOM GRID Inc. in connection with its **e-terra** family of products and services.

Other product and company names in these materials may be trademarks or registered trademarks of other companies, and are the property of their respective owners. They are used only for explanation and to the respective owners’ benefit, without intent to infringe.

30 Contents

31	CONTENTS	3
32	ABOUT THIS DOCUMENT	4
33	CHANGE SUMMARY	4
34	1 INTRODUCTION	5
35	2 FUNCTIONAL REQUIREMENTS	7
36	2.1 CONFIGURATIONS	7
37	2.2 TRANSITION MATRIX	7
38	2.3 CONFIGURATION TRANSITION COSTS	9
39	3 CC GROUP MODELING	11
40	3.1 CONFIGURATION MODEL IN MCE	11
41	3.1.1 <i>Configuration Selection</i>	11
42	3.1.2 <i>Dispatch Range</i>	11
43	3.1.3 <i>Energy Offer</i>	11
44	3.1.4 <i>Minimum and Maximum Up/Down Time</i>	11
45	3.1.5 <i>Transition Matrix and Transition Costs</i>	12
46	3.1.6 <i>Dispatch Ramping Model</i>	12
47	3.1.7 <i>Max Startup Limits</i>	12
48	3.1.8 <i>Max Energy Limits</i>	12
49	3.1.9 <i>AS Models</i>	12
50	3.2 POWER AUGMENTATION MODELING	13
51	3.3 INTERACTION BETWEEN MCE AND NETWORK MODEL IN EMS	13
52	4 PERFORMANCE	15
53	5 APPENDIX: PROPOSED RULES TO CONSTRUCT AGGREGATED UNIT DATA	17

54 **About This Document**

55 This document describes functional requirements and detailed models of
56 configuration based Combined-Cycle group model.

57

58

59

60

61

62

63

64

65

66 **Change Summary**

67

Document Revision	Transmittal #	Date	Comments
0.1		June 15, 2010	Initial Draft [YYX]
0.2		March 20, 2011	Updated based on discussions with MISO.[YYX]

68

69

70 1 Introduction

71 A Combined Cycle (CC) Group consists of one or more Combustion
72 turbines (CT), where each CT has a heat recovery steam generator
73 (HRSG) and the steam produced in the HRSGs is used to drive a steam
74 turbine (ST). Each CT and ST unit has an electrical generator. A typical
75 CCP configuration contains 1 – 4 CTs and one ST only. The configuration
76 used to illustrate model details has 3 CT – 1 ST configuration as presented
77 in Figure 1.1.

78 A CC Group may operate in a number of different configurations (modes)
79 based on the various combinations of the CTs and ST being on-line at any
80 given time. As an illustration, some of the possible configurations for the
81 CC Group used in this document are presented in Figure 1.2. The CC
82 Group operating characteristics differ from one configuration to another
83 and in addition, each transition from one mode of operation to another has
84 its own operational limits and transition costs. Some of transitions are not
85 even allowed (prohibited due to physical or operational constraints).

86 As a result, modeling of CC Group represents a challenge for the MIP
87 based unit commitment and scheduling applications in the Market
88 Management Systems (MMS). The results (unit commitment decisions
89 and dispatch instructions) have to be not only operationally feasible but
90 also should represent an optimal solution in terms of minimizing the
91 overall objective (cost) function.

92 Traditionally, there are several different models used to address flexible
93 configurations and operation of CC Groups in both EMS and MMS (e.g.
94 aggregate CCG representation, physical unit-based models, etc). In
95 addition, they also differ in how detailed is modeling of the CT-ST
96 characteristics and corresponding relationships (e.g. ST MW output has
97 been sometimes modeled as a function of total MW output from CT units;
98 in other cases the steam-to-MW relationship is used for ST unit, and
99 consequently, the steam produced in HRSG has to be modeled, etc).

100 The goal here is to describe in more details only a configuration based CC
101 Group model that has been already used in some MMS (for example,
102 ERCOT) and it may be a good starting point for the MMS applications in
103 other RTO/ISO projects.

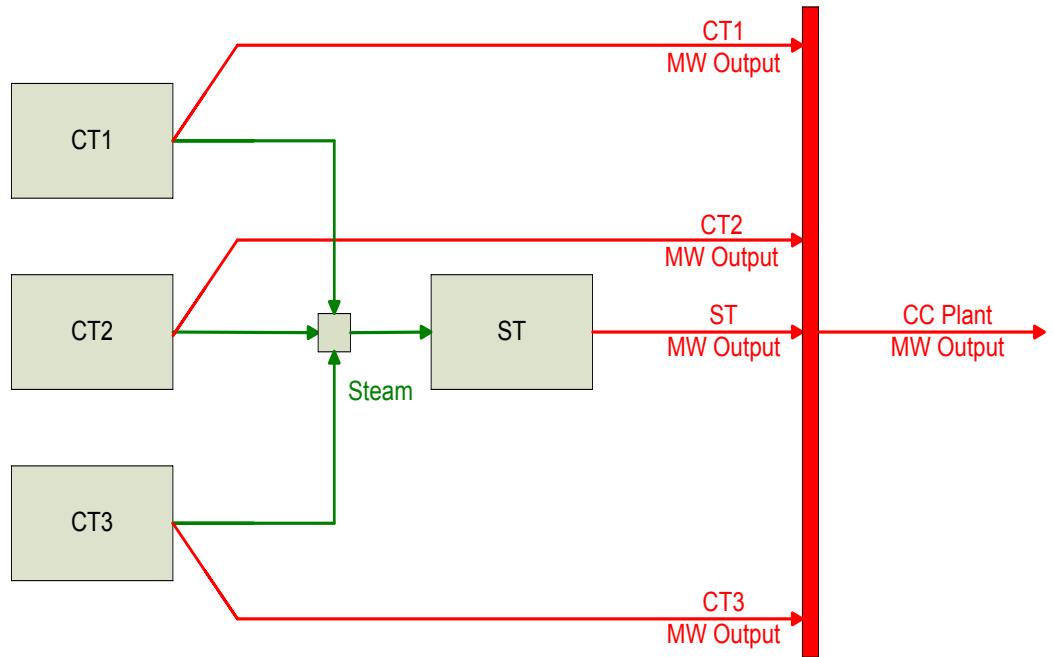

104

105

Figure 1.1 Combined Cycle Group (CCG) – An Example

106 2 Functional Requirements

107 2.1 Configurations

108 A CC group can be operated with various eligible configurations of CTs
109 and STs.

110 For the purpose of this document only a limited number of configurations
111 (4) are presented just as an illustration and an assumption taken in this
112 example is that all the CTs have similar characteristics and therefore the
113 configuration named “1CT” may in reality be any one of the three physical
114 CT units within the CCP operating in a simple/single cycle. Similarly, the
115 “2CT” configuration may be CT1+CT2, CT1+CT3 or CT2+CT3, and so on,
116 as illustrated in the Table 1.1 below. This table presents a mapping
117 between physical units and eligible configurations.

118 **Table 1.1** CC Group Configurations

		ALLOWED CC Group CONFIGURATIONS									
		1 CT			2 CTs			2CTs+ST		3CTs+ST	
PHYSICAL UNITS	CT1	X			X	X		X	X		X
	CT2		X		X		X	X		X	X
	CT3			X		X	X		X	X	X
	ST							X	X	X	X

119

120 It is important to mention that in this approach each CC group
121 configuration is treated as a separate “logical” or pseudo generating unit.
122 Only one of them may be on-line at any given time. Each configuration
123 must have all the operating parameters, limits, energy offer curves,
124 ancillary services (AS) offers, minimum and maximum up/down times,
125 ramp rates, etc like any other “normal” generating unit. Please refer to CC
126 Group Modeling sections for details.

127

128 2.2 Transition Matrix

129 The transition between different CC group configurations is illustrated in
130 Figure 1.2 below and may also be represented in the form of so called
131 transition matrix (Table 1.2). Only allowed transitions are specified and

132
133

provided as an integral part of input data by market participants / CC group owners.

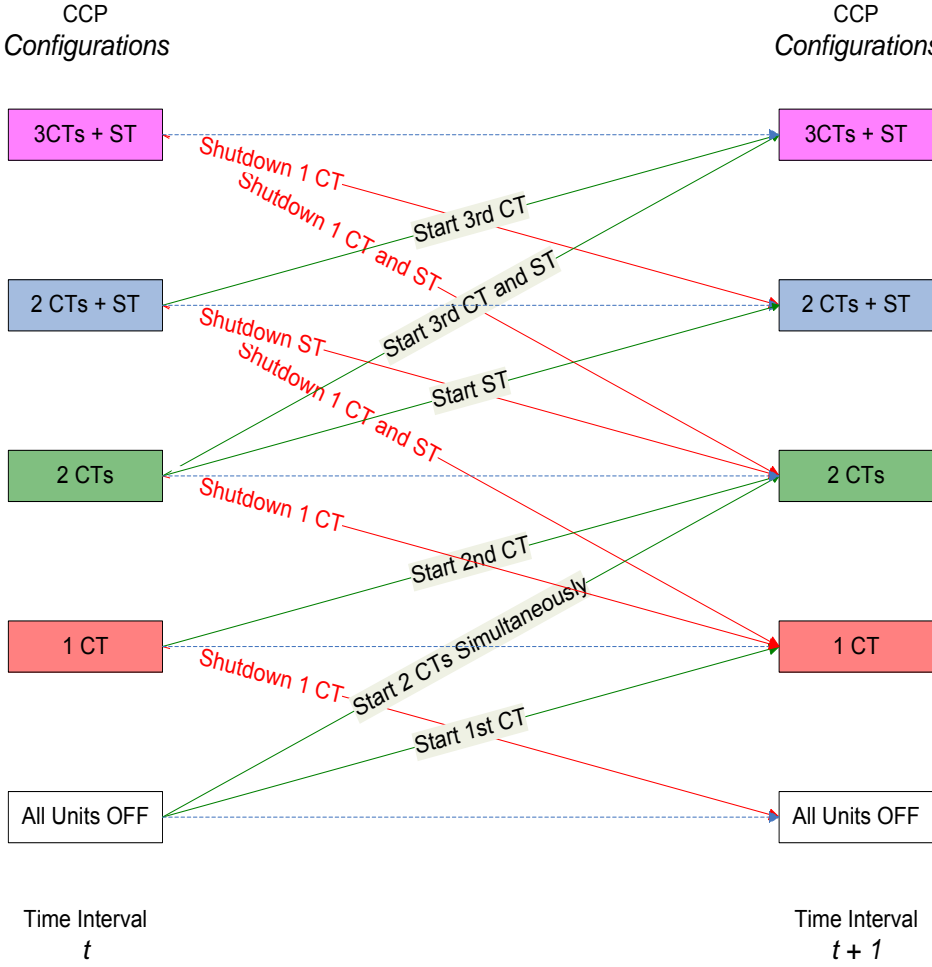

134

135

Figure 1.2 Transitions between CC group Configurations

136

137

138

139

140

141

Transition matrix reflects operational rules for the CC group. Observing table 1.2, one of the rules can be interpreted is: at least 2 CTs must be on-line for the ST unit to be started. The optimal solution must always follow transitions that are feasible from the operational point of view.

Table 1.2 Transition Matrix

TRANSITION		TO CONFIGURATION				
		All OFF	1 CT	2 CTs	2CTs+ST	3CTs+ST
CC	All OFF		↑ UP	↑ UP		

	1 CT	↓ DN		↑ UP		
	2 CTs		↓ DN		↑ UP	↑ UP
	2 CTs + ST		↓ DN	↓ DN		
	3 CTs + ST			↓ DN	↓ DN	

142

143 2.3 Configuration Transition Costs

144 Each CC configuration has its own data for start-up (SU) costs. Normally,
 145 the total SU cost for a given configuration will be calculated as a sum of
 146 the SU costs of the physical units included in the CC configuration. As an
 147 illustration, SU cost for the 2CT+ST configuration will be equivalent to: 2 x
 148 [CT unit SU cost] + [ST unit SU cost], etc.

149 It is assumed that SU costs will be provided as separate parameters for
 150 the cold, intermediate and hot start, along with the corresponding values
 151 for the time off-line that define the warmth state of a unit.

152 Any transition between different CC configurations in fact represents either
 153 unit SU(s) or shut-down (SD) (s). As an example, transition from “All Units
 154 OFF” to 2CTs configuration represents start of 2 CT units simultaneously,
 155 as presented in Figure 1.2.

156 Based on that, the transition costs to be used in the optimization model for
 157 the “up” transitions (i.e. those that are characterized by starting additional
 158 units, as marked in Table 1.2) will be calculated as:

159 ***SU cost of TO-Configuration - SU cost of FROM –Configuration.***

160 Here the cold, intermediate or hot SU costs are to be used based on the
 161 warmth state of the configuration (i.e. time off-line before the transition
 162 takes place).

163 To be noted, warmth state of a configuration is considered based on the
 164 time off-line of a configuration and time thresholds for hot-to-intermediate
 165 and hot-to-cold status change. For example, configuration A with 2CT/1ST
 166 is transferred to configuration B with 1CT/1ST. After 5 hours, configuration
 167 B is changed to configuration A again. When calculating the SU costs, the
 168 cooling time of configuration A should be 5.

169 Costs for shutdown transitions are considered as zero.

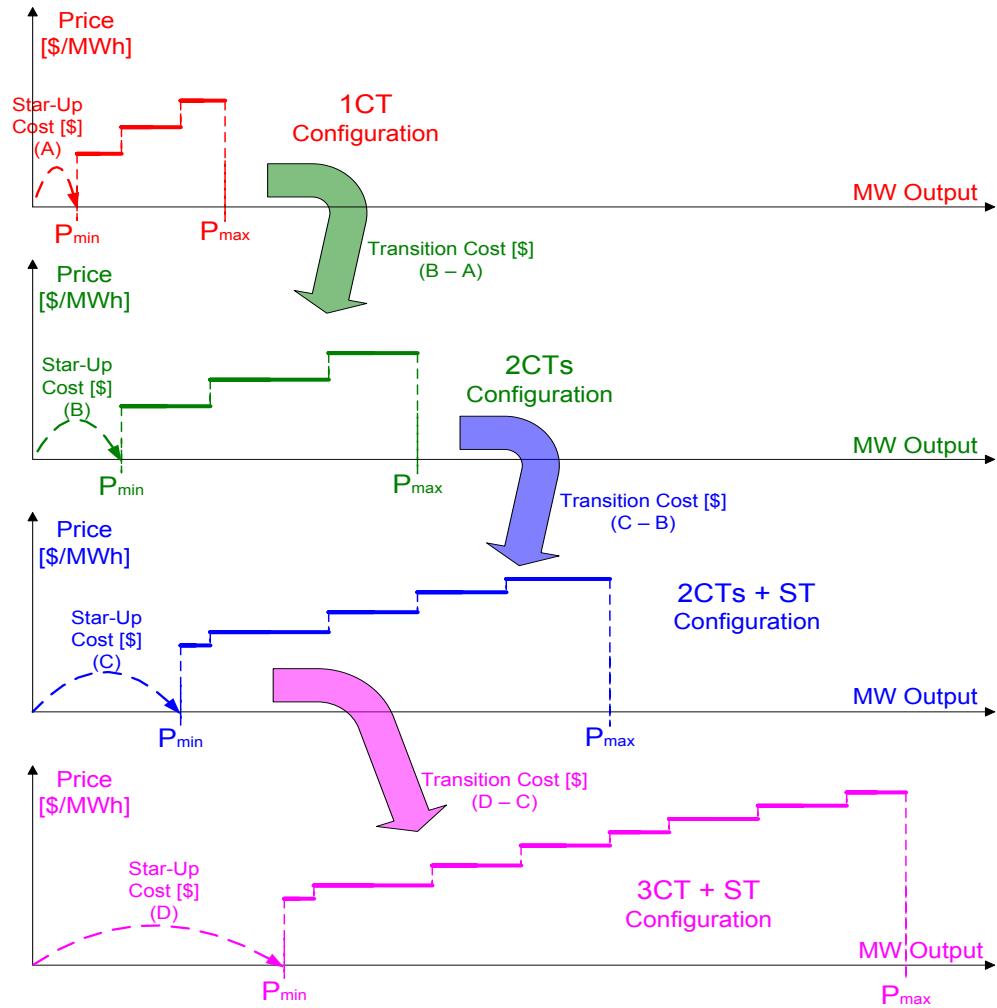

170

171

172

Figure 1.3 Configuration-based Price Curve and Transition Costs

173 **3 CC Group Modeling**

174 Based on the functional requirements described above, the CC Group will
175 be modeled with configuration as basic components.

176 **3.1 Configuration Model in MCE**

177 **3.1.1 Configuration Selection**

178 For a CC group at an interval, only one configuration can be selected for
179 energy and online reserves.

180 **3.1.2 Dispatch Range**

181 For an online CC configuration, it shall be dispatched within the specified
182 dispatch range. During emergency, emergency limits shall be used.

183 **3.1.3 Energy Offer**

184 The following input data will be provided for each pre-defined CC
185 configuration registered with the ISO/RTO for use by the MMS
186 application(s):

- 187 • Energy Offer – Price Curve [\$/MWh]

188 This curve represents a cost of operating a CCP at given MW
189 output (above its minimum economic MW limit). It is defined
190 separately for each CC Configuration as a piece-wise
191 monotonically increasing curve with up to pre-defined max number
192 of segments (e.g. default of 10), as illustrated in figure 1.3.

- 193 • Minimum Load Cost [\$/MWh]

194 This represents a cost of a CC configuration operating at the
195 minimum economic (operating) limit [MW] defined separately for
196 each CC configuration. Minimum and maximum economic limits are
197 considered to be time dependent, i.e. they may be provided on a
198 study interval basis.

199 **3.1.4 Minimum and Maximum Up/Down Time**

200 As mentioned before, each CC configuration may have its own up/down
201 times defined separately. This input data will be used to ensure that once
202 on-line, any configuration should stay on-line for at least the minimum up
203 time. Similarly, the maximum time up may be enforced by including
204 adequate constraints into the mathematical model.

205 To satisfy minimum down time requirement, a CC configuration needs to
206 be offline for at least the down time limit before it's started up again.

207 **3.1.5 Transition Matrix and Transition Costs**

208 CC configuration transfer following given transition matrix.

209 Transition costs are calculated based on the difference between SU costs
210 of "To Configuration" and "From Configuration". Warmth state of "To
211 Configuration" is considered in SU cost model.

212 **3.1.6 Dispatch Ramping Model**

213 For an online configuration, the dispatch between intervals shall not
214 exceed the specific dispatch ramp rate.

215 **3.1.7 Max Startup Limits**

216 For a configuration in a CC group, the total start-up events shall be no
217 higher than the specific max startup limits.

218 **3.1.8 Max Energy Limits**

219 For a configuration in a CC group, the total energy production shall be
220 within the given max energy limit.

221 **3.1.9 AS Models**

222 Energy and AS are dispatched in a co-optimization fashion.

223 **3.1.9.1 AS Dispatch Range**

224 Just like a "normal" generator, with AS product capacity, each
225 configuration may eligible to provide one or multiple AS services.

226 Each AS product shall be cleared within given limits. Total amount of
227 energy and AS products shall be dispatched within a specific range.

228 **3.1.9.2 AS Offer**

229 Similar to an energy offer, the price curve will be modeled for AS Offer for
230 each CC Configuration separately.

231

232 **3.1.9.3 AS Clearing Model**

233 For online reserves, the model is the same as that of normal units.

234 For offline reserve, for example, non-spinning reserve, as offline
235 configurations are more than one, the following specific rules shall be
236 followed for Non-spinning reserve dispatch:

- 237 ▪ No more than one offline configuration can be selected for non-
238 spinning reserve;
- 239 ▪ The offline configuration should be transferable from previous
240 interval's online configuration;
- 241 ▪ The offline configuration should already meet min down time
242 requirement;
- 243 ▪ Max non-spinning reserve amount is: *Capacity of offline*
244 *configuration for non-spinning reserve - Capacity of current*
245 *selected online* configuration at the same interval.

246 **3.2 Power Augmentation Modeling**

247 Power augmentation is the ability of a CC plant to operate at a higher
248 output rating than that of the typical base operating configurations.
249 General power augmentation methods are combustion turbine inlet air
250 cooling (CTIAC), duct firing, and so on. With any power augmentation
251 methods, the efficiency of the CC plant is lower, but it allows the plant
252 have a better load following capability.

253 Power augmentation can be modeled by extending the capacity of
254 corresponding base configurations. For example, for a configuration with
255 ecomax as 100MW and an offer curve with two segments, considering the
256 increased output from power augmentation, the configuration may submit
257 an offer with ecomax as 120MW and an offer curve with additional
258 segment and higher offer price to represent the cost in the augmentation
259 mode.

260 An alternative way is to use additional configurations to model the
261 augmentation mode explicitly. This approach allows to model detailed
262 transition between base configuration and configuration with power
263 augmentation. However, due to additional integer variables and
264 constraints being introduced, it may cause performance degradation.

265 **3.3 Interaction between MCE and Network Model in EMS**

266 For a CC group, EMS network model models individual CT/ST. MCE
267 sees both individual physical units and configurations of CC group.
268 Data interaction between MCE and network model is illustrated in
269 Figure 1.4.

270 Network provides sensitivities of CTs and ST. Based on sensitivities
271 and telemetry output of physical units, sensitivity of a configuration can
272 be estimated. Following the same method, loss penalty factor of CTs
273 and ST can be used to calculate the factor of a configuration.

274 CC group's SE gen value is the total of SE gen MW of CTs/ST.

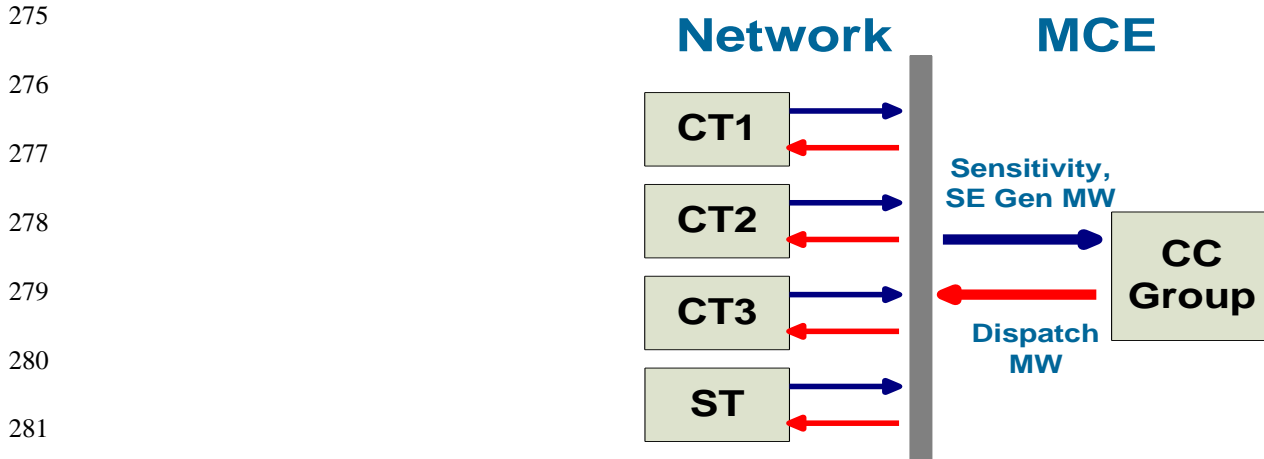

282

283 **Figure 1.4** Data Conversion between EMS and MCE

284 For physical unit power injection data, configuration level dispatch MW
285 will be disaggregated based on capacity of individual physical units
286 and steam factor of the ST.

287 Initial configuration can be determined based on the online status of
288 CT/ST. Minimum value of initial on (off) times of all physical units is
289 considered as the initial on (off) time for the configuration.

290 4 Performance

291 For CC group modeling, potential performance issues may be caused by additional
292 integer variables and constraints, where the amount of integer variables and constraints
293 depends on.

- 294 • number of CC groups,
- 295 • number of CTs in CC group,
- 296 ▪ transition matrix density.

297 Compared with sparse transition matrix, obviously more solutions needed to be
298 searched over for an optimal one for CC groups with dense transition matrix.

299 To improve performance, all methods should focus on:

- 300 • Reducing candidate configurations
- 301 • Pruning transition matrix.

302 A two-round-solve based method is proposed to improve performance on CC group
303 modeling:

- 304 1. 1st round solve with Aggregation CC model to calculate total MW dispatch of the
305 whole CC group. In the aggregation model, the whole CC group is treated as one
306 generator. Please refer to Appendix for proposed rules to construct data for the
307 aggregated unit based on characteristics of physical units.
- 308 2. Based on total MW dispatch, reduce configurations and prune transition matrix.
309 For example, as shown in figure 1.5, the configuration set has been reduced to
310 only include configurations with bold frames, and transition paths also have been
311 pruned to a great degree, as indicated in thick lines.

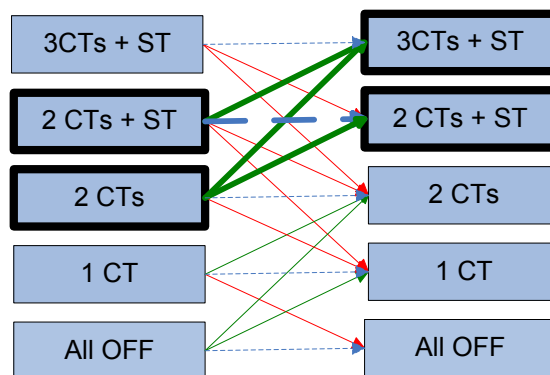

312 **Figure 1.5** Reducing Configurations and Pruning Transition Matrix

313

314

315

- 3.** 2nd round solve with configuration based CC model and based on the reduced configurations and transition matrix.

316

317 **5 Appendix: Proposed Rules to Construct**
318 **Aggregated Unit Data**

319 The following rules are proposed to construct data for the aggregated unit
320 based on input data of the physical units within the CC group:

- 321 • SU cost takes the average of SU cost of each CTs.
- 322 • Ecomin is the minimum value of ecomin of all CTs;
- 323 • Ecomax is the sum of ecomax of the CC group;
- 324 • Energy offer price curve is Ecomax weighted average of the CC
325 group;
- 326 • AS capacity for regulation reserve is within the range of [min
327 regmin, sum regmax] of all units in the CC group;
- 328 • AS capacity for other reserve types may be sum of ecomax or
329 emergency Max.
- 330 • Minup/down time may use the minimum value of min up/down time
331 of units in the CC group.
- 332 • ED ramp rate may use average of ED ramp rates of all units in the
333 group.

334 These rules are subject to change based on MISO's preference and case
335 analysis results.