

# Submission of Supplemental Projects for Inclusion in the Local Plan

# AEP Transmission Zone M-3 Process Bockoven Switch

**Need Number:** AEP-2018-IM005

**Process Stage:** Submission of Supplemental Project for inclusion in the Local Plan 4/12/2019

**Previously Presented:**

Solution Meeting 11/29/2018

Needs Meeting 10/26/2018

**Supplemental Project Driver:**

Customer Request

**Specific Assumption References:**

AEP Guidelines for Transmission Owner Identified Needs (AEP Assumptions Slide 7)

**Problem Statement:**

A customer has requested connection of a 2.3MVA load off of the Berne – Portland 69kV line.

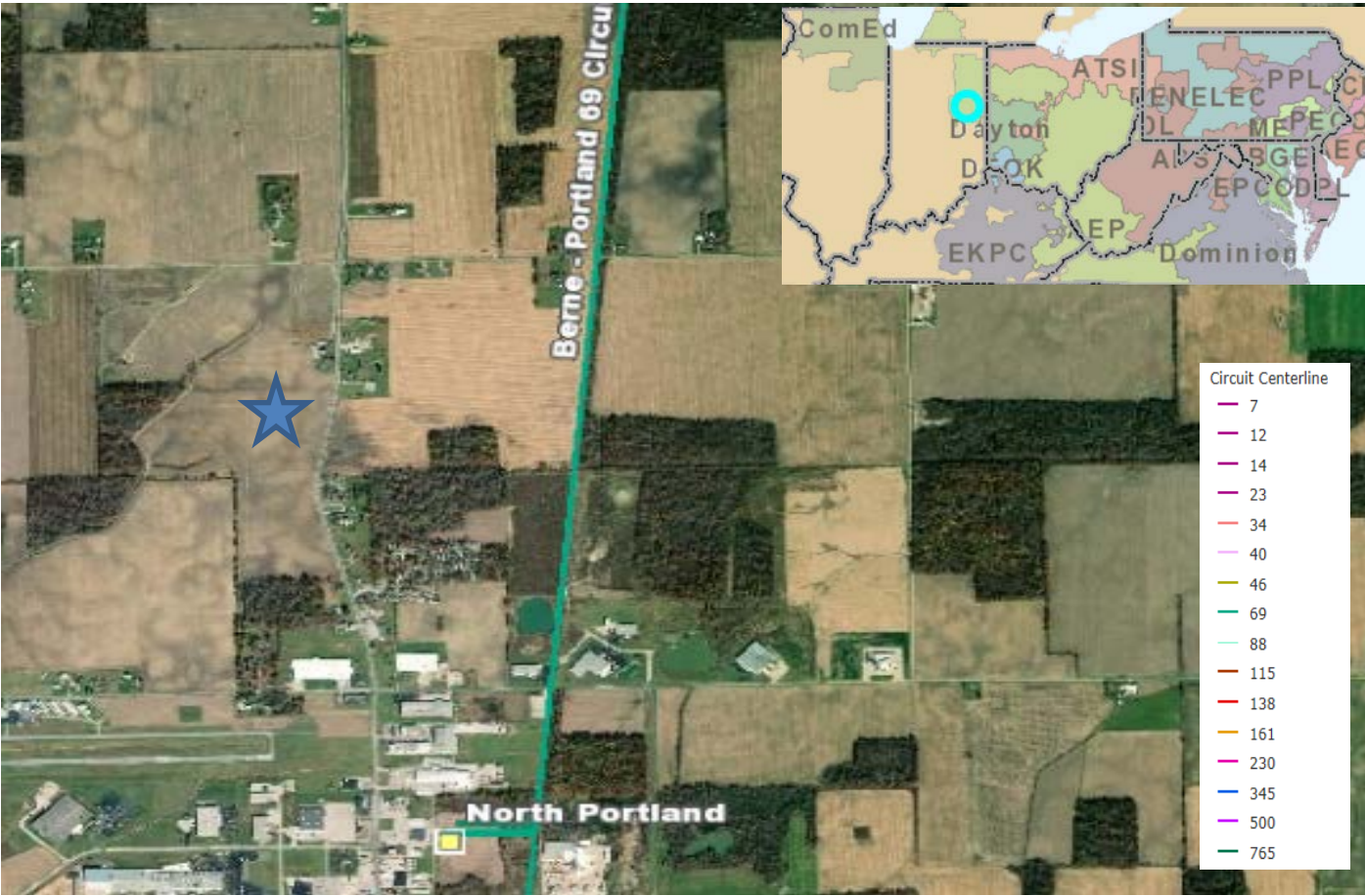

# AEP Transmission Zone M-3 Process Bockoven Switch

**Need Number:** AEP-2018-IM005

**Process Stage:** Submission of Supplemental Project for inclusion in the Local Plan 4/12/2019

**Selected Solution:**

Install a 3-way PoP switch called Bockoven Switch with line MOABs with automatic sectionalizing between Trinity and North Portland 69KV switches. Install 0.5 mile extension to customer with 556 ACSR conductor.

**Estimated Cost:** \$2.6M

**Projected In-Service:** 1/15/2019

**Supplemental Project ID:** S1791

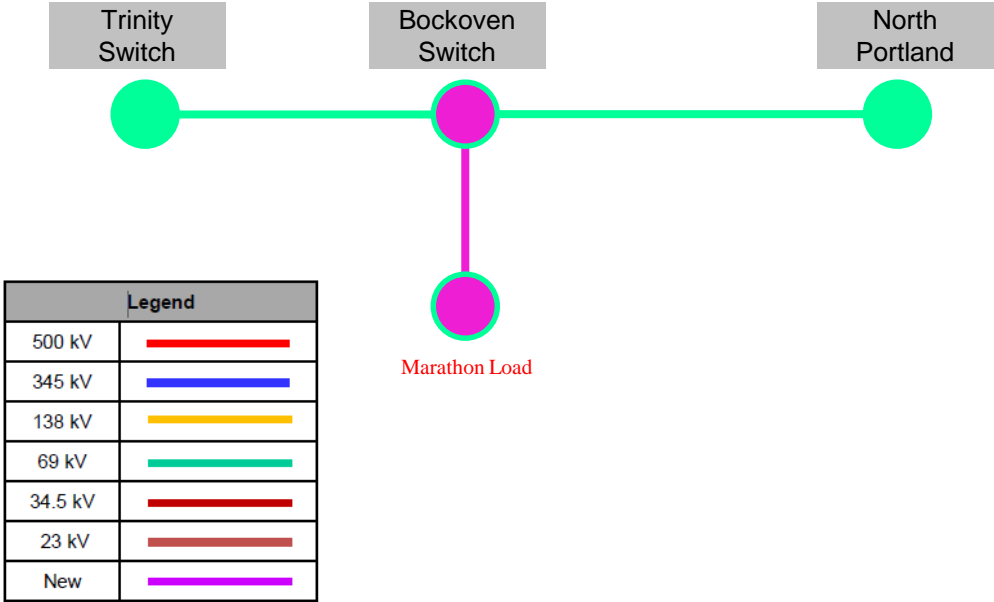

# AEP Transmission Zone M-3 Process Isabella Station

**Need Number:** AEP-2018-OH010

**Process Stage:** Submission of Supplemental Project for inclusion in the Local Plan 4/12/2019

**Previously Presented:**

Solution Meeting 11/29/2018

Needs Presented: 10/26/2018

**Supplemental Project Driver:** Customer Service

**Specific Assumption References:**

AEP Guidelines for Transmission Owner Identified Needs (AEP Assumptions Slide 7)

**Problem Statement:**

Customer Service #1: AEP Ohio has requested a connection to the Crooksville – North Newark 138 kV circuit. Isabella station will replace their Redfield station. Redfield Distribution equipment is in need of rehab and it is distant from Distribution load centers. The starting load at Isabella will be 3.5 MVA and the ultimate load will be 10 MVA. Load will be transferred load from Redfield and South Fultonham. The existing Redfield 69kV Station has experienced 1,730,000 CMI over a three year period.

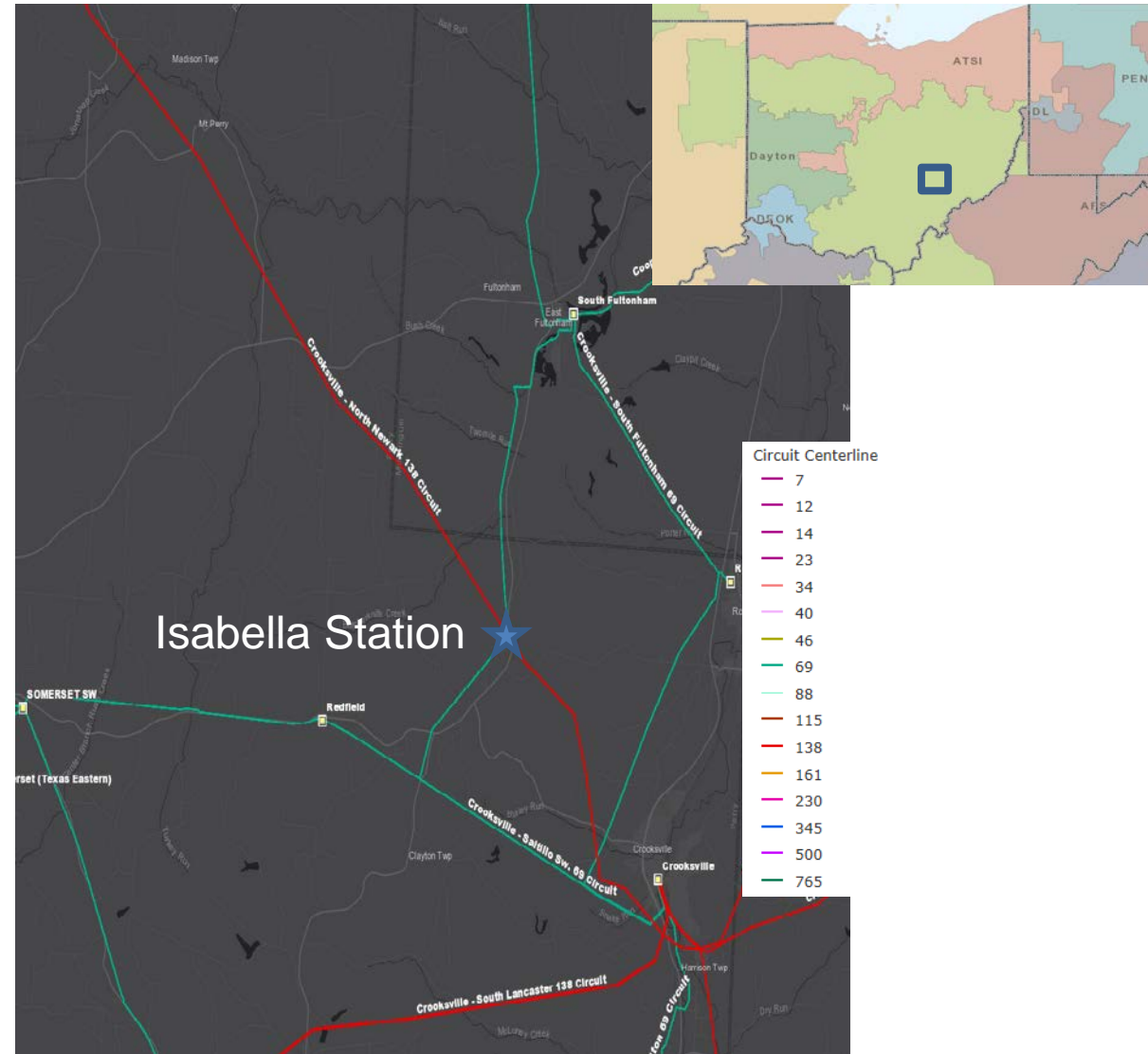

# AEP Transmission Zone M-3 Process Isabella Station

**Need Number:** AEP-2018-OH010

**Process Stage:** Submission of Supplemental Project for inclusion in the Local Plan 4/12/2019

**Selected Solution:**  
Build a new 138 kV in and out Isabella station with Moab switches to connect to the Crooksville – North Newark 138 kV circuit.  
Build a new 0.17 mile 138 kV extension to Isabella Station.

**Estimated Cost:** \$2.07M

**Projected IS Date:** 6/15/2019

**Supplemental Project ID:** S1792

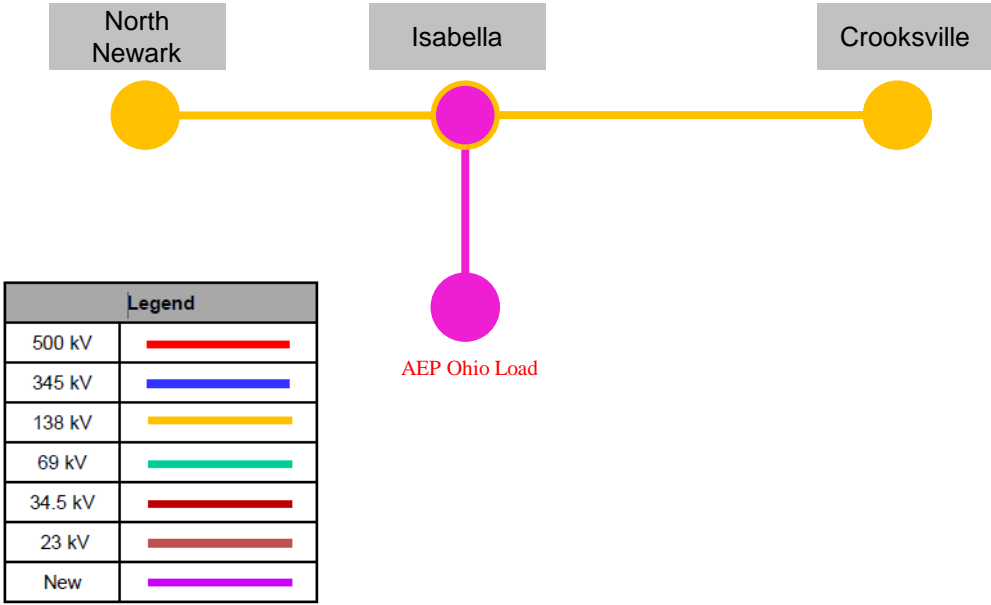

## AEP Transmission Zone M-3 Process Fries-Independence

**Need Number:** AEP-2018-AP001

**Process Stage:** Submission of Supplemental Project for inclusion in the Local Plan 8/29/19

**Previously Presented:**

Needs Meeting 10/26/2018

Solutions Meeting 1/11/2019

**Project Driver:**

Equipment Condition/Performance/Risk

**Specific Assumption Reference:**

AEP Guidelines for Transmission Owner Identified Needs (AEP Assumptions Slide 8)

**Problem Statement:**

The Fries – Independence 69kV line is an 11 mile long radial line and maintenance cannot be performed due to a lack of outages available on the line. Approximately 20 MVA is served out of Independence during winter peak conditions and is dropped for outages on this circuit. From 2013-2018, the Fries – Independence 69 kV circuit has experienced 5 permanent outages and 4 momentary outages, resulting in approximately 5.7M customer minutes interrupted. Fries – Independence 69 kV line has 23 open conditions associated with the structures that make up the line. Conditions include woodpecker damage and rot top. Majority of the circuit utilizes 1950s wood structures

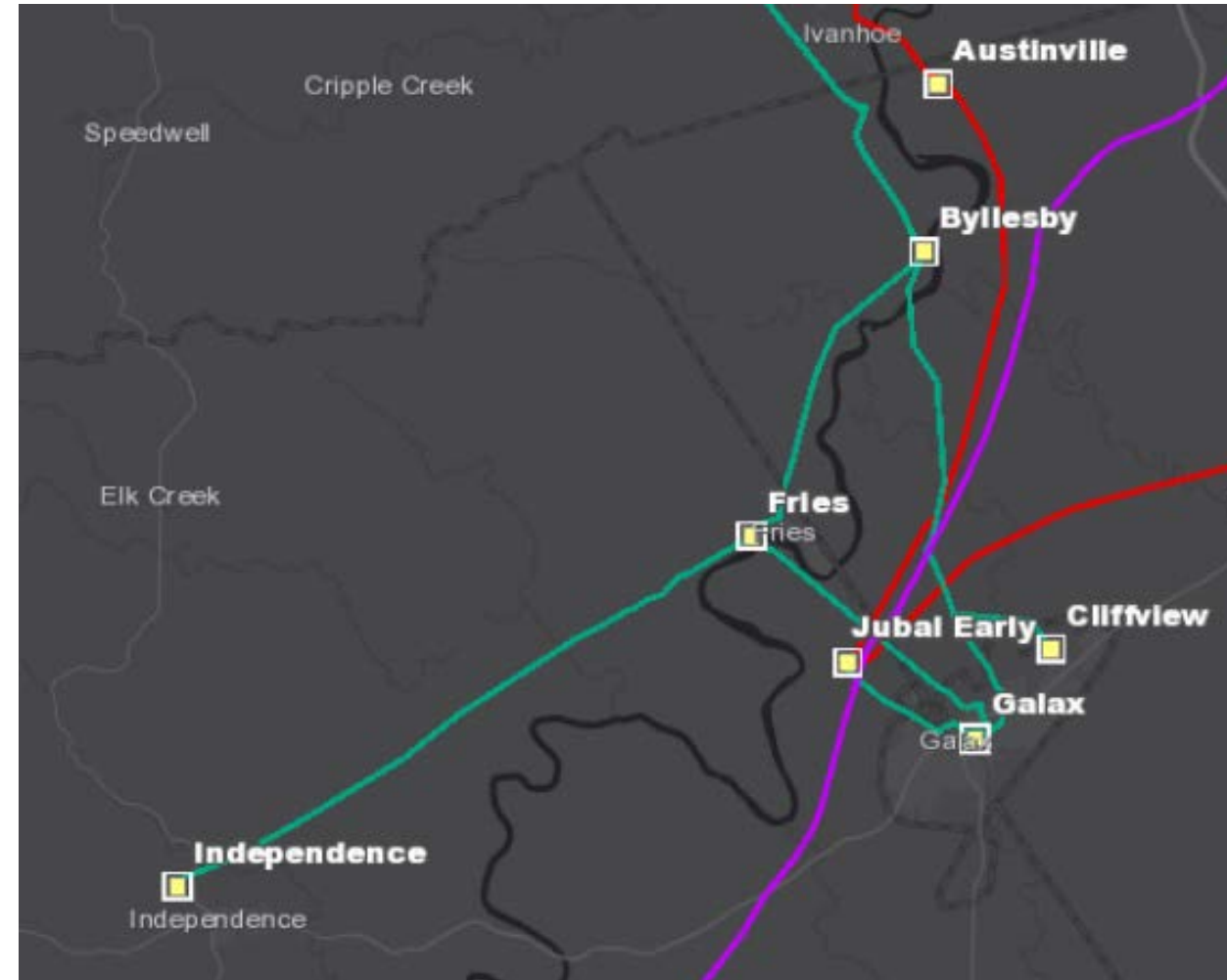

# AEP Transmission Zone M-3 Process Fries-Independence

**Need Number:** AEP-2018-AP001

**Process Stage:** Submission of Supplemental Project for inclusion in the Local Plan 8/29/2019

**Selected Solution:**

Construct a new 69 kV line (approximately 15 miles) from Jubal Early Station to Independence Station. Install a 69 kV circuit breaker at Jubal Early Station and two 69 kV circuit breakers at Independence Station.

**Ancillary Benefits:** Providing looped service to the customers served from Independence Station will allow for outages for maintenance or construction.

**Estimated Cost:** \$32.5M





**Projected In-Service:** 6/1/2022

**Supplemental Project ID:** S1851

**Project Status:** Scoping

**Model:** N/A



Legend	
345 kV	
138 kV	
69 kV	
46 kV	
New	

# AEP Transmission Zone M-3 Process Fieldale

**Need Number:** AEP-2018-AP007

**Process Stage:** Submission of Supplemental Project for inclusion in the Local Plan 8/29/19

**Previously Presented:**

Needs Meeting 10/26/18

Solution Meeting 2/20/2019

**Project Driver:**

Equipment Condition/Performance/Risk

**Specific Assumption Reference:**

AEP Guidelines for Transmission Owner Identified Needs (AEP Assumptions Slide 8)

**Problem Statement:**

Fieldale Station: Circuit breakers "J" (recently failed), "T" (39 operations), and "F" (15 operations) are FK type oil breakers. The drivers for replacement are bushing damage, no repair part availability and potential of PCB (polychlorinated biphenyl) presence. PCB was used as coolant and lubricant in electrical equipment because of their insulation capabilities. Their manufacturing was stopped in 1977 because of evidence of environment issues and harmful health effects. However, equipment installed prior to 1977 is at risk of having PCB contents.

Breakers "BC" (30 fault operations) and "AC" (31 fault operations) are air blast breakers. AEP is replacing air blast breakers across the system because of safety concerns. These types of breakers tend to fail violently, frequently dispersing porcelain shards from their bushings during failures which is a safety issue for station personnel and public.

Breakers "G" (36 operations), "C" (47 operations), and "D" (27 operations) are also oil breakers but of the type ITE (CB G and CF-48 (CB C & D). Oil breaker maintenance has become more difficult due to the oil handling required. CF-48 also are notorious for mechanical damage related to the breaker's open and close contacts.

Circuit switchers "DD" and "EE" are Mark V type. Mark V's are an obsolete type that do not coordinate with modern relaying packages. Other drivers for replacement are age and no repair part availability. Transformer 3 (recently failed) is showing a breakdown in winding insulation (dielectric strength). It also shows C2H2 levels above IEEE thresholds. Age and short circuit strength breakdown (due to the amount of through faults suffered) is the main driver for replacement.

Transmission lines out of Fieldale have pilot wire protection. Copper pilot wire is an obsolete technology, and since the telephone companies almost never use it anymore, it is increasingly difficult to find suitable pilot wire cable and hardware.

**AEP Local Plan -2019**





*Continued from previous slide*

## **Fieldale Synchronous Condenser**

- The Fieldale Synchronous Condenser was originally installed in 1974 and is one of only two facilities that provide dynamic voltage regulation and power factor compensation to the AEP 138kV system in Virginia.
- The unit was initially capable of +/-250 MVAR but has since been de-rated to +158/-35 MVAR primarily due to the original Amplidyne excitation control replacement in 1997 with a Basler control. There are no replacement parts or factory support for this Basler unit. If the Basler unit was to fail, the machine would be off-line until a replacement excitation system could be procured and installed.
- The DFR is being replaced due to the maintenance and reliability issues experienced with its model. Protection systems for the condenser utilize electromechanical relaying that is obsolete with no available spares.
- There is no longer vendor support for the existing controls system as well as limited spare parts availability. APCo personnel have devised replacements and workarounds that allow operation of the synchronous condenser. Particular issues include inconsistent mechanical temperature switches, intermittent electrical relays in the control circuitry, and intermittent operation of auxiliary circuit breakers. Other problems occur at the interface between the original mechanical and analog controls and more modern digital controls that have been added to the system, making startup syncing difficult.
- The existing device has multiple problems with the cooling such as water leakages. Corrosion of the steel parts of the cooling system is becoming more of a concern from a machine reliability standpoint. There is no longer vendor support for the cooling system which has made spare parts difficult to procure.
- Environmental concerns include the use of mercury in some switches (26 units with approx. 2 ounces of mercury per unit), the use of asbestos for insulation, and the possibility of bacterial contamination in the cooling system. Due to the open loop cooling system being at a higher risk to develop bacteria, respirators are required when cleaning the cooling pit during maintenance.



Cooling tower  
interior pan

*Continued from previous slide*

DuPont Station: 69 kV circuit breakers 'A' (8 operations), 'B' (38 operations) and 'C' (14 operations) are GE 'FK' oil-filled breakers which have little to no replacement parts and were installed in 1960, 1959 and 1968 respectively. In general, oil breakers have become increasingly difficult to maintain due to the associated oil handling. Oil spills are frequent with failures and routine maintenance, which is an environmental hazard.

Blaine Station: Circuit Switcher 'AA' is a Mark V switcher, which is no longer supported by the manufacturer and parts are not available. Parts are increasingly difficult to locate during maintenance. These are older designed circuit switchers with old controls that no longer coordinate well with modern relaying.

Morris Novelty: 34 kV circuit breaker 'E' and 'F' are GE 'FK' oil-filled breakers which have little to no replacement parts. In general, oil breakers have become increasingly difficult to maintain due to the oil handling associated with them. Oil spills are frequent with failures and routine maintenance which is also an environmental hazard.

Rich Acres: Because of pilot wire retirement on this line, a new circuit switcher on transformer #1 will be needed to coordinate with new line relays on the Fieldale – Ridgeway 69 kV line.

### **Operational Flexibility and Efficiency:**

Based on the measures that are required to be performed when the existing 250 MVAR synchronous condenser is not in service due to maintenance, Transmission Operations Engineering recommends the presence of an active reactive power device at Fieldale Station. The installation of additional static reactive power devices such as shunt capacitor banks would resolve the low voltages that could occur in the isolated scenarios of facility outages, but would likely aggravate the customer issues that exist with such discrete devices. The recommendation would be to install a similarly sized synchronous condenser that would tend to diminish the impacts of transient harmonics and assist in reducing the possible concern of dynamic instability due to the present system configuration where there is no local AEP generation.

**Need Number:** AEP-2018-AP007

**Process Stage:** Submission of Supplemental Project for inclusion in the Local Plan 8/29/19

**Selected Solution:**

**Fieldale Station (\$51.5 M) S1852.1**

Replace Synchronous Condenser with two units (-50/+100 MVAR). Retire 138 kV Circuit Breakers AC and AB and install new 3000A, 40kA CBs.

Replace 138 kV Circuit Switcher EE & DD with new 3000 A, 40 kA

Replace 69 kV CB-F with new 72.5 kV, 3000 A, 40 kA circuit breaker

Retire 34.5 kV equipment including CB T, 7.2 MVAR Capacitor Bank and Circuit Switcher AA

Move 69 kV Fieldcrest Mills load to 12 kV service and retire radial 69 kV line to Fieldcrest Mills and Fieldcrest Mills Station

**DuPont Station (\$1.5 M) S1852.2**

Retire 3 69 kV breakers (A, B and C) and replace with two line MOABs

**Blaine Station (\$1.7 M) S1852.3**

Replace 138 kV S&C Mark V circuit switcher AA

**Morris Novelty Station (\$1.7 M) S1852.4**

Reconfigure existing 69kV capacitor bank from a 15.6 MVAR to 10.8 MVAR

Replace 34.5 kV FK oil CB "F" and "E"

**Rich Acres (\$0.6 M) S1852.5**

Add high side circuit switcher to transformer #1

**Estimated Cost:** \$60M

**Projected In-Service:** 12/1/2022

**Supplemental Project ID:** S1852.1 – S1852.5

**Project Status:** Scoping

**Model:** N/A

**Bubble Diagram Not Applicable  
Station Upgrades Only**

**Need Number:** AEP-2018-AP008

**Process Stage:** Submission of Supplemental Project for inclusion in the Local Plan 8/29/2019

**Previously Presented:**

Needs Meeting 10/26/2018

Solutions Meeting 1/11/2019

**Project Driver:**

Customer Service

**Specific Assumption Reference:**

AEP Connection Requirements for the AEP Transmission System (AEP Assumptions Slide 7)

**Problem Statement:**

Virginia Tech Electric Service (VTES) requested a new 69 kV delivery point from AEP's Lane substation located in Blacksburg, VA to serve 5 MW of new load.

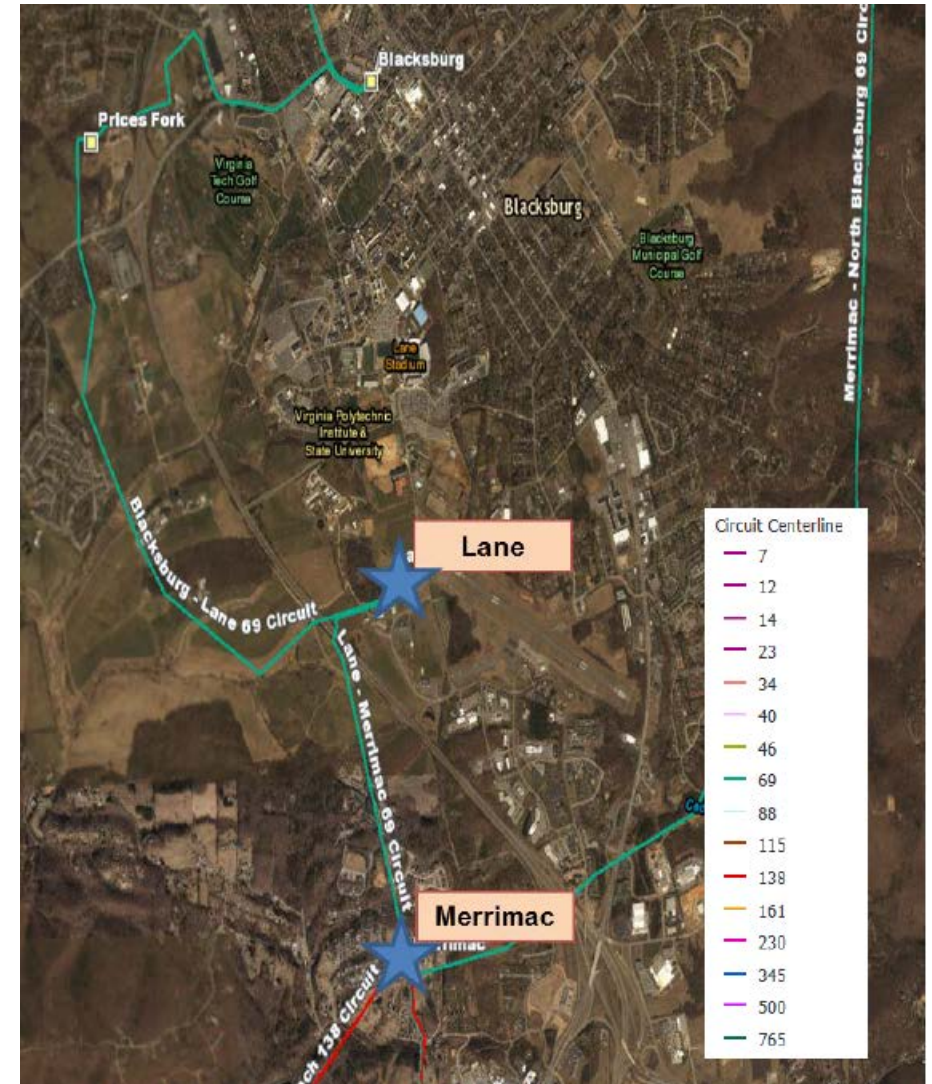

**Need Number:** AEP-2018-AP008

**Process Stage:** Submission of Supplemental Project for inclusion in the Local Plan 8/29/2019

**Selected Solution:**

- Expand Lane Station to establish a new VTES 69 kV delivery point
- Install one 69 kV circuit breaker and associated equipment
- Motorize an existing 69 kV line switch
- Add 12 kV metering to two new customer owned 69/12 kV transformers
- Relocate Lane-Merrimac 69 kV line to accommodate the station expansion/new line termination location

**Estimated Cost:** \$0.2M

**Projected In-Service:** 8/1/2019

**Supplemental Project ID:** S1853

**Project Status:** Engineering

**Model:** 2024 RTEP

**Bubble Diagram Not Applicable  
Station Upgrades Only**

# AEP Transmission Zone M-3 Process Southern Muncie

**Need Number:** AEP-2018-IM007

**Process Stage:** Submission of Supplemental Project for inclusion in the Local Plan 8/29/2019

**Previously Presented:**

Needs Meeting 10/26/2019

Solution Meeting 1/11/2019

**Project Driver:**

Equipment Condition/Performance/Risk

**Specific Assumption Reference:**

AEP Guidelines for Transmission Owner Identified Needs (AEP Assumptions Slide 8)

**Problem Statement:**

Medford Station

- Transformer 1 – 1959 Vintage
  - Extremely high values of combustible gasses
  - Overheating faults have occurred within the unit.
  - Interfacial tension and the power factor values are at concerning levels proving the oil quality degradation
- Breakers "A" "B" and "C"
  - 1943-53 vintage FK oil breakers without containment
  - Fault Operations: CB A(53) CB B(27) CB C(21) – Recommended(10)

23rd Street Station

- Breakers "B", "C", "D", "E", "G", "J" and "K"
  - 1971 vintage FK oil breakers without containment
  - Fault Operations: CB B(30) CB C(44) CB D(16) CB E(0) CB G(25) CB J(18) CB K(28) – Recommended(10)

Arnold Hogan

- Distribution XF 2 – 1970 Vintage
  - Experienced a failure in 1999

Blaine Street Station

- Breaker "E"
  - 1970 vintage oil filled FK-breakers without oil containment
  - Fault Operations: CB E(29) – Recommended(10)

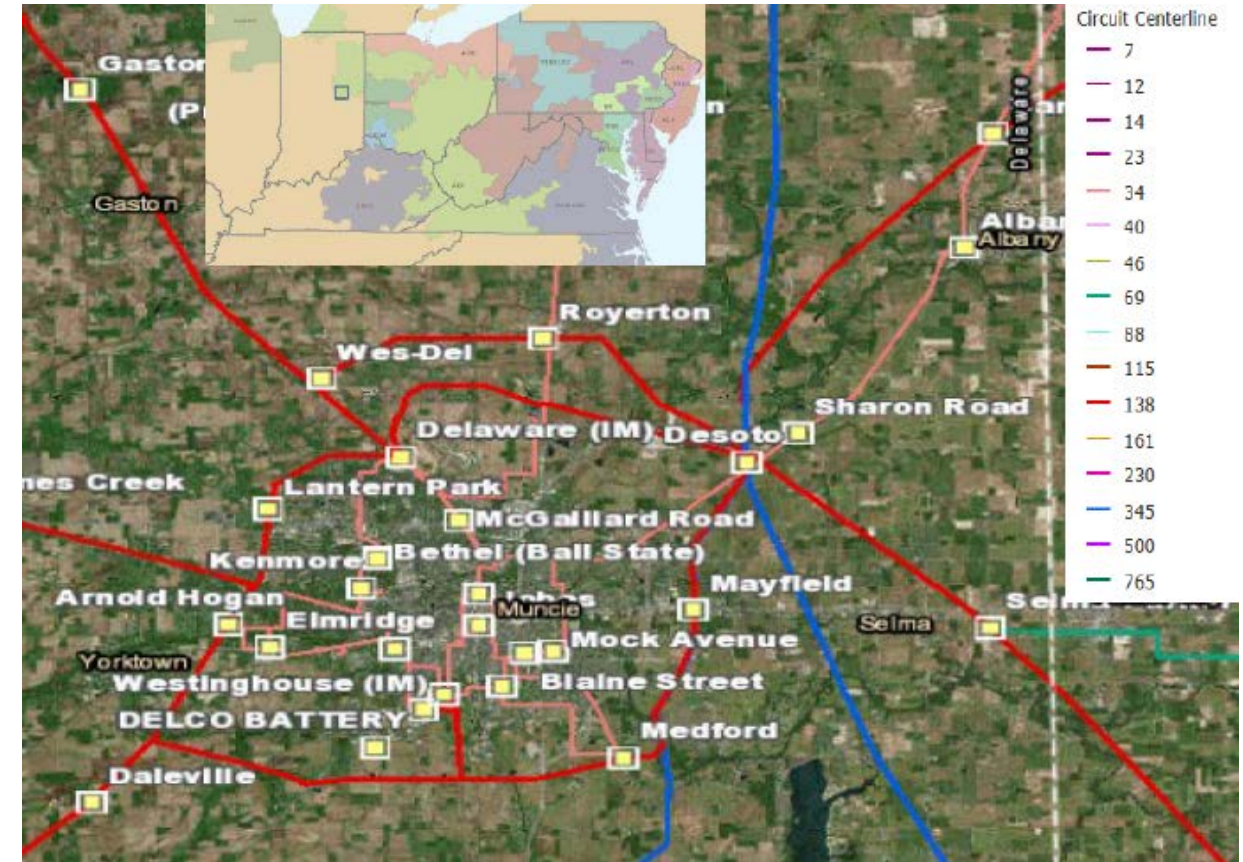

# AEP Transmission Zone M-3 Process Southern Muncie

**Need Number:** AEP-2018-IM007

**Process Stage:** Submission of Supplemental Project for inclusion in the Local Plan 8/29/2019

**Previously Presented:**

Needs Meeting 10/26/2019

Solution Meeting 1/11/2019

**Project Driver:**

Equipment Condition/Performance/Risk

**Specific Assumption Reference:**

AEP Guidelines for Transmission Owner Identified Needs (AEP Assumptions Slide 8)

**Problem Statement:**

Arnold Hogan – 23rd Street

- 1963 wood crossarm construction
- 3/0 copper and 4/0 ACSR
- Subject to 20 open A conditions
- Subject to 26 open B conditions
- In the past 10 years, 47 structures have had active maintenance performed. This is expected to increase as line ages.

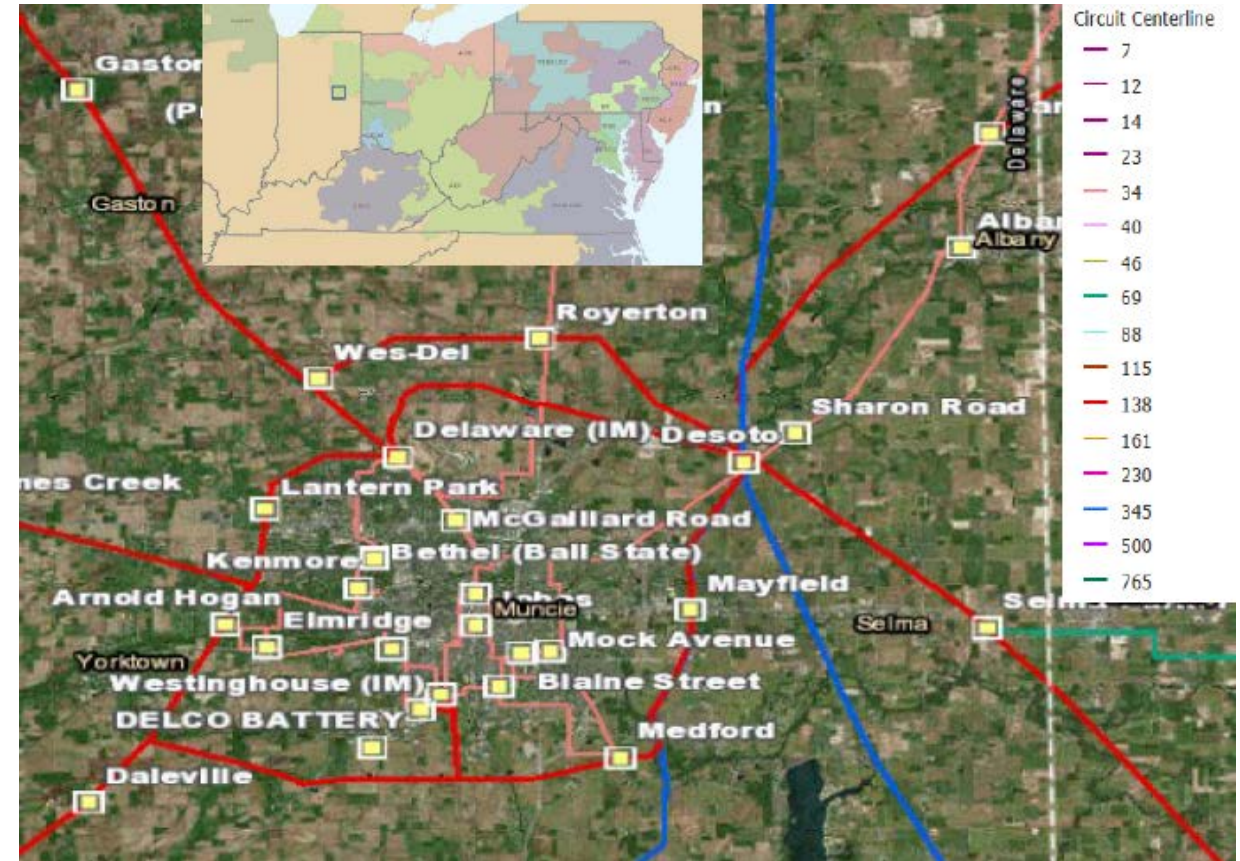

# AEP Transmission Zone M-3 Process Southern Muncie

**Need Number:** AEP-2018-IM007

**Process Stage:** Submission of Supplemental Project for inclusion in the Local Plan 8/29/2019

**Previously Presented:**

Needs Meeting 10/26/2019

Solution Meeting 1/11/2019

**Project Driver:**

Operational Flexibility and Efficiency

**Specific Assumption Reference:**

AEP Guidelines for Transmission Owner Identified Needs (AEP Assumptions Slide 8)

**Problem Statement:**

Elmridge Tap

- 3 terminal line outside of Elmridge Station.

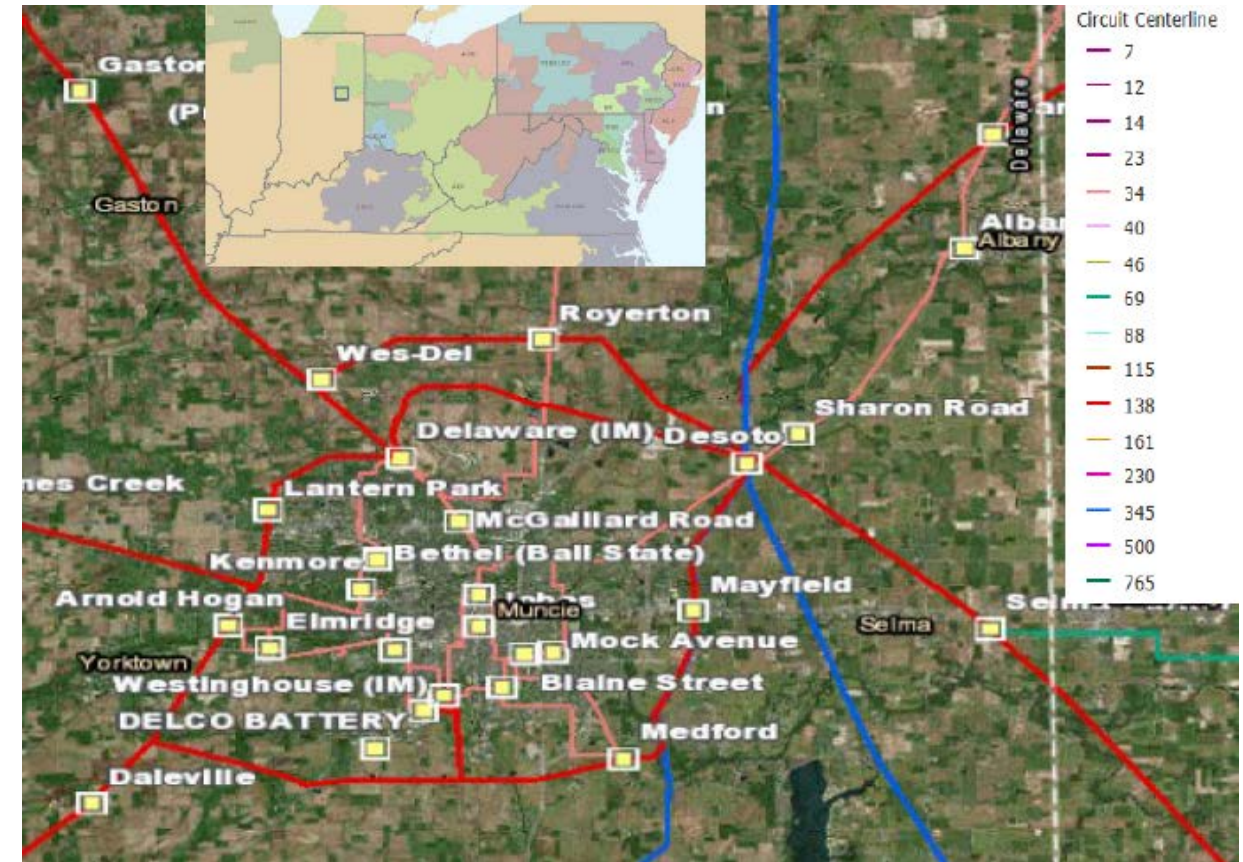



# AEP Transmission Zone M-3 Process Southern Muncie

**Need Number:** AEP-2018-IM007

**Process Stage:** Submission of Supplemental Project for inclusion in the Local Plan 8/29/2019

**Previously Presented:**

Needs Meeting 10/26/2019

Solution Meeting 1/11/2019

**Project Driver:**

Customer Service

**Specific Assumption Reference:**

Obligation to serve

**Problem Statement:**

Arnold Hogan Station

- AEP Distribution has requested a new delivery point at Arnold Hogan Station

Delco Battery Site

- AEP Distribution has requested a new delivery point at the old Delco site to facilitate the industrial load pocket
- Transmission has received multiple customer requests at the industrial park near Delco Battery Site

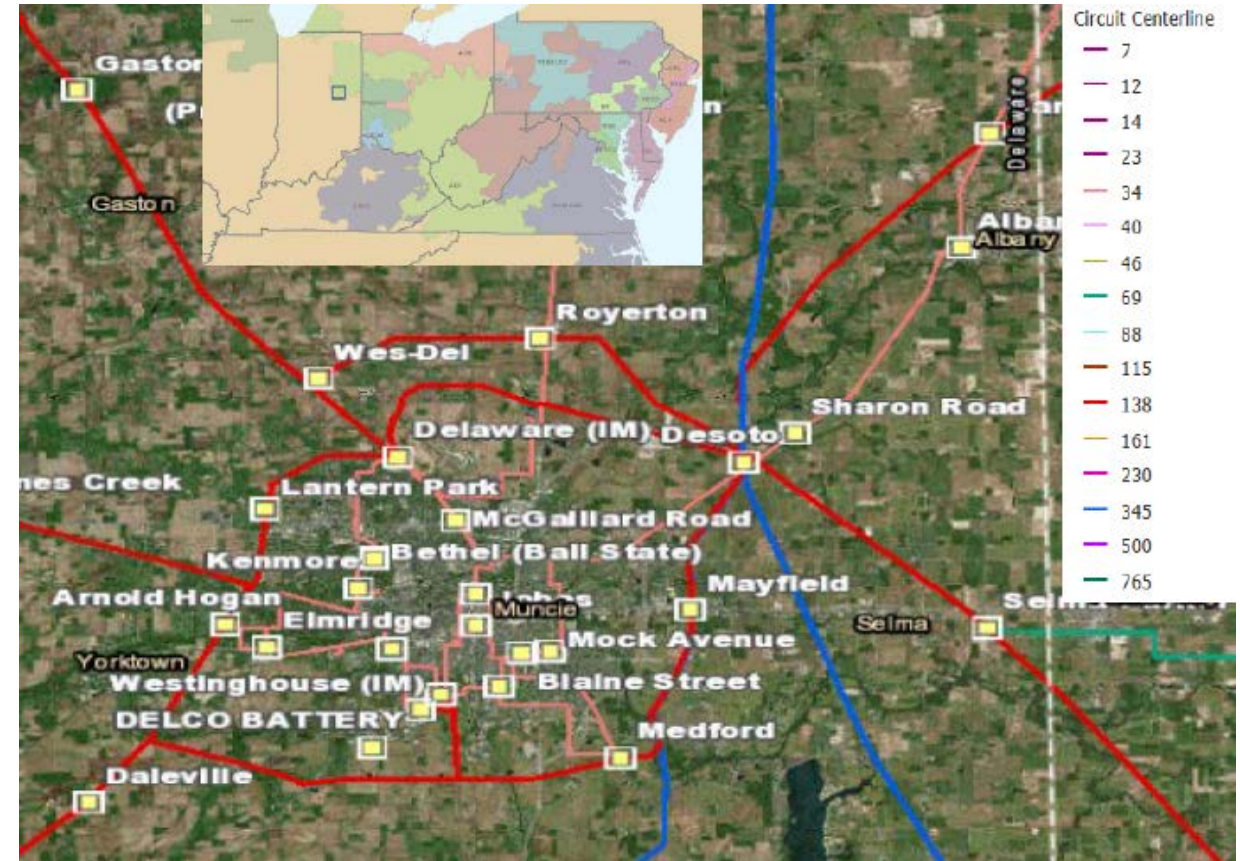

# AEP Transmission Zone M-3 Process Southern Muncie

**Need Number:** AEP-2018-IM007

**Process Stage:** Submission of Supplemental Project for inclusion in the Local Plan 8/29/2019

**Selected Solution:**

**Arnold Hogan**

Install a new Distribution transformer and bay. Replace existing transformer and install a switcher on both transformers. Rebuild the 138kV side as a breaker and a half with 3 new 138kV breakers. Rebuild the 34.5kV voltage class as a ring bus with a new 28.8Mvar cap bank. Estimated Cost: \$21.1M **(S1854.1)**

**Elmridge**

Retire Elmridge Station Estimated Cost: \$21.1M **(S1854.2)**

**23rd Street**

Rebuild the 34.5kV voltage class as a 6 breaker ring bus with 5 new 69kV rated breakers. Install 3 138kV breakers to form a ring bus on the high side. Retire the cap banks. Rebuild the underground line exits as overhead. Estimated Cost: \$11.9M **(S1854.3)**

**Medford** Rebuild station with a 3 breaker 69kV rated ring bus on the 34.5 side. Rebuild the high side as a 3 breaker 138kV ring bus. Replace the transformer with a 138/69/34.5kV bank. Retire the cap bank. Estimated Cost: \$15.6M **(S1854.4)**

**Blaine Street**

Retire breaker E and construct a new 69kV rated bus with a new 69kV rated breaker and distribution bank. Estimated Cost: \$0.4M **(S1854.5)**

**Fuson**

Build a new 138kV station with a 138kV bus tie breaker and 2 distribution banks to serve the Delco Battery site. Estimated Cost: \$3.1M **(S1854.6)**

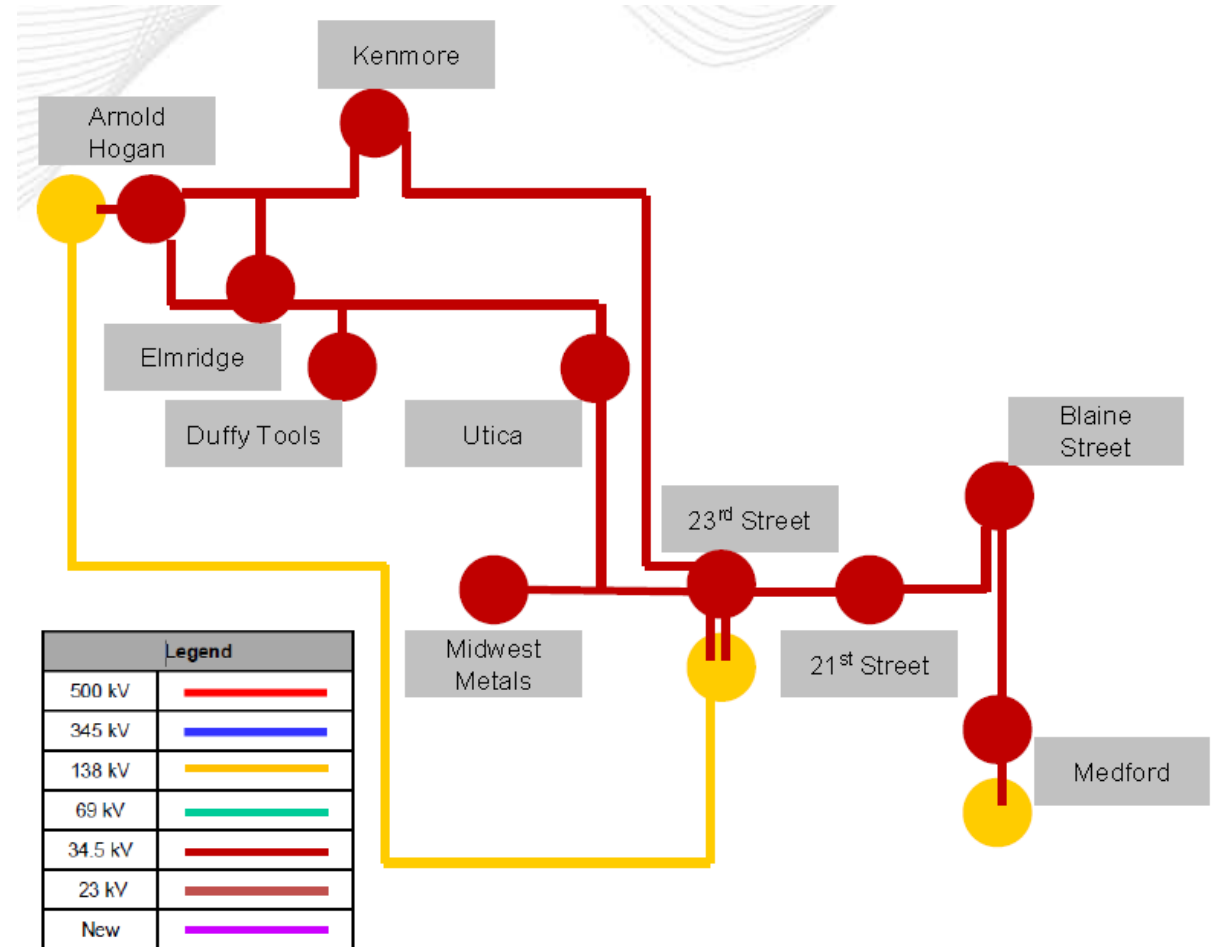

# AEP Transmission Zone M-3 Process Southern Muncie

**Need Number:** AEP-2018-IM007

**Process Stage:** Submission of Supplemental Project for inclusion in the Local Plan 8/29/2019

**Selected Solution:**

**Arnold Hogan – 23rd Street**

Rebuild from Arnold Hogan – STR 56 north of Utica using 556 ACSR. Estimated Cost: \$12.4M (**\$1854.7**)

**Fuson Tap**

Build a new 138kV line toward the Fuson station site using 1033.5 ACSR. Estimated Cost: \$4.0M (**\$1854.8**)

**Elmridge Tap**

Retire the Elmridge tap line. Estimated Cost: \$0.2M (**\$1854.9**)

**Total Estimated Cost:** \$68.7M

**Projected In-Service:** 6/1/2022

**Supplemental Project ID:** S1854.1 – S1854.9

**Project Status:** Scoping

**Model:** 2024 RTEP

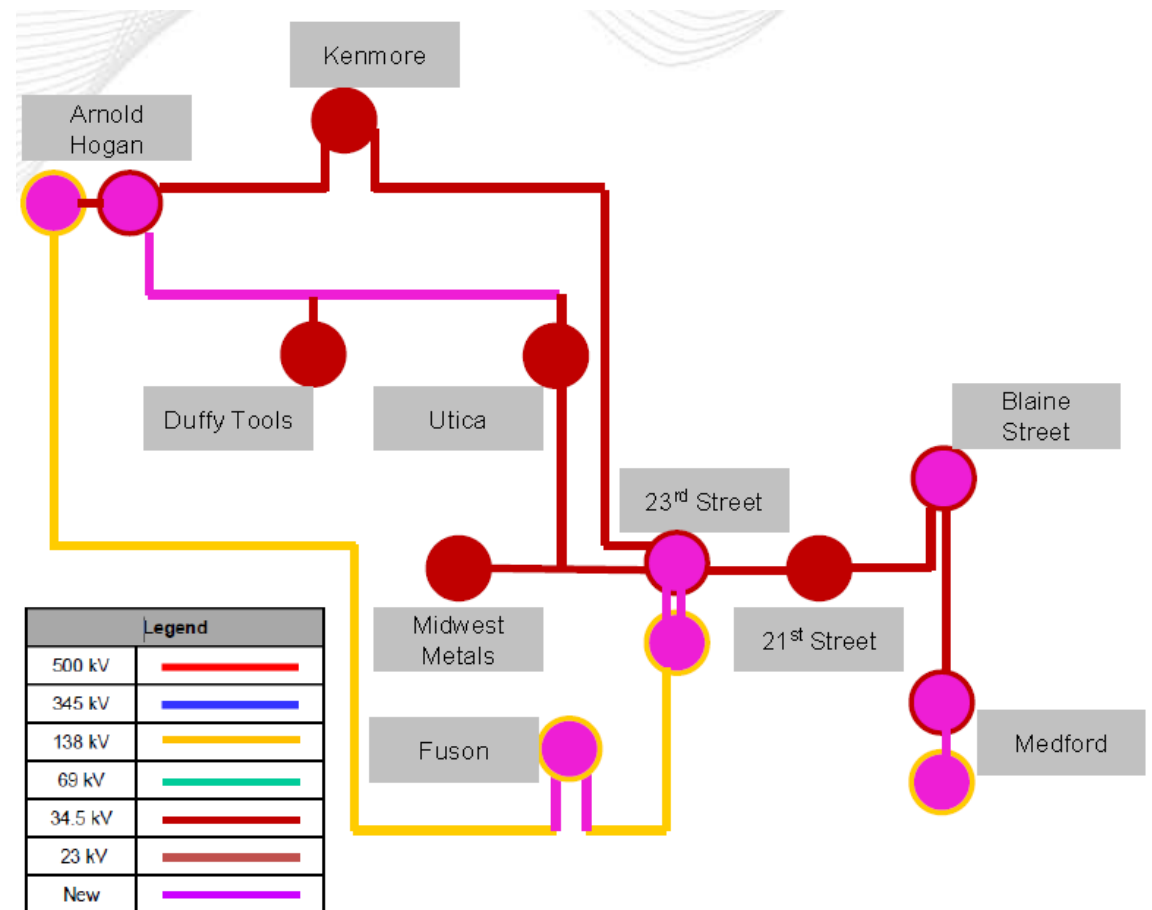

# AEP Transmission Zone M-3 Process Deer Creek - Delaware

**Need Number:** AEP-2018-IM008

**Process Stage:** Submission of Supplemental Project for inclusion in the Local Plan 8/29/19

**Previously Presented:**

Needs Meeting 10/26/18

Solution Meeting 2/20/2019

**Project Driver:**

Equipment Condition/Performance/Risk

**Specific Assumption Reference:**

AEP Guidelines for Transmission Owner Identified Needs (AEP Assumptions Slide 8)

**Problem Statement:**

Deer Creek – Delaware

- 1920's vintage steel lattice line.
- 397.5 ACSR Double Circuit
- 439 open structure and conductor category A and B conditions

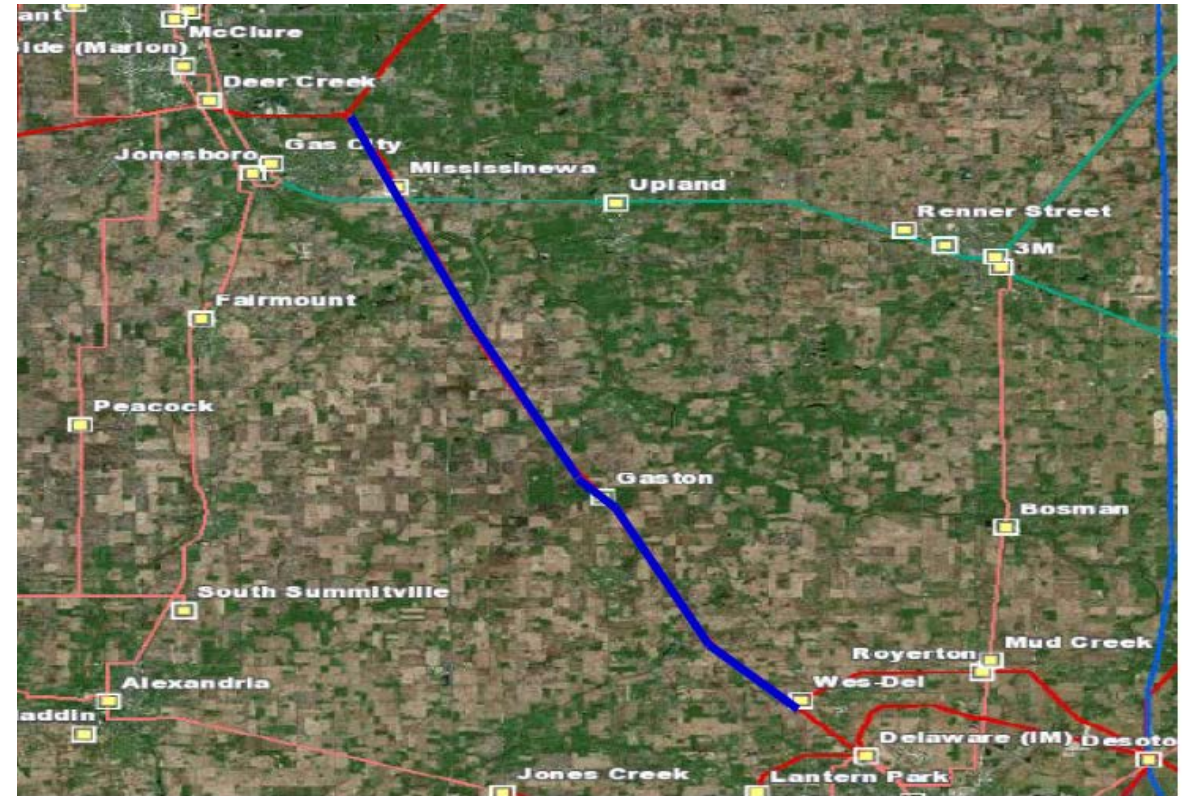

# AEP Transmission Zone M-3 Process Deer Creek - Delaware

**Need Number:** AEP-2018-IM008

**Process Stage:** Submission of Supplemental Project for inclusion in the Local Plan 8/29/19

**Selected Solution:**

**Deer Creek – Delaware:**

Rebuild the ~19.8 miles from structure 16 to structure 127 on the Deer Creek – Delaware double circuit 138kV line. Estimated Cost: \$56.1M (S1855.1)

**Gaston:**

Install a breaker facing Desoto in the bus tie position Estimated Cost: \$1.0M (S1855.2)

**Delaware:**

Reterminate into the P breaker Estimated Cost: \$0.2M (S1855.3)

**Total Estimated Cost:** \$57.3M

**Projected In-Service:** 10/8/2021

**Supplemental Project ID:** S1855.1 – S1855.3

**Project Status:** Scoping

**Model:** N/A

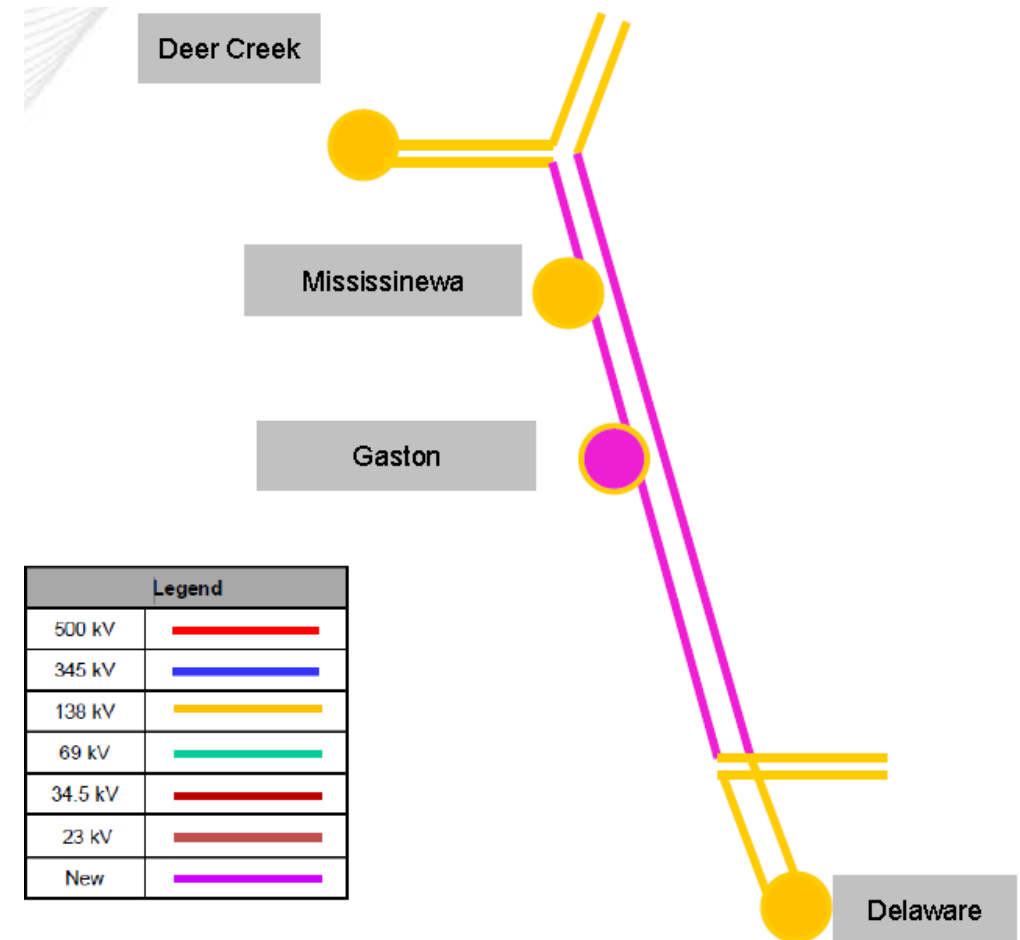

# AEP Transmission Zone M-3 Process Wapakoneta

**Need Number:** AEP-2018-OH001

**Process Stage:** Submission of Supplemental Project for inclusion in the Local Plan 8/29/2019

**Previously Presented:**

Needs Meeting 10/26/18

Solution Meeting 1/11/19

**Project Driver:**

Customer Service

**Specific Assumption Reference:**

AEP Guidelines for Transmission Owner Identified Needs (AEP Assumptions Slide 7)

**Problem Statement:**

Obligation to serve new customer load for the City of Wapakoneta. Total future load expected to be served from Gemini station is approx. 127MW.

The total 127 MW future load includes an additional estimated 40MW of new load from other new potential customers at the same location.

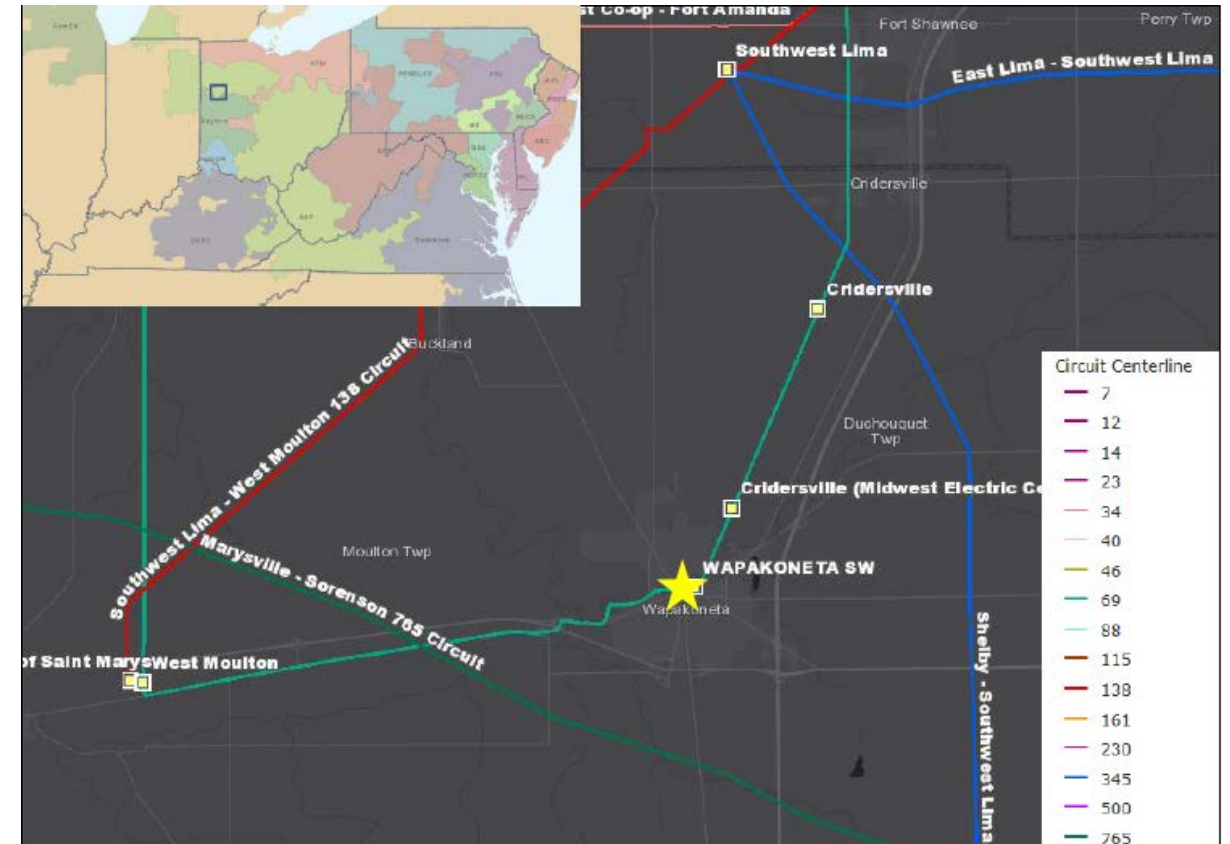

# AEP Transmission Zone M-3 Process Wapakoneta

**Need Number:** AEP-2018-OH001

**Process Stage:** Submission of Supplemental Project for inclusion in the Local Plan 8/29/2019

**Selected Solution:**

Build a new 345/138 kV Gristmill Station cutting into the Southwest Lima – Shelby 345 kV line. Estimated Cost: \$25.8M (**\$1856.1**)

Build a new 138 kV Gemini Station southeast of the City of Wapakoneta to serve the load request. Estimated Cost: \$8.9M (**\$1856.2**)

Build a new 138 kV line connecting Gristmill to Gemini Stations. Estimated Cost: \$9.8M (**\$1856.3**)

Build a new 138 kV line from the new 138 kV Gemini Station to existing West Moulton 138 kV Station. Rebuild the West Moulton 138 kV Station as a 4 breaker ring bus. Estimated Cost: \$14.7M (**\$1856.4**)

Remove the existing City of St Marys hard tap off the Southwest Lima – West Moulton 138 kV line and bring it into West Moulton 138 kV station (~0.2 mi away). Estimated Cost: \$7.0M (**\$1856.5**)

**Total Estimated Cost:** \$66.2M

**Projected In-Service:** 12/31/2020

**Supplemental Project ID:** S1856.1 – S1856.5

**Project Status:** Engineering

**Model:** 2024 RTEP

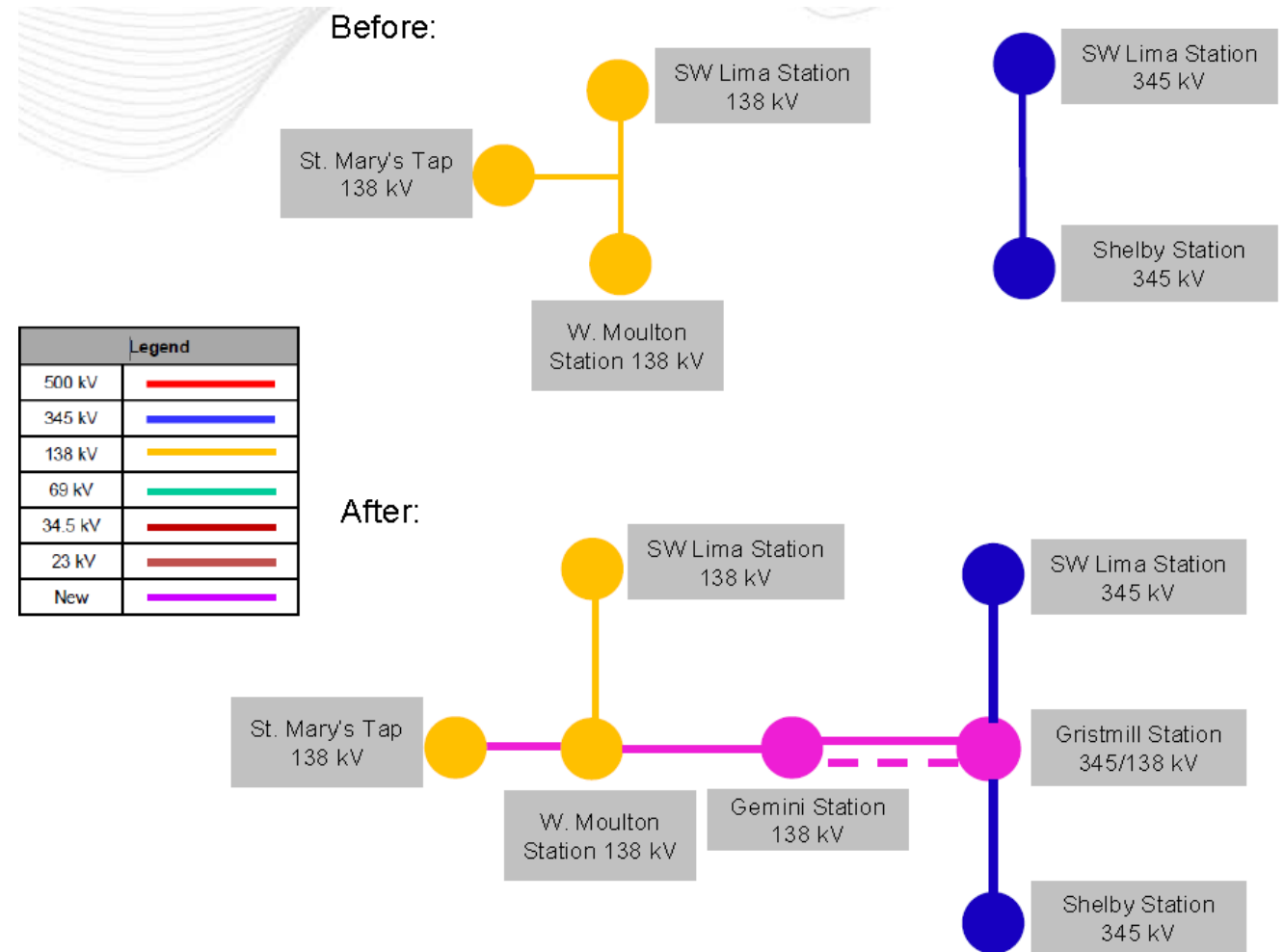

The page is intentionally left in blank.



The page is intentionally left in blank.

# AEP Transmission Zone M-3 Process Harmar Hill

**Need Number:** AEP-2018-OH009

**Process Stage:** Submission of Supplemental Project for inclusion in the Local Plan 8/29/19

**Previously Presented:**

Needs Meeting 10/28/18  
Solution Meeting 2/20/19

**Project Driver:**

Operational Flexibility and Efficiency, Customer Service.

**Specific Assumption Reference:**

Equipment Condition, Operational Flexibility

**Problem Statement:**

RJF is a customer owned substation that is served off a 138kV hard tap. Harmar Hill is served from a tap with a one way switch. Any line work along between Mill Creek and Gorsuch causes considerable outages to both customer loads. There is limited transfer capability at Harmar Hill and no transfer capability for RJF. AEP's internal guidelines justify sectionalizing on this line (FOI: 10.17).

Mill Creek will be replaced by a new substation Devola as part of an unrelated project (S1125).

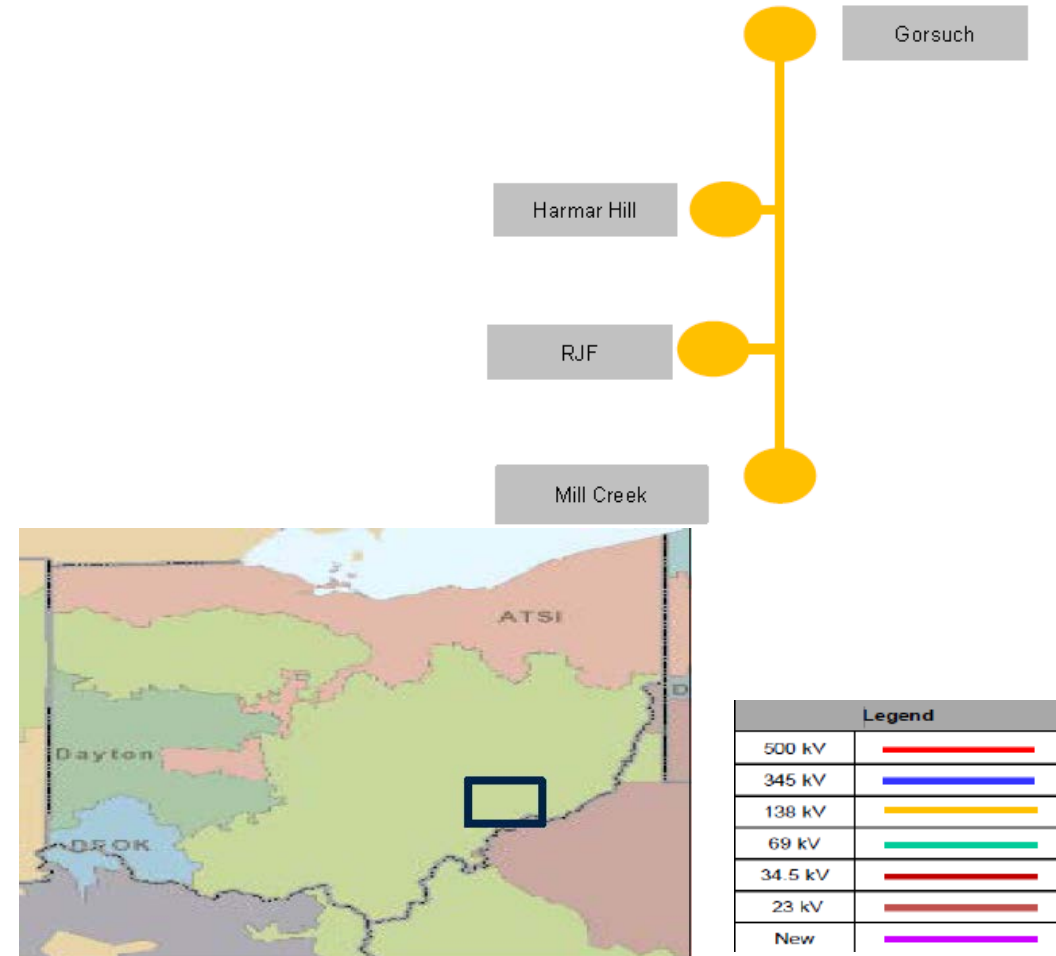

# AEP Transmission Zone M-3 Process Harmar Hill

**Need Number:** AEP-2018-OH009

**Process Stage:** Submission of Supplemental Project for inclusion in the Local Plan 8/29/19

**Selected Solution:**

Install a 3-way, SCADA-controlled phase-over-phase switch at Harmar Hill to replace the one-way line switch on the Gorsuch – Mill Creek 138 kV circuit.

**Estimated Cost:** \$1.35M

**Projected In-Service:** 6/1/2020

**Supplemental Project ID:** S1858

**Project Status:** Scoping

**Model:** 2024 RTEP

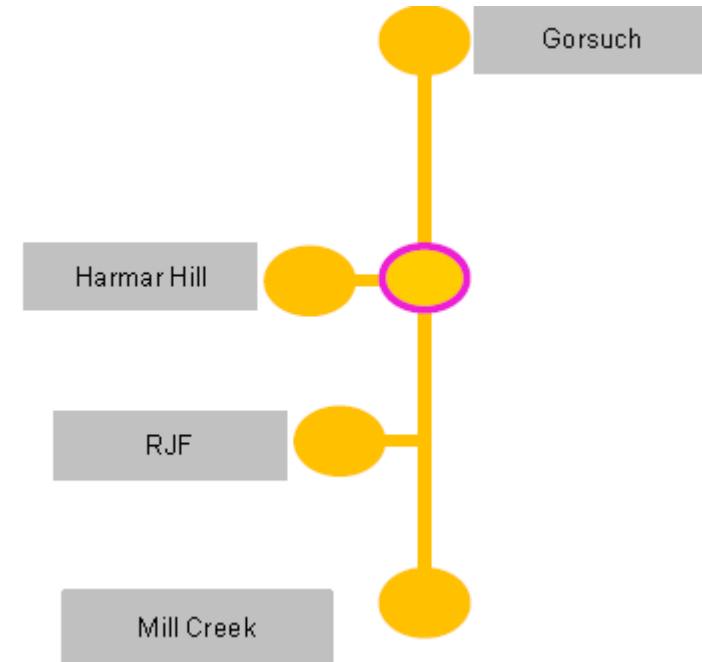

# AEP Transmission Zone M-3 Process Gable-Carrollton

**Need Number:** AEP-2018-OH011

**Process Stage:** Submission of Supplemental Project for inclusion in the Local Plan 8/29/19

**Previously Presented:**

Needs Meeting 10/26/18

Solutions Meeting 1/11/19

**Project Driver:**

Equipment Material/Condition/ Performance/Risk

**Specific Assumption Reference:**

AEP Guidelines for Transmission Owner Identified Needs (AEP Assumptions Slide 8)

**Problem Statement:**

The 29-mile Gable-Carrollton 138kV circuit (vintage 1917) is in poor condition and is a reliability risk to the transmission system. The circuit consists of lattice towers and 6-wired 200 kcmil copper conductor. After a century in the field, the lattice towers have degraded significantly, with heavy rusting and broken tower legs. The copper conductor has become very brittle and is difficult for crews to repair. Some towers are sitting in water. The suspension insulators and hardware are also heavily worn.

The circuit has 39 open conditions, with the majority being structural issues (e.g., degraded tower parts & broken insulators). The circuit has experienced 5 outages in the last 3 years (2016-2018 YTD), including a 50-hour outage due to broken conductor.

This circuit spans the center of the Ohio Utica shale gas region in Carroll/ Harrison Counties, with major activity from existing industrial customers and frequent economic development inquiries for future loads (e.g., pipeline compressor stations & midstream processing plants).

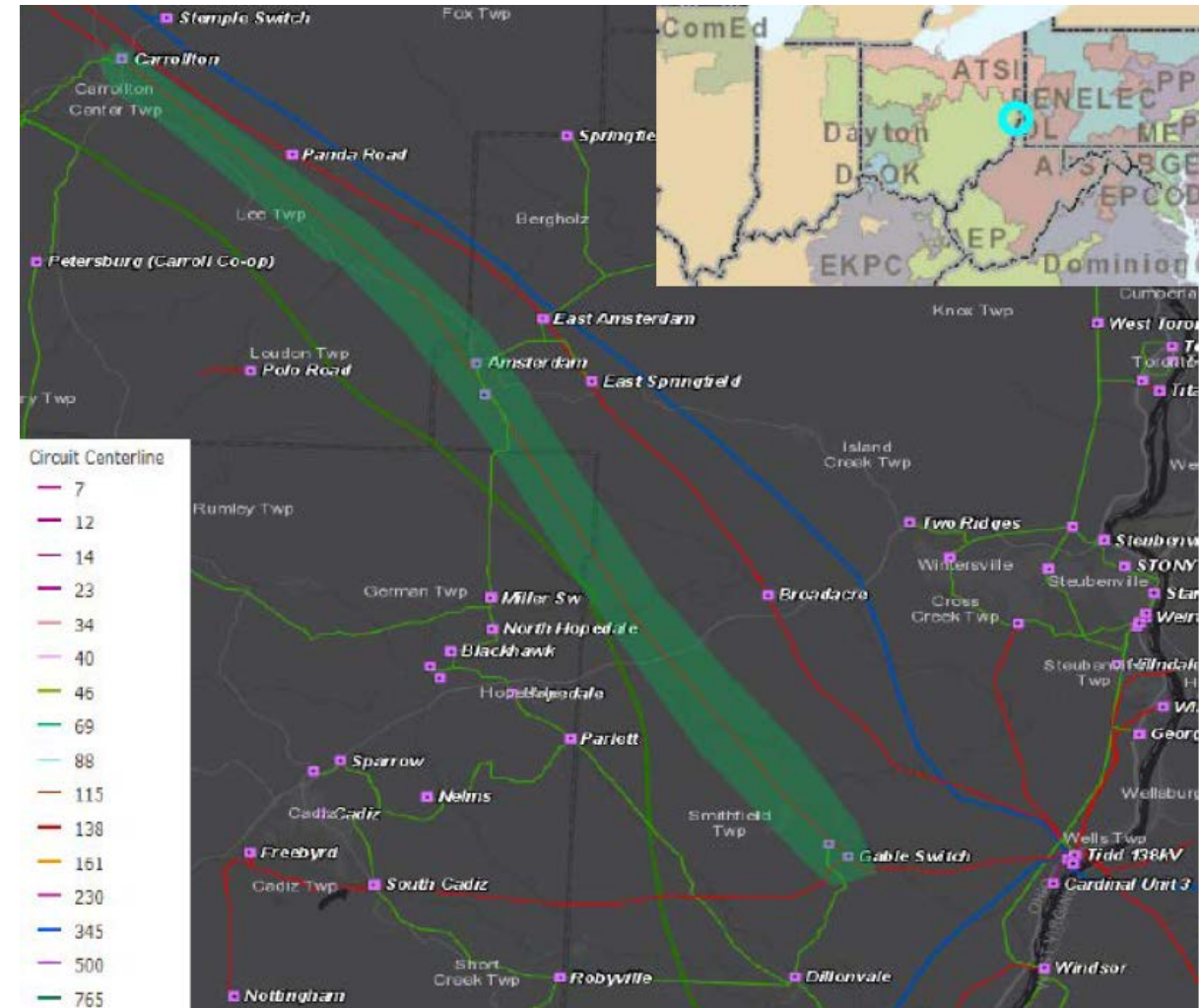

# AEP Transmission Zone M-3 Process Gable-Carrollton

**Need Number:** AEP-2018-OH011

**Process Stage:** Submission of Supplemental Project for inclusion in the Local Plan 8/29/19

**Selected Solution:**

Rebuild the 29-mile Gable-Carrollton 138kV circuit. Remove double-circuit lattice towers with 6-wired 200 kcmil CU. Install double-circuit steel poles with 6-wired 1234 ACSS/TW Yukon conductor.

Note that the other 2 segments of this 138kV pathway are already being rebuilt similarly: Tidd-Gable 138kV (in-service, S1067) and Carrollton-Sunnyside 138kV (in-construction, S1425).

Rebuilding the circuit as 6-wired permits AEP to maximize the use of its right-of-way in this region, which has major activity from oil & gas pipeline expansion competing for right-of-way. Installing a larger conductor permits future customer expansion in this area in the heart of the Utica shale gas play. In addition, this option permits the circuit to be split into two 138kV circuits when the need arises.

**Estimated Cost:** \$42.1M

**Projected In-Service:** 11/01/2021

**Supplemental Project ID:** S1859

**Project Status:** Engineering

**Model:** N/A

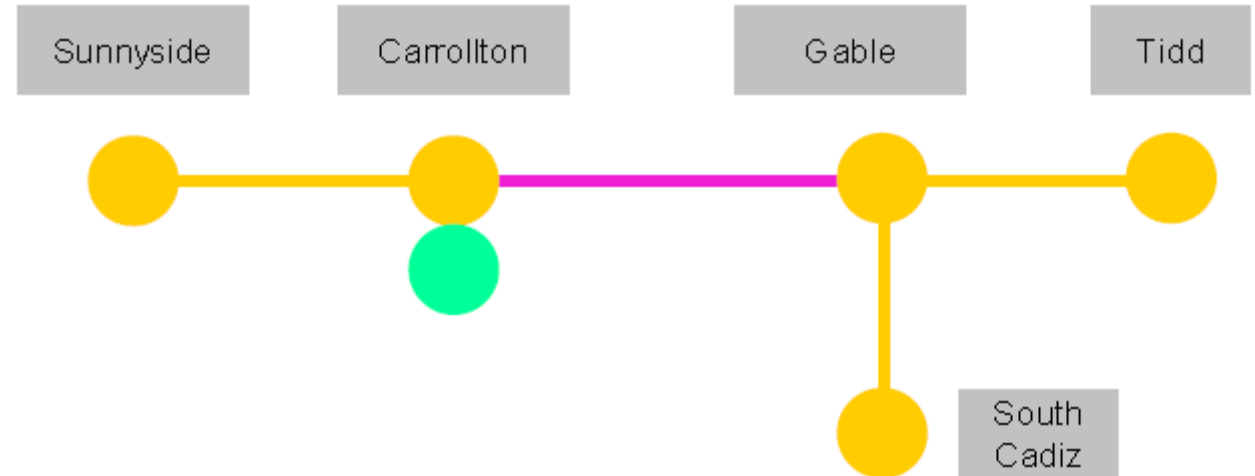

Legend	
500 kV	
345 kV	
138 kV	
69 kV	
34.5 kV	
23 kV	
New	

**Need Number:** AEP-2018-OH014

**Process Stage:** Submission of Supplemental Project for inclusion in the Local Plan 8/29/19

**Previously Presented:**

Needs Meeting 10/26/18

Solutions Meeting 1/11/19

**Project Driver:**

Operational Flexibility and Efficiency, Customer Service

**Specific Assumption Reference:**

AEP Guidelines for Transmission Owner Identified Needs (AEP Assumptions Slide 7 and 8)

**Problem Statement:**

Reno Substation is served off a 138kV hard tap. If there is an outage, planned or unplanned on the line sections between Belmont and Levee, the Reno load will be dropped. There is partial transfer capability for Reno during light load periods only. Levee Station cannot take all Reno's load because the distribution circuits are over five miles between the two stations dictated by geography.

The nearby Wade station is being retired as part of an area project to address an unreliable 23 kV system. Levee Station will take a portion of Wade's load and the remaining load will be served from Reno Station.



**Need Number:** AEP-2018-OH014

**Process Stage:** Submission of Supplemental Project for inclusion in the Local Plan 8/29/19

**Selected Solution:**

At Reno, install a 3-way switch at the hard tap, and fiber and SCADA, and relocate a pole.

**Estimated Cost:** \$2.56M

**Projected In-Service:** 6/1/2019

**Supplemental Project ID:** S1860

**Project Status:** Engineering

**Model:** 2024 RTEP

**Existing**

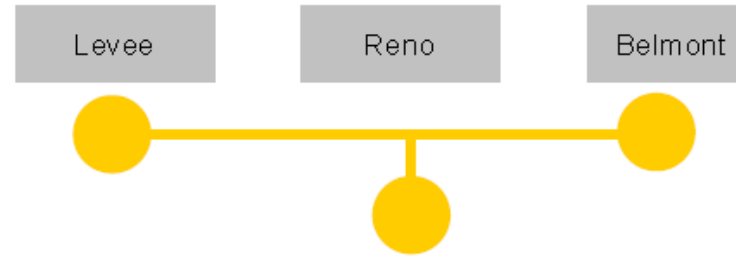

**Proposed**

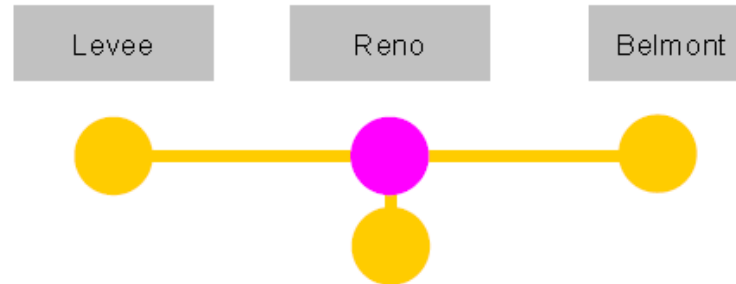

Legend	
500 kV	
345 kV	
138 kV	
69 kV	
34.5 kV	
23 kV	
New	

**Need Number:** AEP-2018-OH019

**Process Stage:** Submission of Supplemental Project for inclusion in the Local Plan 8/29/19

**Previously Presented:**

Needs Meeting 11/29/18

Solution Meeting 3/25/19

**Project Driver:**

Customer Service

**Specific Assumption Reference:**

AEP Connection Requirements for the AEP Transmission System

**Problem Statement:**

A transmission customer has requested new 69kV service on the northeast side of Wooster, Ohio. The total peak demand is 11 MVA.

The customer is paying to install a 2nd 69kV power transformer in their station and need a 2nd 69kV service point from AEP Transmission.

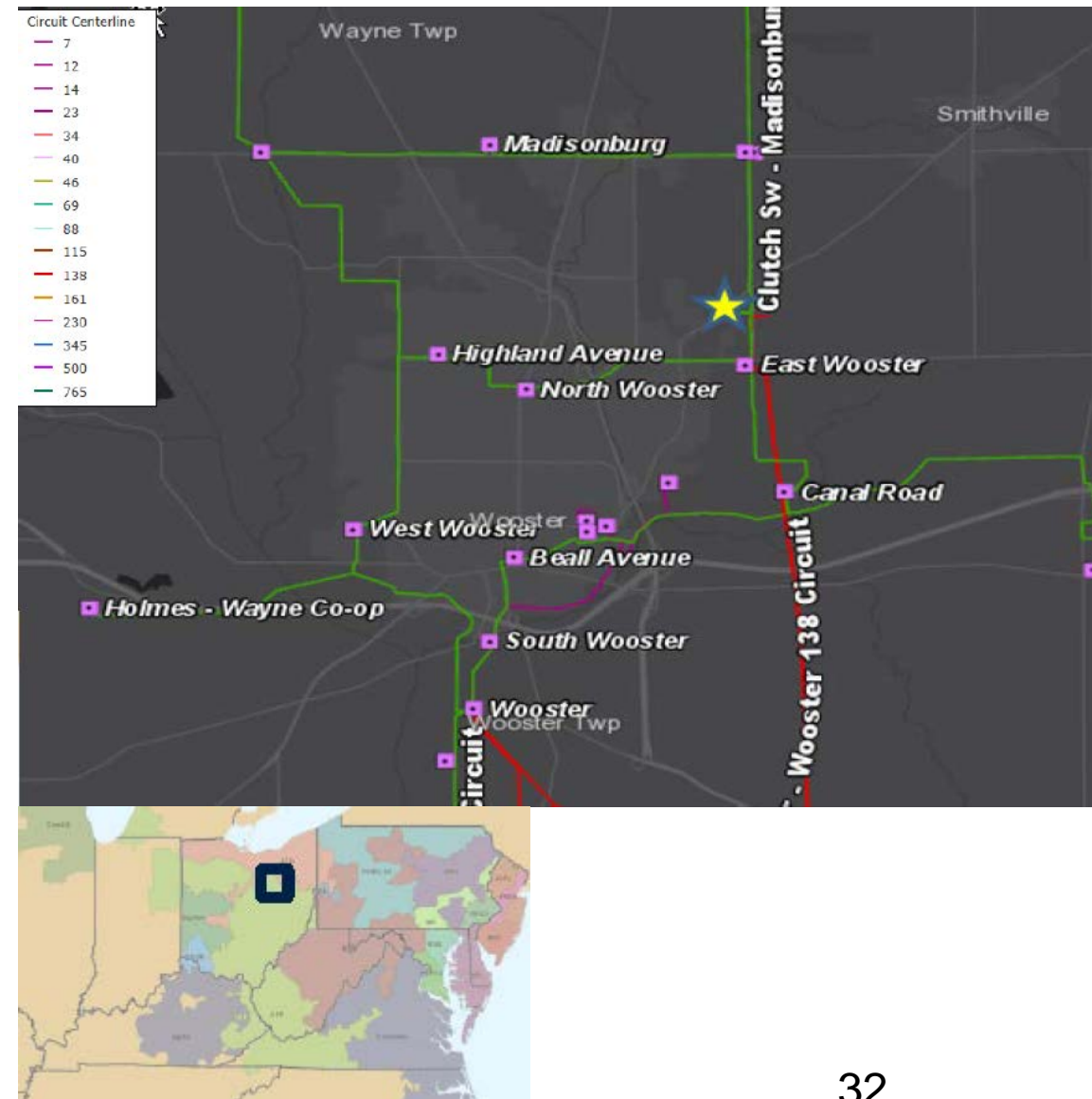



**Need Number:** AEP-2018-OH019

**Process Stage:** Submission of Supplemental Project for inclusion in the Local Plan 8/29/19

**Selected Solution:**

**Clutch Switch 69kV:** Extend a 2nd 69kV service to the customer (1 span) to serve their 2nd transformer. Install a 2nd set of 69kV revenue metering equipment. Install a 69kV bus-tie breaker at Clutch Switch station, separating the two feeds to the customer.

**Estimated Cost:** \$0.7M

**Projected In-Service:** 7/7/19

**Supplemental Project ID:** S1861

**Project Status:** Scoping

**Model:** 2024 RTEP

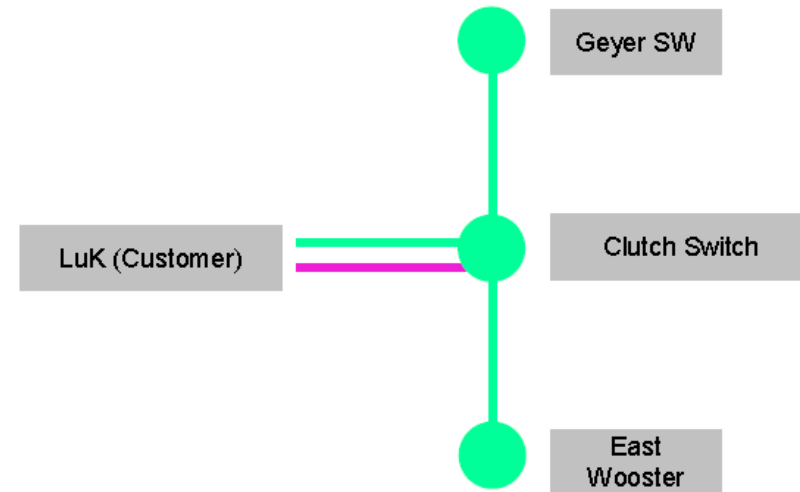

Legend	
500 kV	
345 kV	
138 kV	
69 kV	
34.5 kV	
23 kV	
New	

# AEP Transmission Zone M-3 Process Baltimore-Lancaster

**Need Number:** AEP-2018-OH021

**Process Stage:** Submission of Supplemental Project for inclusion in the Local Plan 8/29/19

**Previously Presented:**

Needs Meeting 11/29/18

Solutions Meeting 1/11/19

**Project Driver:**

Customer Request

**Specific Assumption Reference:**

AEP Guidelines for Transmission Owner Identified Needs

**Problem Statement:**

- Baltimore 69kV CBs E and F are oil type breakers (vintage 1951) and have been identified for replacement due to lack of spare part availability, historical reliability, and lack of vendor support. Oil breakers are difficult to maintain due to oil handling requirements. Oil spills can occur during maintenance and fixes. The breakers have experienced the following fault operations: CB E (5), CB F (5).
- Baltimore currently has 20 electro-mechanical relays employed. EM relays have limited spare part availability, a lack of vendor support, no SCADA functionality, and no fault data collection ability.
- Lancaster 69kV CBs B and D are oil type breakers (vintage 1989) and have been identified for replacement due to lack of spare part availability, historical reliability, and lack of vendor support. Oil breakers are difficult to maintain due to oil handling requirements. Oil spills can occur during maintenance and fixes. The breakers have experienced the following fault operations: CB B (4), CB D (18).
- Lancaster currently has 46 electro-mechanical relays employed. EM relays have limited vendor support, lack of SCADA functionality, and don't offer fault data collection

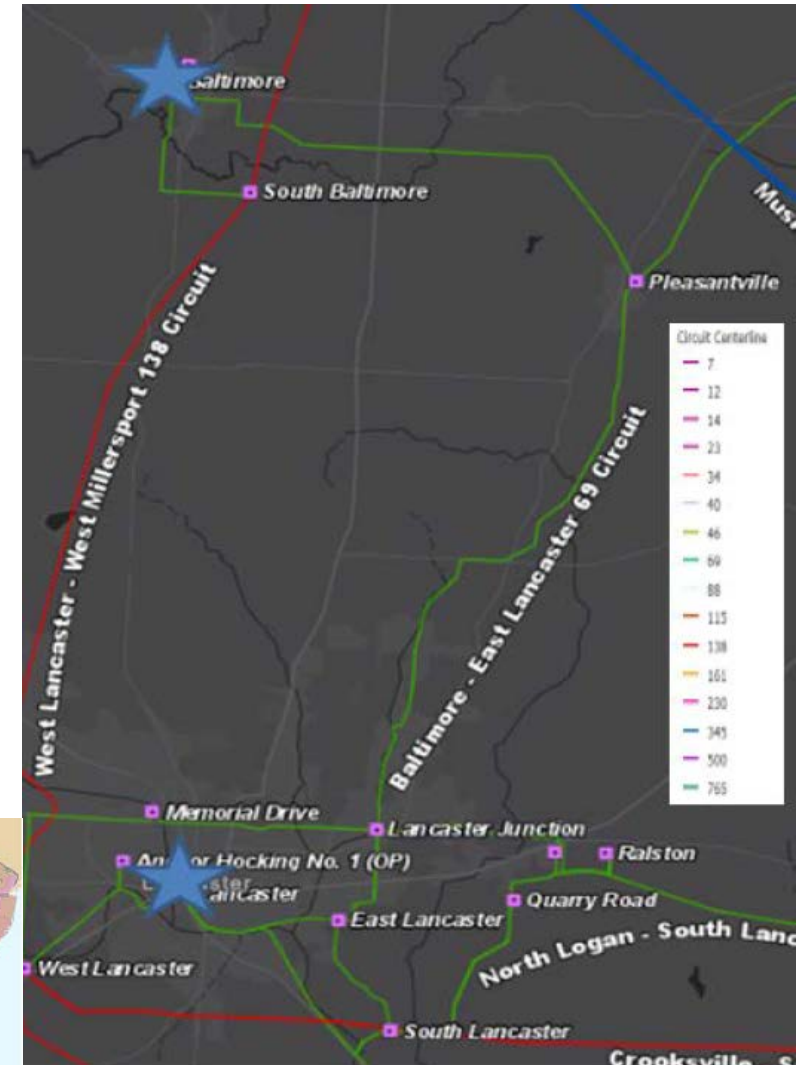

# AEP Transmission Zone M-3 Process Baltimore-Lancaster

**Need Number:** AEP-2018-OH021

**Process Stage:** Submission of Supplemental Project for inclusion in the Local Plan 8/29/19

**Selected Solution:**

At Lancaster station, replace existing 69 kV CB B and CB D with new non-oil breakers and upgrade relaying at the station. Estimated cost: \$3.02M **S1862.1**

At Baltimore station, replace existing CBs E and F with new non-oil breakers and upgrade relaying at station. Estimated cost: \$2.21M **S1862.2**

**Total Estimated Cost:** \$5.23M

**Projected In-Service:** 12/15/2019

**Supplemental Project ID:** S1862.1 & S1862.2

**Project Status:** Engineering

**Model:** 2024 RTEP

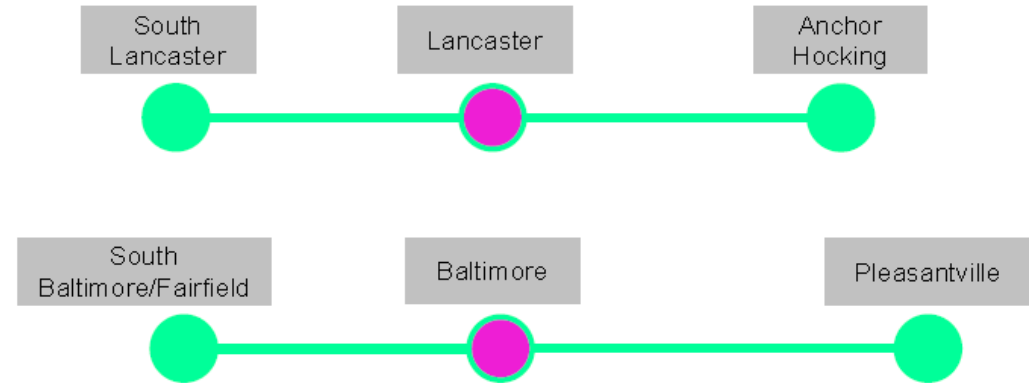

Legend	
500 kV	
345 kV	
138 kV	
69 kV	
34.5 kV	
23 kV	
New	

**Need Number:** AEP-2018-OH022

**Process Stage:** Submission of Supplemental Project for inclusion in the Local Plan 8/29/19

**Previously Presented:**

Needs Meeting 11/29/18

Solution Meeting 2/20/19

**Project Driver:**

Equipment Material/Condition/Performance/Risk

**Specific Assumption Reference:**

AEP Guidelines for Transmission Owner Identified Needs (AEP Assumptions Slide 8)

**Problem Statement:**

- Cyclops 69kV circuit switcher A is currently being used as a line CB. This model has limited spare parts availability and reliability concerns. This circuit switcher has also experienced 41 fault operations.
- Cyclops 69kV CB B is an oil type breaker (vintage 1955) that has exceeded the manufacturers recommended number of fault operations (36 total faults). Oil breakers are difficult to maintain due to oil handling requirements. Oil spill can occur during maintenance and fixes.
- Cyclops station currently has 19 electro-mechanical relays employed.
- Cyclops station is currently built upon a four-pole wooden bay that is progressively deteriorating.



**Need Number:** AEP-2018-OH022

**Process Stage:** Submission of Supplemental Project for inclusion in the Local Plan 8/29/19

**Selected Solution:**

- Build a new greenfield station with an in-and-out configuration utilizing two 69 kV 3000 A 40 kA CB's.
- Install a new control house, relaying, and required bus work.
- T-Line work to reconnect the lines to the new Station.
- Removal of the old (Cyclops) Station.

**Estimated Cost:** \$5.3M

**Projected In-Service:** 6/15/19

**Supplemental Project ID:** S1863

**Project Status:** Engineering

**Model:** N/A

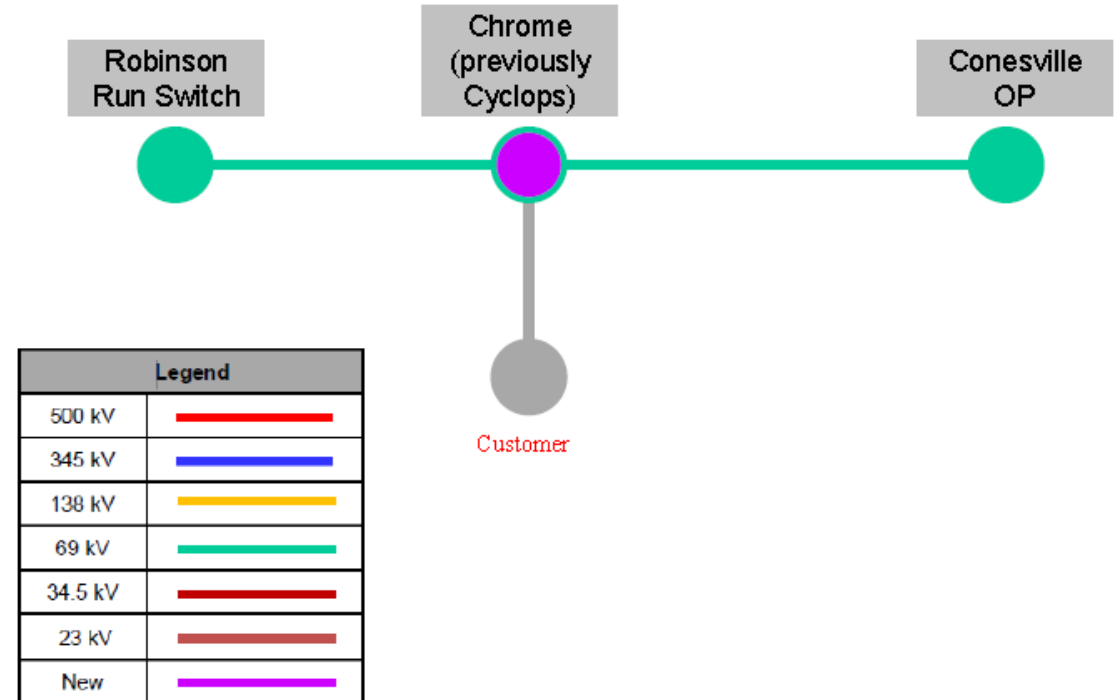

**Need Number:** AEP-2018-OH023

**Process Stage:** Submission of Supplemental Project for inclusion in the Local Plan 8/29/19

**Previously Presented:**

Needs Meeting 11/29/18

Solution Meeting 2/20/19

**Project Driver:**

Customer Request

**Specific Assumption Reference:**

AEP Guidelines for Transmission Owner Identified Needs (AEP Assumptions Slide 8)

**Problem Statement:**

- East Cambridge 34.5kV CB "D", 69kV CB "A" and 69kV CB "C" are vintage (1970-1975) circuit breakers. Oil breakers are difficult to maintain due to oil handling requirements and risk of oil spills during maintenance and failures. In addition, these CB's have exceeded the manufacturers recommended fault operations: CB A (8), CB C (28), and CB D (91).
- East Cambridge circuit switcher AA (vintage 1970) is recommended for replacement due to reliability concerns and lack of spare part availability.
- East Cambridge currently has 36 electro-mechanical relays employed.

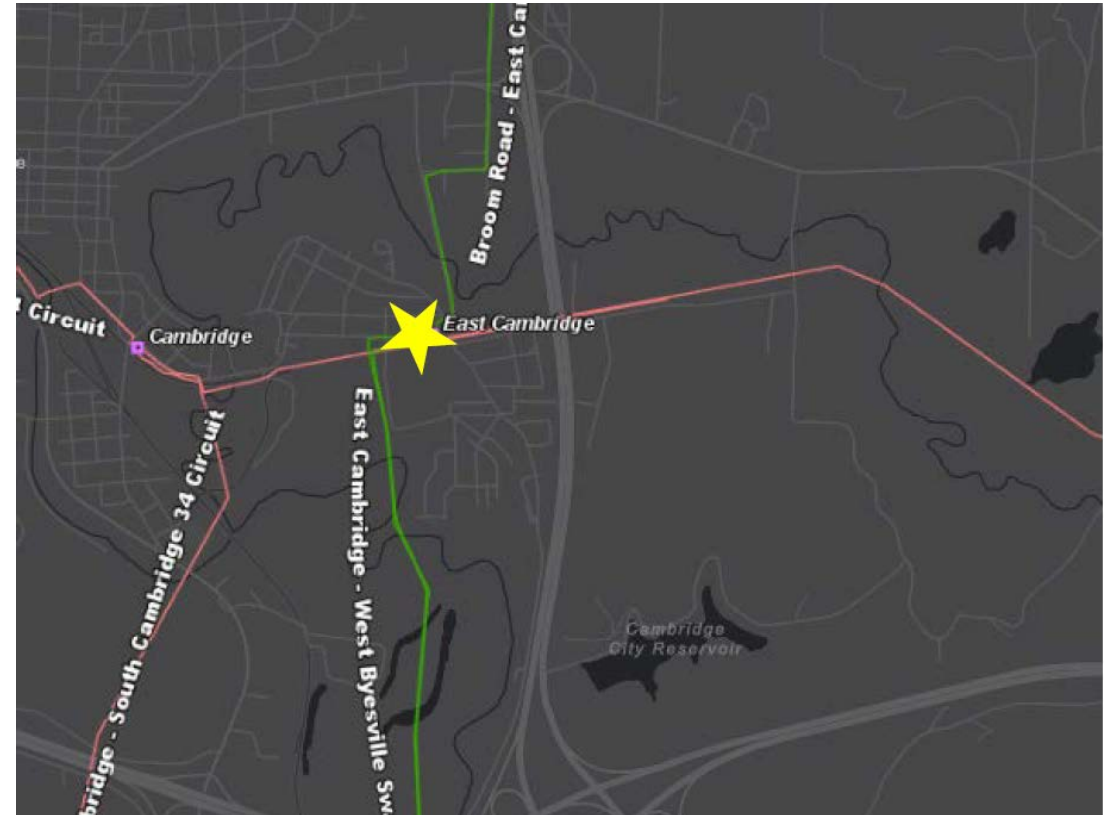

# AEP Transmission Zone M-3 Process East Cambridge

**Need Number:** AEP-2018-OH023

**Process Stage:** Submission of Supplemental Project for inclusion in the Local Plan 8/29/19

**Selected Solution:**

- Rebuild East Cambridge Station into a 69kV, 6-circuit-breaker ring bus with 69 kV 3000 A 40 kA breakers.
- Install a low side 34.5 kV 1200 A 25 kA circuit breaker on transformer #1.
- A new control house, new bus work, and new line relaying will be installed.
- T-Line work needed to reconnect the lines into the new Station.

**Estimated Cost:** \$13.32M

**Projected In-Service:** 12/15/2019

**Supplemental Project ID:** S1864

**Project Status:** Engineering

**Model:** 2024 RTEP

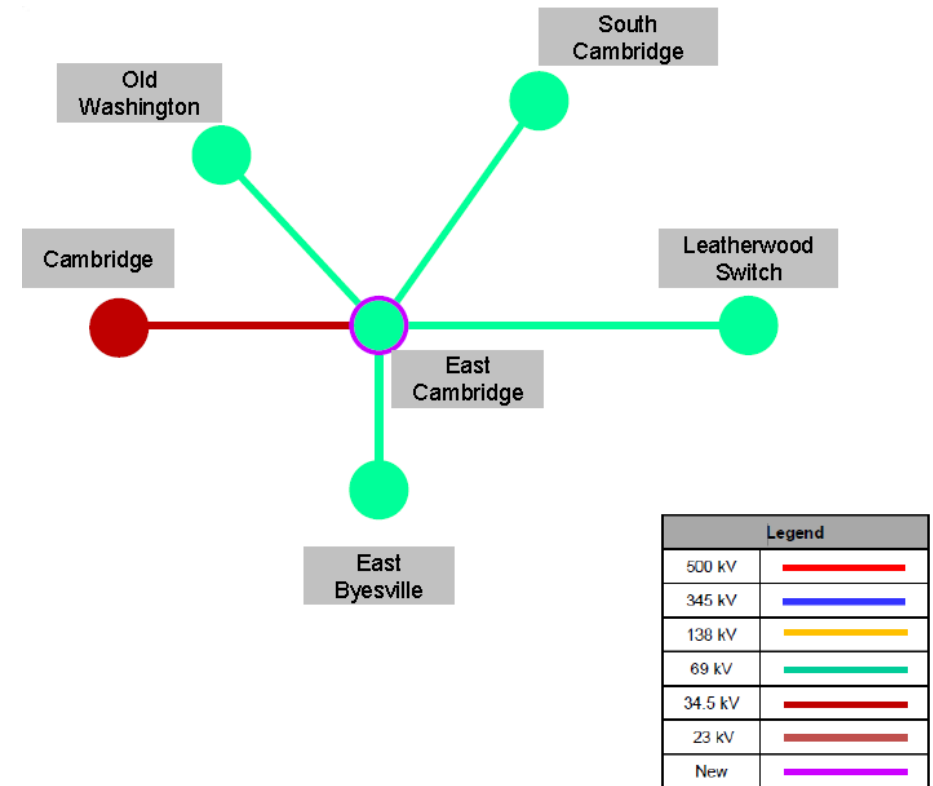

# AEP Transmission Zone M-3 Process Hocking

**Need Number:** AEP-2018-OH025

**Process Stage:** Submission of Supplemental Project for inclusion in the Local Plan 8/29/19

**Previously Presented:**

Needs Meeting 11/29/18

Solution Meeting 1/11/19

**Project Driver:**

Equipment Material/Condition/Performance/Risk

**Specific Assumption Reference:**

AEP Guidelines for Transmission Owner Identified Needs (AEP Assumptions Slide 8)

**Problem Statement:**

- Hocking 138kV MOAB "W" is in a failed state. When operating, arcing occurs, resulting in the tripping of remote breakers/circuit switchers.
- The structures supporting this MOAB will not allow for a like for like replacement due to the extra weight.

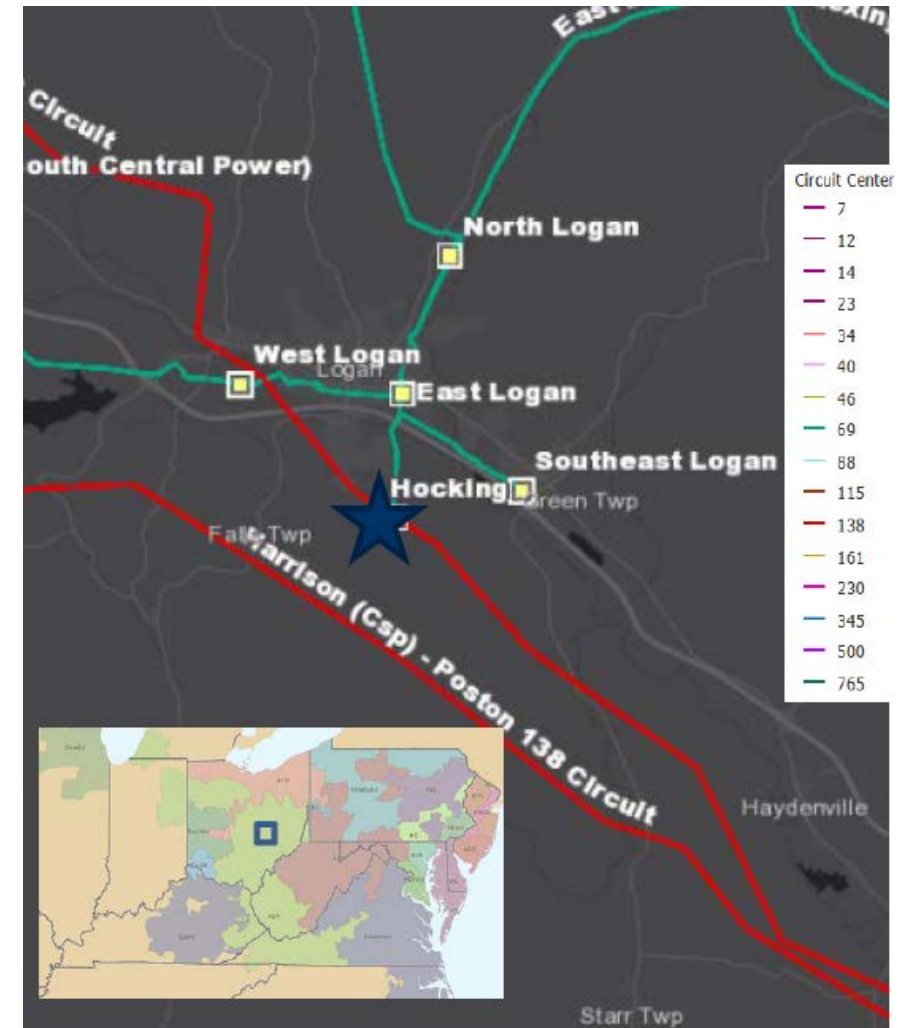



**Need Number:** AEP-2018-OH025

**Process Stage:** Submission of Supplemental Project for inclusion in the Local Plan 8/29/19

**Selected Solution:**

Replace the existing 138 kV MOAB "W" with a 3000 A/63 kA breaker. Historically, operating this MOAB has resulted in the tripping of the 138 kV circuit breaker "A" and 69 kV circuit breaker "C" at Hocking due to a phase-to-phase fault. The structure supporting this MOAB doesn't allow for it to be replaced by a vertical-break switch due to the extra weight on the structure. Hocking Station was designed to allow the installation of a circuit breaker in the future. In addition, this circuit breaker eliminates three dissimilar protection zones (bus, transformer and line).

**Estimated Cost:** \$753K

**Projected In-Service:** 3/11/2019

**Supplemental Project ID:** S1865

**Project Status:** In Service

**Model:** N/A

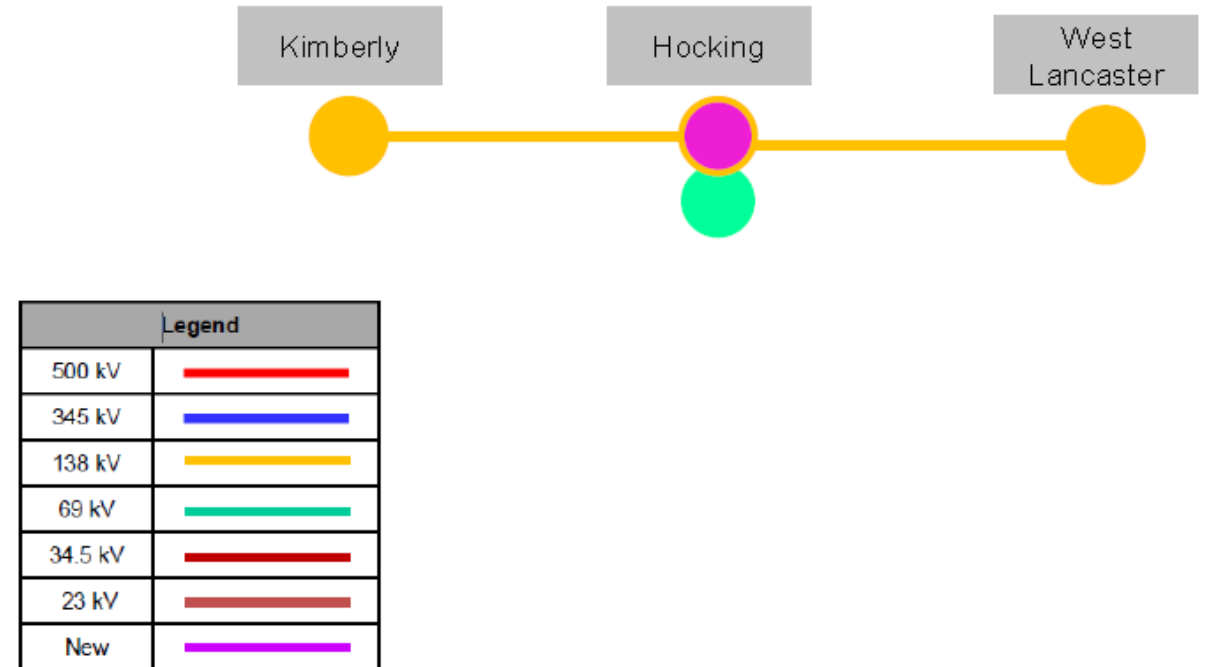

# AEP Transmission Zone M-3 Process East Logan – New Lexington

**Need Number:** AEP-2018-OH026

**Process Stage:** Submission of Supplemental Project for inclusion in the Local Plan 8/29/19

**Previously Presented:**

Needs Meeting 11/29/18

Solution Meeting 3/25/19

**Project Driver:**

Equipment Material/Condition/Performance/Risk

**Specific Assumption Reference:**

AEP Guidelines for Transmission Owner Identified Needs

**Problem Statement:**

- The New Lexington – East Logan 22.3 mile 69 kV (vintage 1916) was built using wood pole structures with conductors ranging from #1 Copper 3 conductor (31 MVA rating) to 336.4 KCM ACSR 18/1 (73 MVA rating).
- There are 333 open A conditions on this line, including burnt/broken conductors, and broken structures. The New Lexington – East Logan 69 kV circuit has experienced over three million customer minutes of interruption in the past three years.

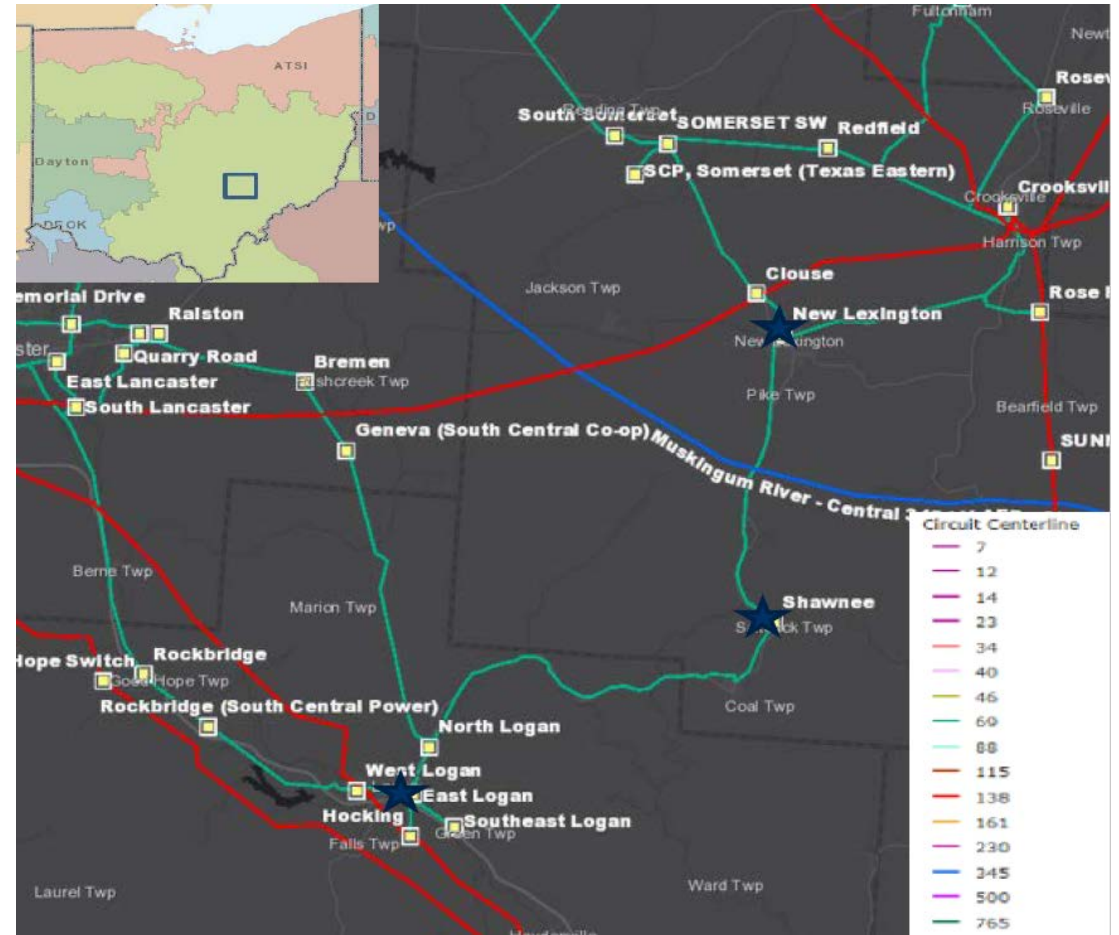

# AEP Transmission Zone M-3 Process East Logan – New Lexington

**Need Number:** AEP-2018-OH026

**Process Stage:** Submission of Supplemental Project for inclusion in the Local Plan 8/29/19

**Selected Solution:**

**Transmission Line Description:**

- Rebuild approximately 8.7 miles of the East Logan-New Lexington 69 kV circuit between New Lexington and Shawnee with 795 ASCR 26/7. Estimated Cost: \$19.0M (**\$1866.1**)

**Transmission Station Description:**

- Replace the Shawnee 69 kV Moab 1200A switches with 2000 A switches. Estimated Cost: \$0.7M (**\$1866.2**)
- Replace the New Lexington 69 kV line riser towards East Logan. Replace the New Lexington 600 A breaker disconnects for CBs "A" with 2000 A switches. Estimated Cost: \$0.5M (**\$1866.3**)

**Total Estimated Cost:** \$20.2M

**Projected In-Service:** 12/31/2021

**Supplemental Project ID:** S1866.1 – S1866.3

**Project Status:** Scoping

**Model:** N/A

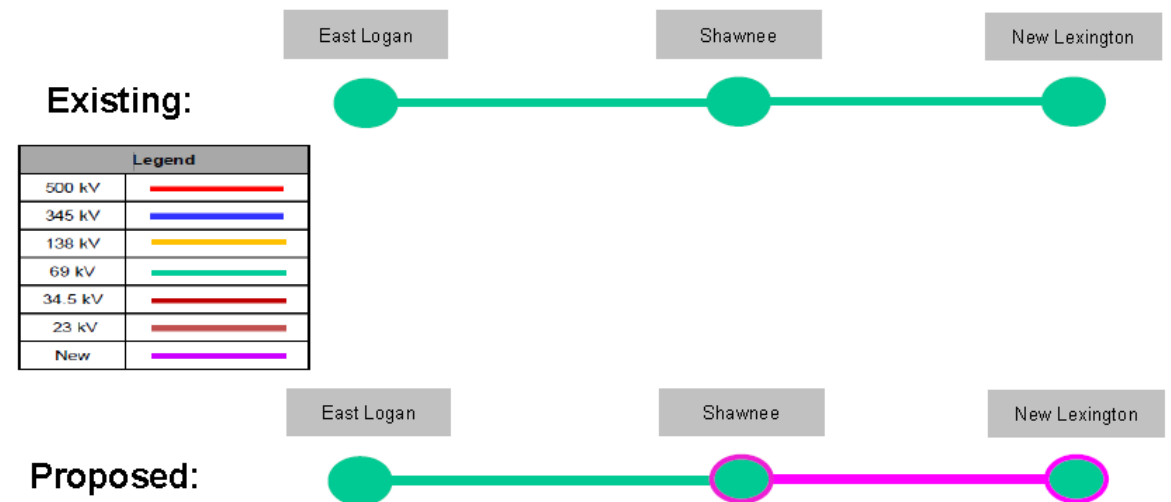

# AEP Transmission Zone M-3 Process Thornville - Lancaster

**Need Number:** AEP-2018-OH031

**Process Stage:** Submission of Supplemental Project for inclusion in the Local Plan 8/29/19

**Previously Presented:**

Needs Meeting 12/21/18

Solution Meeting 2/20/19

**Project Driver:**

Equipment Material/Condition/Performance/Risk

**Specific Assumption Reference:**

AEP Guidelines for Transmission Owner Identified Needs (AEP Assumptions Slide 8)

**Problem Statement:**

- The existing 18.4 mile 69 kV section between Thornville –Lancaster 69 kV line was constructed in 1915 using wood pole structures with several copper conductors (mostly 1/0 Cu).
- There are currently 228 open A conditions on this line. The Baltimore-East Lancaster 69 kV circuit has experienced over 350,000 customer minutes of interruption over the past three years. The majority of outages were due to conductor failures, shielding failures, structure washouts, and insulators failures.



# AEP Transmission Zone M-3 Process Thornville - Lancaster

**Need Number:** AEP-2018-OH031

**Process Stage:** Submission of Supplemental Project for inclusion in the Local Plan 8/29/19

**Selected Solution:**

Rebuild 18.4 miles of the Thornville - Lancaster 69kV line. This line will be rebuilt utilizing 795 ACSR (26/7) at 69 kV standards.

**Estimated Cost:** \$23.66M

**Projected In-Service:** 11/27/19

**Supplemental Project ID:** S1867

**Project Status:** Construction

**Model:** N/A

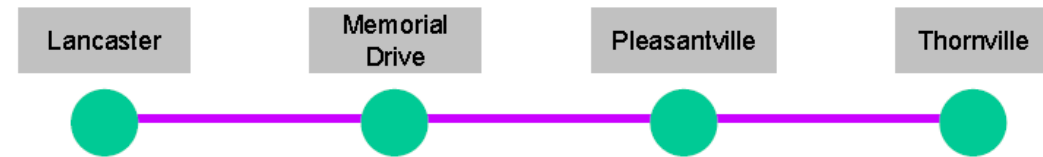

Legend	
500 kV	
345 kV	
138 kV	
69 kV	
34.5 kV	
23 kV	
New	

# AEP Transmission Zone M-3 Process Mabscott

**Need Number:** AEP-2018-AP002

**Process Stage:** Submission of Supplemental Project for inclusion in the Local Plan 10/3/2019

**Previously Presented:**

Needs Meeting 10/26/2018

Solutions Meeting 6/17/2018

**Project Driver:**

Customer Service

**Specific Assumption Reference:**

AEP Connection Requirements for the AEP Transmission System (AEP Assumptions Slide 7)

**Problem Statement:**

APCO Distribution has requested a new distribution station located in Mabscott, West Virginia. Winter projected load 15 MVA.

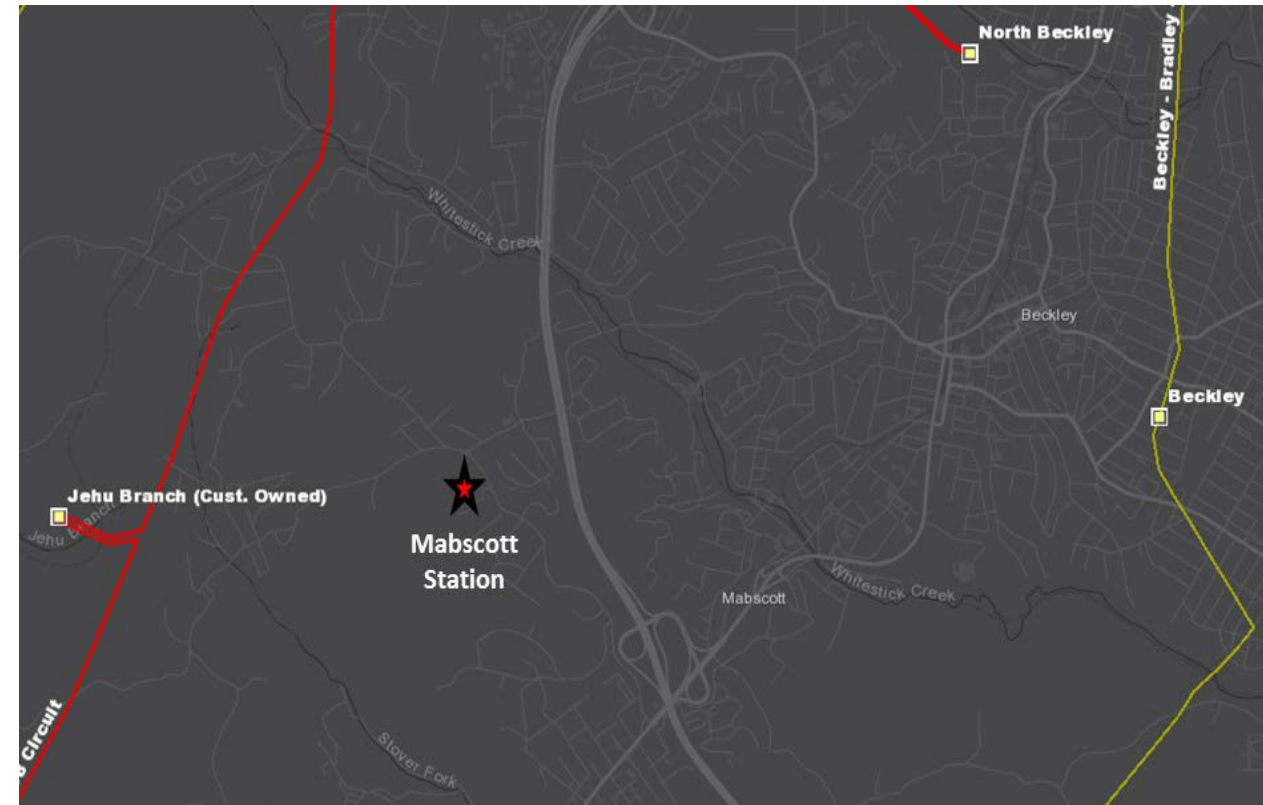

# AEP Transmission Zone M-3 Process Mabscott

**Need Number:** AEP-2018-AP002

**Process Stage:** Submission of Supplemental Project for inclusion in the Local Plan 10/3/2019

**Selected Solution:**

Tap the existing Bradley – Tams Mtn. 138 kV line. Construct a new 138 kV double circuit in/out feed (~1.5 miles) from the Bradley – Tams Mtn. 138 kV Tap, to the new Mabscott Station. (**s1994.1**)

Estimated Transmission Cost: \$6.0M

Install two new 138 kV MOABs at Mabscott Station. Estimated Transmission Cost: \$1.5M (**s1994.2**)

**Total Estimated Cost:** \$7.5M

**Projected In-Service:** 11/1/2020

**Supplemental Project ID:** S1994.1 -.2

**Project Status:** Engineering

**Model:** 2023 RTEP

**Bradley Substation**

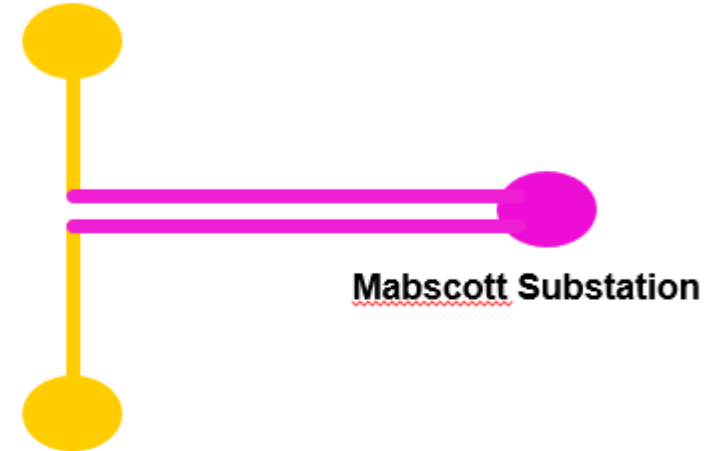

**Tams Mtn. Substation**

Legend	
345 kV	
138 kV	
69 kV	
46 kV	
New	

**Need Number:** AEP-2018-AP003

**Process Stage:** Submission of Supplemental Project for inclusion in the Local Plan 10/3/2019

**Previously Presented:**

Needs Meeting 10/26/2018

Solutions Meeting 4/23/2019

**Project Driver:**

Equipment Condition/Performance/Risk

**Specific Assumption Reference:**

AEP Guidelines for Transmission Owner Identified Needs (AEP Assumptions Slide 8)

**Problem Statement:**

The need to address Mullensville transformer #1 is driven by the short circuit strength breakdown caused by the amount of electrical discharges of high energy has led to rising gas levels in the tank oil and carbonization of the insulating paper. Acetylene is at IEEE Condition 3 and Ethylene is at IEEE Condition 2 per the latest DGA readings in 2018 which contributes to poor dielectric strength. The rising presence of these hot metal gasses can be caused by poor connections, shorted turns, broken winding strands, or inadvertent core grounding from damage to the core ground insulation during through faults events; all of these are indicative of circulating currents in the core resulting in hotspots of the core and surrounding internal components. High energy discharges can be caused by flashovers, tracking or arcing, or short circuits between a number of internal components.

In addition to the 2018 compressor failure on CB A, IPS malfunction records indicate that the compressor motor burnt up in 2008 and failed again in 2009. There are only 13 of these FK-69-1500-3 types on the AEP system, making replacement parts difficult or impossible to obtain. This oil filled breaker has no oil containment and requires O&M costs to maintain the unit's oil that similar SF6 type breakers do not require.

The Ground-Switch MOAB on the high side of the 138/46 kV transformer at Mullensville are obsolete and create an overlap in the zones of protection.

## AEP Transmission Zone M-3 Process Mullensville

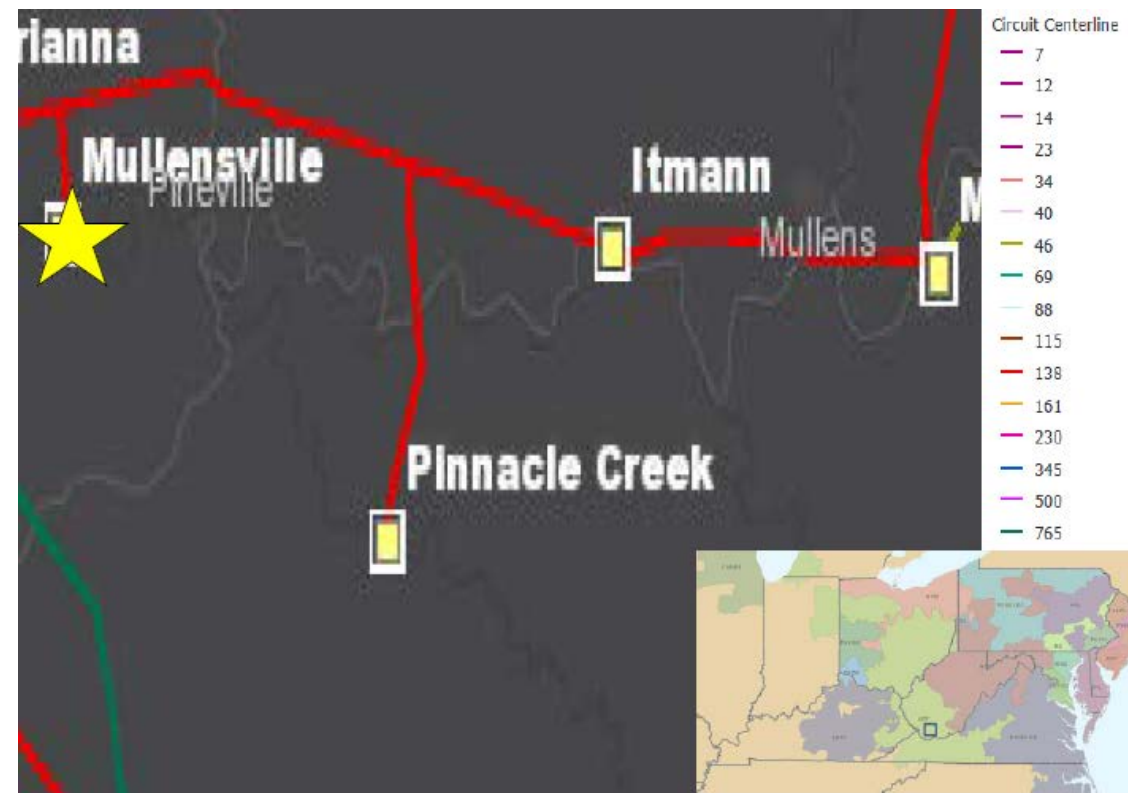



# AEP Transmission Zone M-3 Process Mullensville

**Need Number:** AEP-2018-AP003

**Process Stage:** Submission of Supplemental Project for inclusion in the Local Plan 10/3/2019

**Selected Solution:**

Replace Gr. Sw. MOAB with a new 138 kV circuit switcher.  
Replace existing 138 kV/46 kV 30 MVA XFR #1 with a new 138/46 kV 30 MVA XFR. Replace 46 kV circuit breaker A with a new 46 kV 3000 A 40 kA circuit breaker.

**Estimated Cost:** \$5.4M

**Projected In-Service:** 4/1/2020

**Supplemental Project ID:** S1995

**Project Status:** Scoping

**Model:** N/A

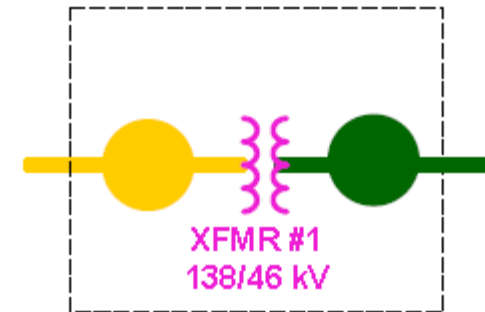

**Mullensville Substation**

Legend	
345 kV	
138 kV	
69 kV	
46 kV	
New	

# AEP Transmission Zone M-3 Process Clendenin

**Need Number:** AEP-2018-AP005

**Process Stage:** Submission of Supplemental Project for inclusion in the Local Plan 10/3/2019

**Previously Presented:**

Needs Meeting 10/26/2018

Solutions Meeting 5/20/2019

**Project Driver:**

Equipment Condition/Performance/Risk

**Specific Assumption Reference:**

AEP Guidelines for Transmission Owner Identified Needs (AEP Assumptions Slide 8)

**Problem Statement:**

On Thursday, June 23, 2016, sustained heavy rain caused severe flooding along the Elk River in West Virginia. The flood waters engulfed much of the town of Clendenin, including Clendenin Station, which sustained significant damage. Clendenin station lies well under the FEMA 100 year flood plain.



# AEP Transmission Zone M-3 Process Clendenin

**Need Number:** AEP-2018-AP005

**Process Stage:** Submission of Supplemental Project for inclusion in the Local Plan 10/3/2019

**Selected Solution:**

Replace the existing Clendenin Station with the new Jarrett Station, approximately 0.2 miles away from Clendenin Station, located outside of the flood plain. Install a new 138/46 kV 90 MVA XFR, with a high side circuit switcher. Install two 138 kV 40 kA CBs and three 46 kV 40 kA CBs. Install a 9.6 MVAR capacitor bank. Re-route the existing 138 kV and 46 kV transmission lines into the new station.

**Total Estimated Transmission Cost:** \$21.3M

**Projected In-Service:** 8/26/2021

**Supplemental Project ID:** S1996

**Project Status:** Scoping

**Model:** N/A

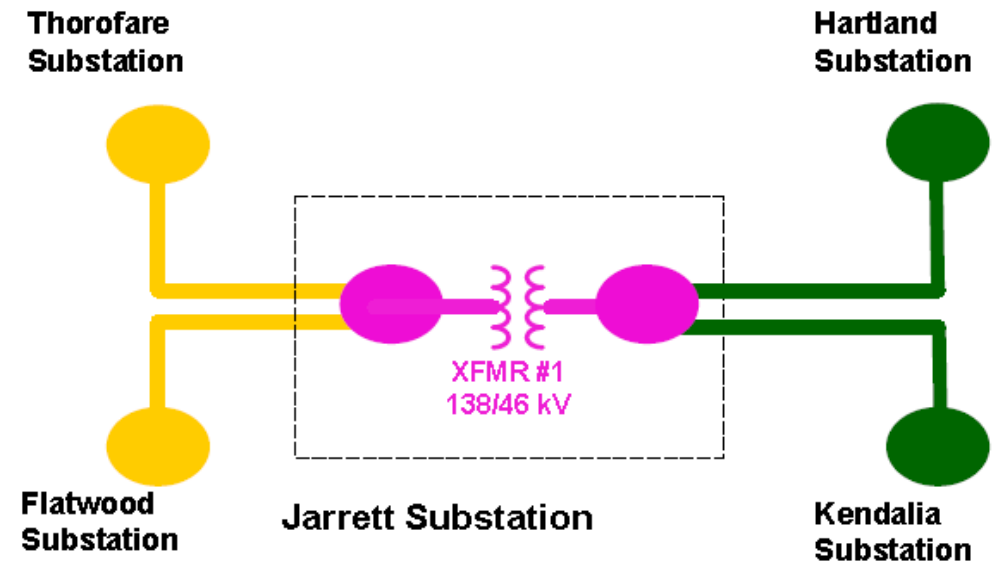

Legend	
345 kV	
138 kV	
69 kV	
46 kV	
New	

# AEP Transmission Zone M-3 Process Huff Creek

**Need Number:** AEP-2018-AP006

**Process Stage:** Submission of Supplemental Project for inclusion in the Local Plan 10/3/2019

**Previously Presented:**

Needs Meeting 10/26/2018

Solutions Meeting 4/23/2019

**Project Driver:**

Equipment Condition/Performance/Risk

**Specific Assumption Reference:**

AEP Guidelines for Transmission Owner Identified Needs (AEP Assumptions Slide 8)

**Problem Statement:**

The need to address Huff Creek transformer #1 is driven by the oil's interfacial tension, which has been consistently below 30 mN/m (the acceptable limit for this voltage class). This is an indication of sludge beginning to form from oil contaminants, which will lead to accelerated aging of the unit; the sludge will impair oil circulation and lead to more frequent overheating. In addition, the moisture content and CO levels have begun a rapid increase over the past four years. CO is now at IEEE Condition 2 and dielectric strength is trending down. The presence of increased CO and moisture levels occurring over the same span of time is indicative of the cellulose breakdown from the insulating paper; this increases the risk of future shorts in the windings due to decreased insulating material.

The need to address Huff Creek ground transformer #2 is driven by Thermal through fault events, mostly in excess of 700°C, have led to, steady increases in gasses including the now IEEE Condition 3 levels of ethylene in PH A, IEEE Condition 2 levels of carbon monoxide in PH A, methane in PH B, and ethylene and methane in PH C. These faults have also generated carbonization of the insulating paper. In addition, all phases have seen sustained and elevated moisture levels which has resulted in low and decreasing dielectric strength.

The 69 kV circuit breaker D is an FK type oil filled circuit breaker with no oil containment. Oil filled breakers have much more maintenance required due to oil handling that their modern, SF6 counterparts do not require. Circuit breaker D is 1 of the 13 remaining FK-69-1500-3 model family remaining on the AEP system. This circuit breaker family is no longer supported by their original vendor and spare parts are scarce to non-existent. In addition, CB D has seen at least 148 faults; based on the maximum fault current levels available for this circuit breaker location, it has likely exceeded the manufactured life expectancy of cumulative fault current, 113 kA.

Huff Creek Substation currently deploys 74 relays, implemented to ensure the adequate protection and operation of the substation. Currently, all 74 (100% of all station relays) are in need of replacement. There are 60 of the electromechanical and 4 of the static type which have significant limitations with regards to spare part availability and fault data collection and retention in addition to a lack of vendor support. The remaining 10 microprocessor relays were commissioned in 1997 and 2007; the warranties are now expired and the firmware is no longer supported by the vendor. There appears to be little available panel space in the existing control house.

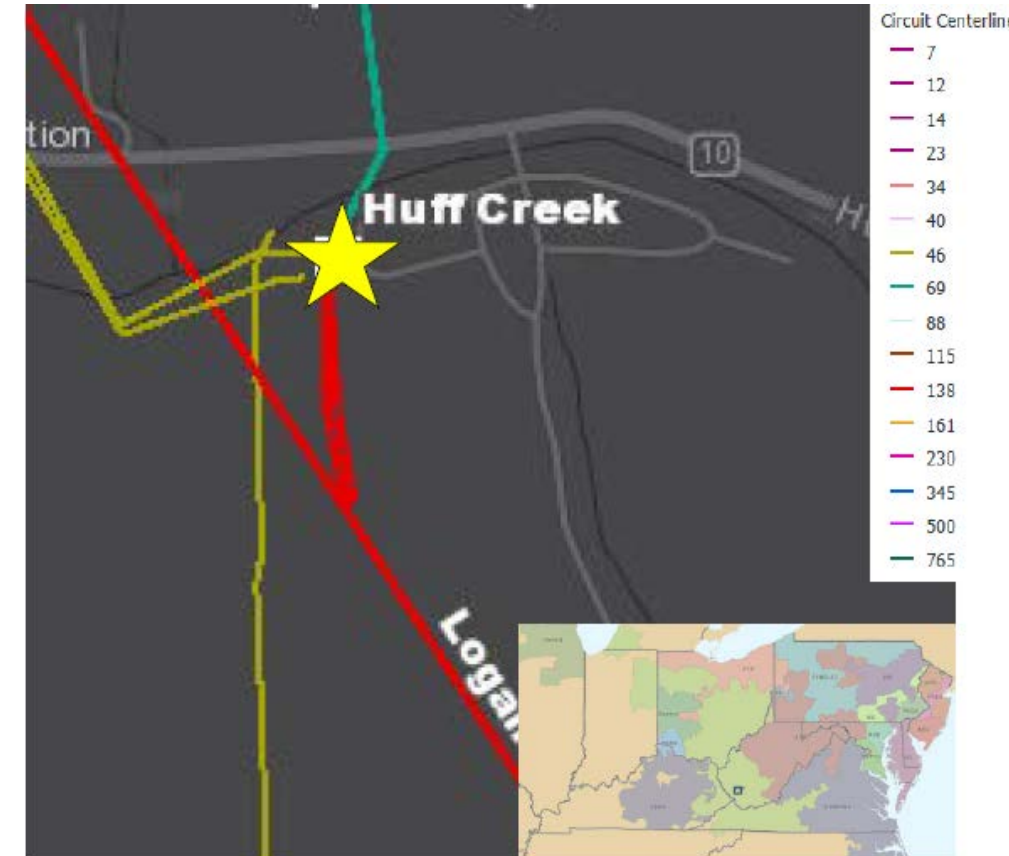

# AEP Transmission Zone M-3 Process Huff Creek

**Need Number:** AEP-2018-AP006

**Process Stage:** Submission of Supplemental Project for inclusion in the Local Plan 10/3/2019

**Selected Solution:**

Replace existing 69 kV CB 'D' with a new 3000 A 40 kA 69 kV CB. Replace the existing 90 MVA 138/69/46 kV transformer #1 with a new 90 MVA 138/69/46 kV transformer. Replace the existing 3000 A GR. TRF Bank with a new 3000 A GR. TRF Bank. Replace the relaying at the station.

**Estimated Cost:** \$6.6M

**Projected In-Service:** 4/1/2020

**Supplemental Project ID:** S1997

**Project Status:** Scoping

**Model:** N/A

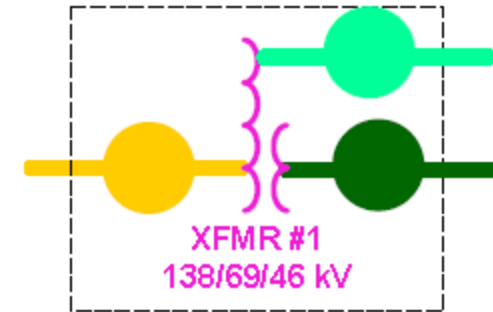

**Huff Creek Substation**

Legend	
345 kV	
138 kV	
69 kV	
46 kV	
New	

# AEP Transmission Zone M-3 Process Huntington Court Capacitor Switchers

**Need Number:** AEP-2018-AP014

**Process Stage:** Submission of Supplemental Project for inclusion in the Local Plan 10/3/2019

**Previously Presented:**

Needs Meeting 1/11/2019

Solutions Meeting 6/17/2019

**Project Driver:**

Equipment Material/Condition/Performance/Risk

**Specific Assumption Reference:**

AEP Guidelines for Transmission Owner Identified Needs (AEP Assumptions Slide 8)

**Problem Statement:**

Huntington Court 138 kV cap switcher BB is a MARK V type which has presented AEP with a large amount of failures and mis-operations. These types of switchers are being replaced and upgraded with the latest AEP cap switcher standard across AEP's system. 69 kV cap switcher AA is an SC-2030 type that has no gas monitor and sister units have experienced numerous gas and interrupter failures.

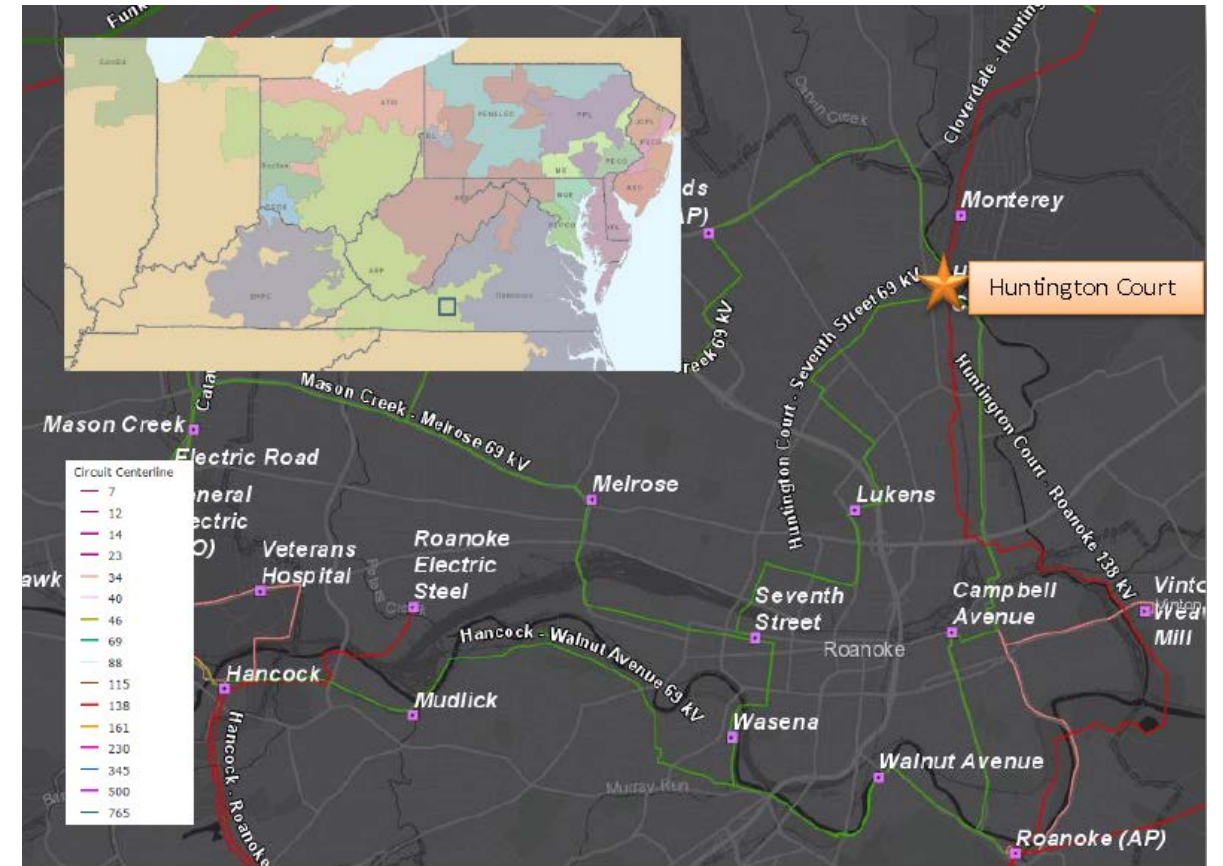

## AEP Transmission Zone M-3 Process Huntington Court Capacitor Switchers

**Need Number:** AEP-2018-AP014

**Process Stage:** Submission of Supplemental Project for inclusion in the Local Plan 10/3/2019

**Selected Solution:**

Replace existing 138 kV capacitor bank switcher BB and 69 kV capacitor bank switcher AA with capacitor bank breakers.

**Estimated Cost:** \$0 (All Distribution Cost)

**Projected In-Service:** 10/31/2020

**Supplemental Project ID:** S1998

**Project Status:** Engineering

**Model:** N/A

No bubble diagram required

# AEP Transmission Zone M-3 Process Matt Funk Breaker Replacements

**Need Number:** AEP-2018-AP015

**Process Stage:** Submission of Supplemental Project for inclusion in the Local Plan 10/3/2019

**Previously Presented:**

Needs Meeting 1/11/2019

Solutions Meeting 6/17/2019

**Project Driver:**

Equipment Material/Condition/Performance/Risk

**Specific Assumption Reference:**

AEP Guidelines for Transmission Owner Identified Needs (AEP Assumptions Slide 8)

**Problem Statement:**

138 kV circuit breakers H1, K, K1, K2 are PK air blast breakers manufactured in 1968. Air blast breakers are being replaced across the AEP system due to their potential for catastrophic and violent failures. Sharp pieces of porcelain from their bushings are typically expelled from the breakers and can be a potential safety hazard to field personnel. Other factors driving the replacement are age and scarce availability of spare parts. In addition, breakers H1, K, K1, K2 have experienced 55, 31, 32, and 26 fault operations, respectively.

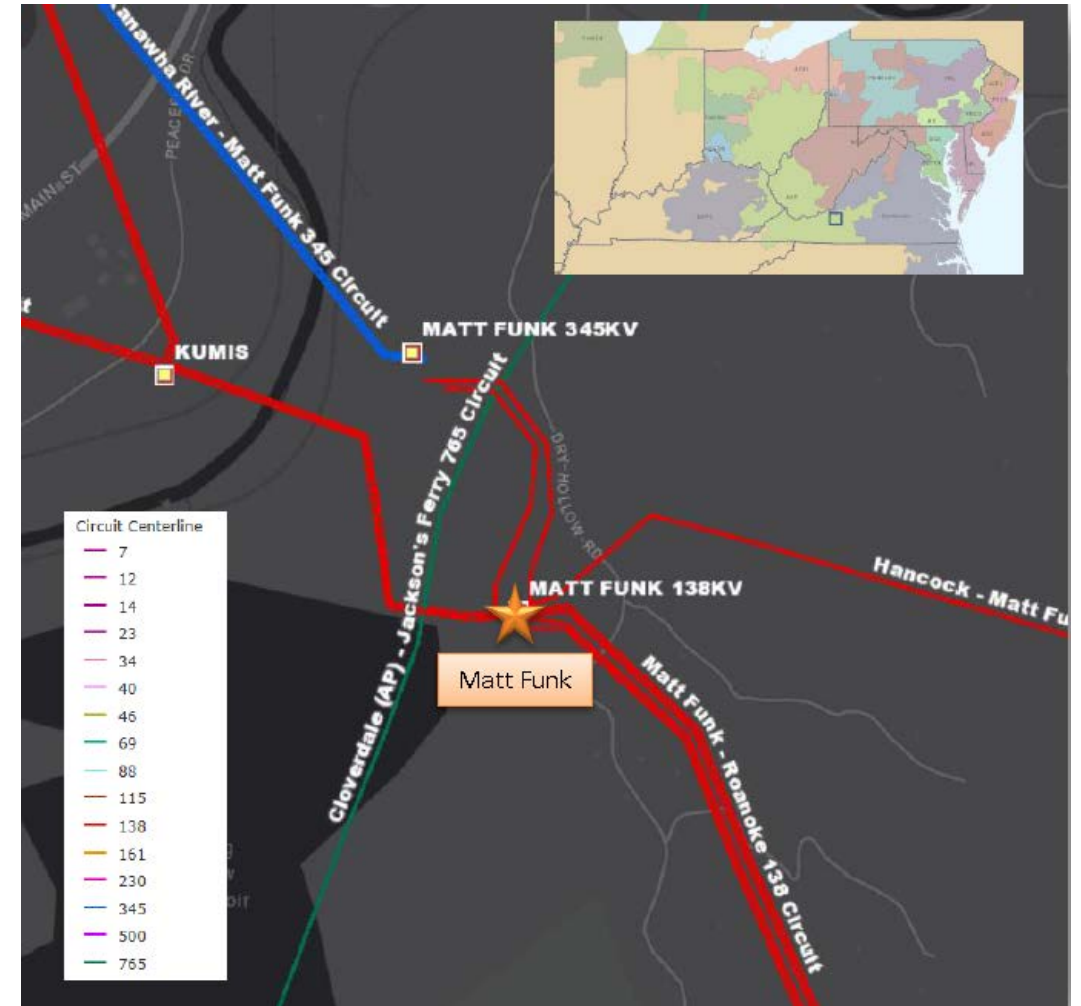



# AEP Transmission Zone M-3 Process Matt Funk Breaker Replacements

**Need Number:** AEP-2018-AP015

**Process Stage:** Submission of Supplemental Project for inclusion in the Local Plan 10/3/2019

**Selected Solution:**

Replace existing 138 kV circuit breakers H1, K, K1, K2 and associated disconnect switches at Matt Funk Station with four new 138 kV, 3000 A, 63 kA circuit breakers and 3000 A switches.

**Estimated Cost:** \$1.7M

**Projected In-Service:** 10/31/2020

**Supplemental Project ID:** S1999

**Project Status:** Engineering

**Model:** N/A

No bubble diagram required

# AEP Transmission Zone M-3 Process Clifford-Scottsville

**Need Number:** AEP-2019-AP004

**Process Stage:** Submission of Supplemental Project for inclusion in the Local Plan 10/3/2019

**Previously Presented:**

Needs Meeting 2/20/2019

Solutions Meeting 5/20/2019

**Project Driver:**

Equipment Material/Condition/Performance/Risk

**Specific Assumption Reference:**

AEP Guidelines for Transmission Owner Identified Needs (AEP Assumptions Slide 8)

**Problem Statement:**

The Amherst-Clifford 69 kV circuit (13.9 mi.) consists primarily of 1960 wood pole structures with 4/0 ACSR overhead conductor and currently has 26 open conditions including rot top, woodpecker damage, split poles, broken insulators and damaged shield wire. Over the 2015-2018 time frame there were 5 momentary outages which occurred during lightning and wind events due to the lack of shield wire on half of the circuit, exposing it to a higher probability of forced momentary and permanent lightning induced outages.

The Clifford-Scottsville 46 kV circuit (45.5 mi.) consists primarily of 1926 wood pole structures with 4/0 ACSR overhead conductor and currently has 93 open conditions including rot top, rot heart and woodpecker/insect damage. Over the last recorded 3 year period, 6 permanent outages were observed. Also, only 16% of the line has shielding, mainly on the tap sections.

Riverville station serves a large industrial customer (Grief Brothers Corporation) consisting of approximately 45 MW from a radial 138 kV line served from Boxwood S.S. located between Clifford and Reusens. This radial line is approximately 9.2 miles long, leaving a large amount of load exposed to a variety of single contingency events.

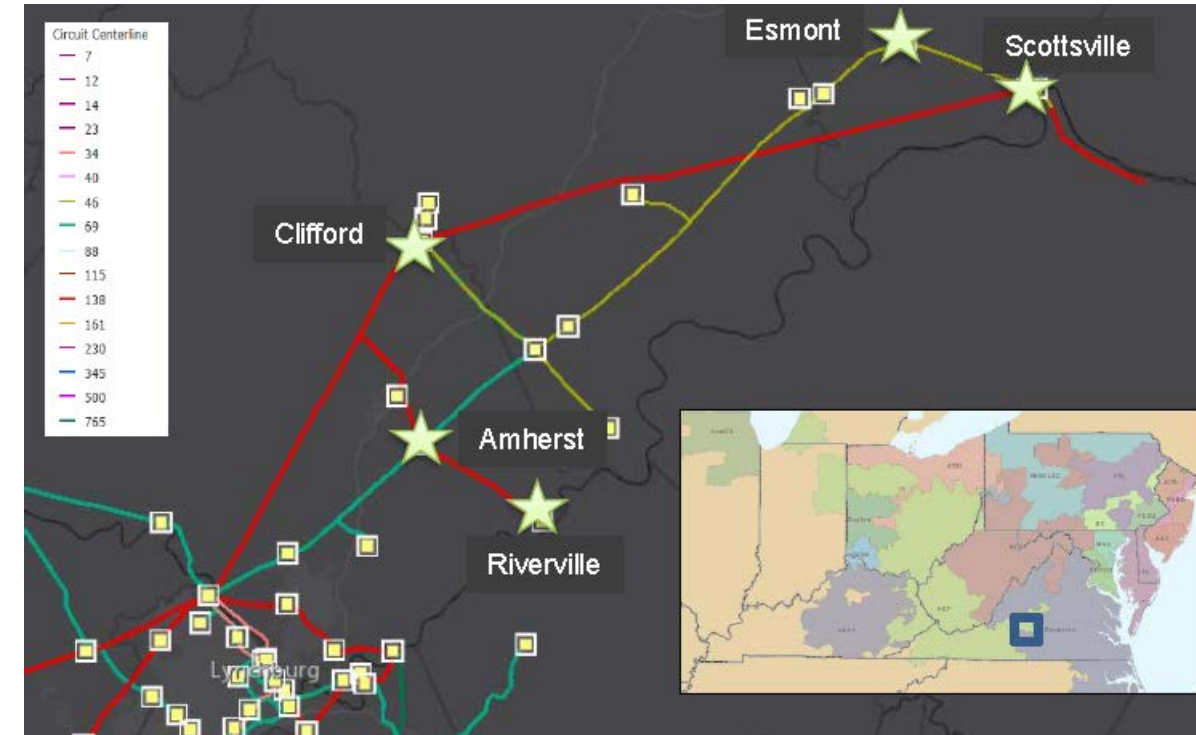



AEP Transmission Zone M-3 Process  
Scottsville-Clifford-Amherst

**Need Number:** AEP-2019-AP004, AEP-2019-AP009

**Process Stage:** Submission of Supplemental Project for inclusion in the Local Plan 10/3/2019

**Selected Solution:**

Rebuild Monroe-Amherst 69 kV line section (~7.9 mi.)

**S2000.1 Estimated Cost:** \$22.0 M

Rebuild Esmont-Scottsville 46 kV line section (~6.0 mi.)

**S2000.2 Estimated Cost:** \$17.0 M

**Ancillary Benefits:** Supplemental solution is part of a holistic plan to address baseline and supplemental needs in the area.

**Estimated Cost:** \$39 M

**Projected In-Service:** 10/1/2022

**Supplemental Project ID:** S2000.1 -.2

**Project Status:** Scoping

**Model:** N/A

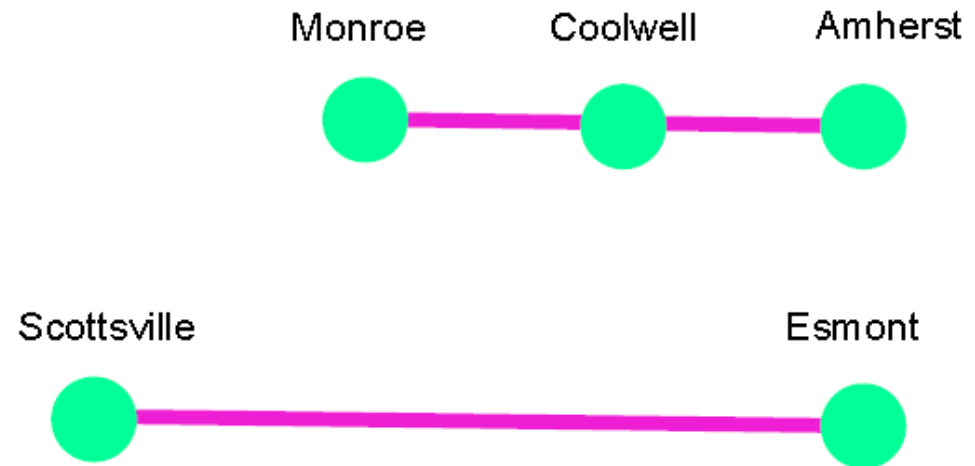

Legend	
345 kV	
138 kV	
69 kV	
46 kV	
New	



# AEP Transmission Zone M-3 Process Mound Street

**Need Number:** AEP-2018-OH013

**Process Stage:** Submission of Supplemental Project for inclusion in the Local Plan 10/3/2019

**Selected Solution:**

At Mound Street station, replace CB-101 with a new 138 kV 3000 A, 40 kA CB. Install new risers, rated at 3000 A. Upgrade 138 kV relaying.

**Estimated Cost:** \$1.1M

**Projected In-Service:** 12/30/2019

**Supplemental Project ID:** S2001

**Project Status:** Scoping

**Model:** N/A

**Existing:**

Mound Street



Legend	
500 kV	
345 kV	
138 kV	
69 kV	
34.5 kV	
23 kV	
New	

**Proposed:**

Mound Street



# AEP Transmission Zone M-3 Process Bixby Transformer

**Need Number:** AEP-2018-OH028

**Process Stage:** Submission of Supplemental Project for inclusion in the Local Plan 10/3/2019

**Previously Presented:**

Needs Meeting 1/11/2019

Solutions Meeting 6/17/2019

**Project Driver:**

Equipment Material/Condition/Performance/Risk

**Specific Assumption Reference:**

AEP Guidelines for Transmission Owner Identified Needs (AEP Assumptions Slide 8)

**Problem Statement:**

The 345/138 kV, 675 MVA transformer #1 failed and caught fire at Bixby station. The MOAB switch and risers cannot be repaired. A replacement is needed to support the load in the area.

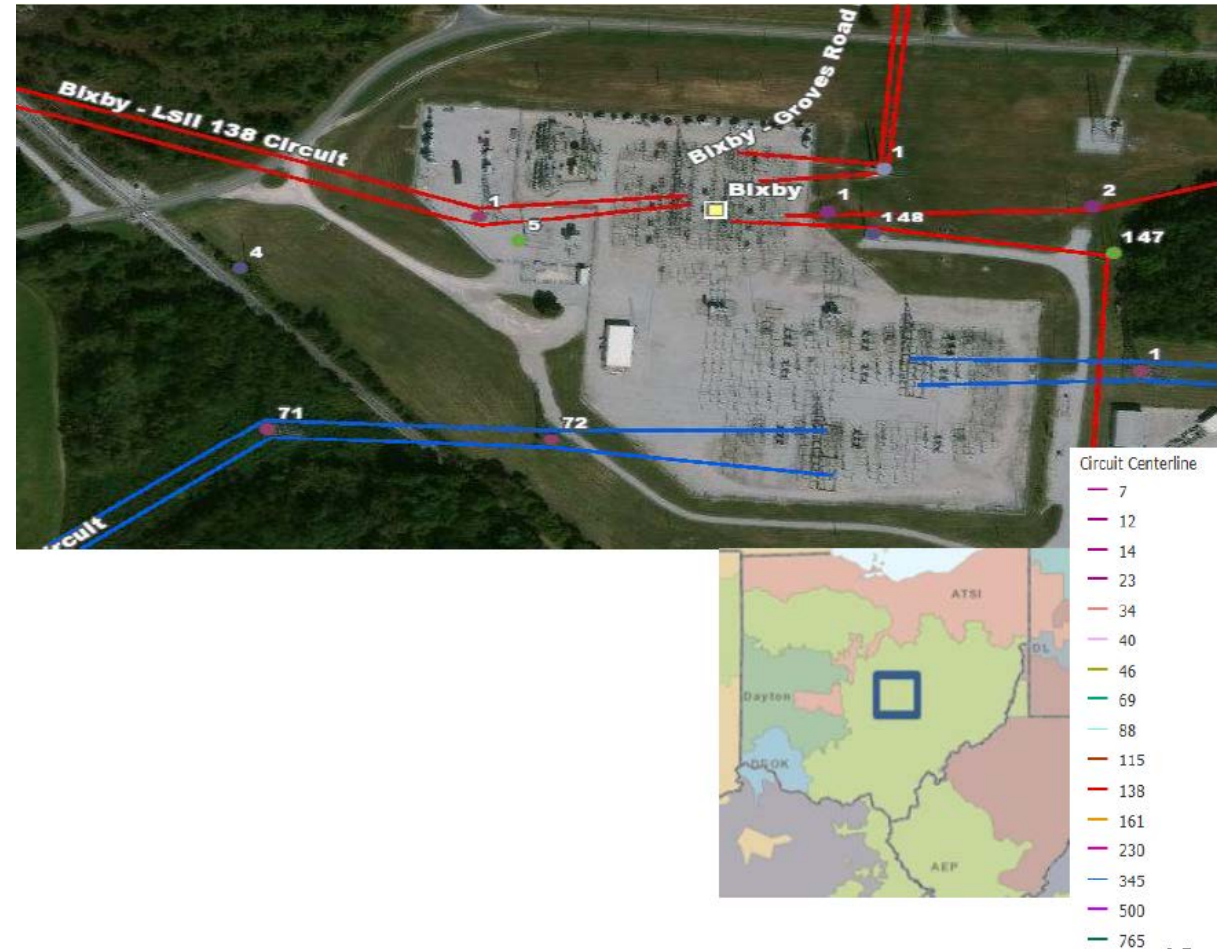

# AEP Transmission Zone M-3 Process Bixby Transformer

**Need Number:** AEP-2018-OH028

**Process Stage:** Submission of Supplemental Project for inclusion in the Local Plan 10/3/2019

**Selected Solution:**

At Bixby station, replace the failed transformer #1 with a 675 MVA, 345/138 kV transformer. Replace the damaged switches with 3000 A switches.

**Estimated Cost:** \$4.5M

**Projected In-Service:** 6/30/2019







**Supplemental Project ID:** S2002

**Project Status:** Engineering

**Model:** N/A

**Existing:**



Legend	
500 kV	
345 kV	
138 kV	
69 kV	
34.5 kV	
23 kV	
New	

**Proposed:**





Need Number: AEP-2019-OH001

Process Stage: Submission of Supplemental Project for inclusion in the Local Plan 10/3/2019

**Previously Presented:**

Needs Meeting 2/20/2019

Solutions Meeting 7/24/2019

**Project Driver:**

Equipment Material/ Condition/Performance/Risk & Operational Flexibility

**Specific Assumption Reference:**

AEP Guidelines for Transmission Owner Identified Needs

**Problem Statement:**

- The Glencoe-Somerton 69 kV circuit is 22.5 miles in length and has numerous condition issues. Within the last 5 years, it has experienced 18 momentary outages (3.6 per year) and 7 permanent (sustained) outages (1.4 per year). The average outage duration has been 13.7 hours. AEP and South Central Power Co-op customers served from this circuit suffered nearly 3.5 million minutes of customer interruption (CMI) during the 2015-2018 timeframe.
- The circuit currently has 148 open conditions (43 structural, 23 on conductor, 5 for shielding/grounding, 24 for hardware, and 53 for forestry/ROW). The majority of the wood poles were installed in 1953 and 1970 (84% of circuit length). The conductor was also primarily installed in 1953 (219 kcmil ACSR) and 1970 (336 kcmil ACSR). The majority of the outage causes have been attributed to T-Line condition issues.
- The two 69 kV delivery points for South Central Power Co-op's Beallsville and Pipe Creek stations are connected via hard taps (no sectionalizing switches present). This requires an outage to the customer whenever maintenance or emergency repairs must be done on either side of the customer tap.

## AEP Transmission Zone M-3 Process Glencoe-Somerton 69 kV Upgrade

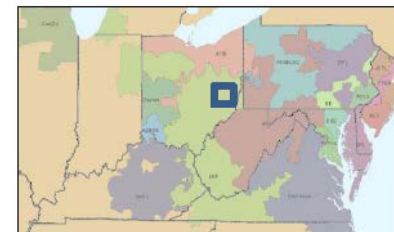

# AEP Transmission Zone M-3 Process Glencoe-Somerton 69 kV Upgrade

**Need Number:** AEP-2019-OH001

**Process Stage:** Submission of Supplemental Project for inclusion in the Local Plan 10/3/2019

**Selected Solution:**

Rebuild the Glencoe-Somerton 69 kV circuit (22 miles) with single-circuit 795 ACSR conductor. **S2003.1**

**Estimated Cost: \$59.8 M**

Replace the Pipe Creek hard tap with a 1200 A-rated 3-way switch (Jacobsburg Switch). **S2003.2**

**Estimated Cost: \$0.7 M**

Replace the Beallsville hard tap with a 1200 A-rated 3-way switch (Beallsville Switch). **S2003.3**

**Estimated Cost: \$1.0 M**

**Total Estimated Cost: \$61.5 M**

**Projected In-Service: 6/1/2022**

**Supplemental Project ID: S2003.1 -.3**

**Project Status:** Scoping

**Model:** N/A

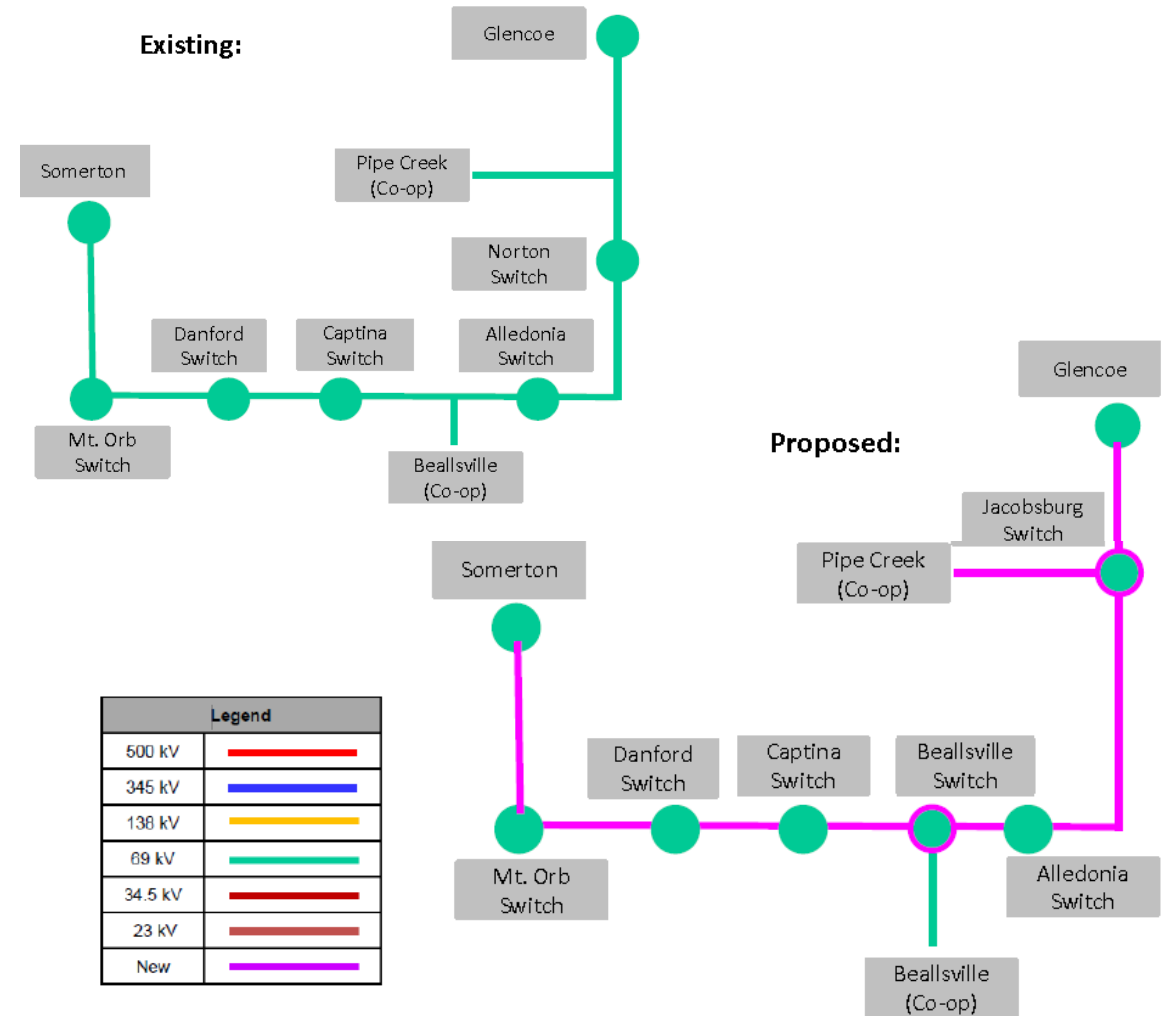

# AEP Transmission Zone M-3 Process Blackhawk – Dillonvale

**Need Number:** AEP-2019-OH002

**Process Stage:** Submission of Supplemental Project for inclusion in the Local Plan 10/3/2019

**Previously Presented:**

Needs Meeting 2/20/2019

Solutions Meeting 5/20/2019

**Project Driver:**

Equipment/Material/Condition/Performance/Risk

**Specific Assumption Reference:**

AEP Guidelines for Transmission Owner Identified Needs (AEP Assumptions Slide 8)

**Problem Statement:**

The Blackhawk-Dillonvale-Sparrow 69 kV line was originally constructed in 1918 and approximately 30% of the wood structures are still from 1918. More than half of the structures are of pre-1980 vintage and are affected by heavy rot and woodpecker & insect damage through the years. 70% of the conductor is from 1926 or prior and is starting to show signs of tensile-related failures. There are 180 open A conditions on this line. Sections of the Blackhawk-Parlett line (Blackhawk Extension, Raider Extensions and Rexford Extension) have been recently rebuilt to 138 kV standards. (Shown in Red)

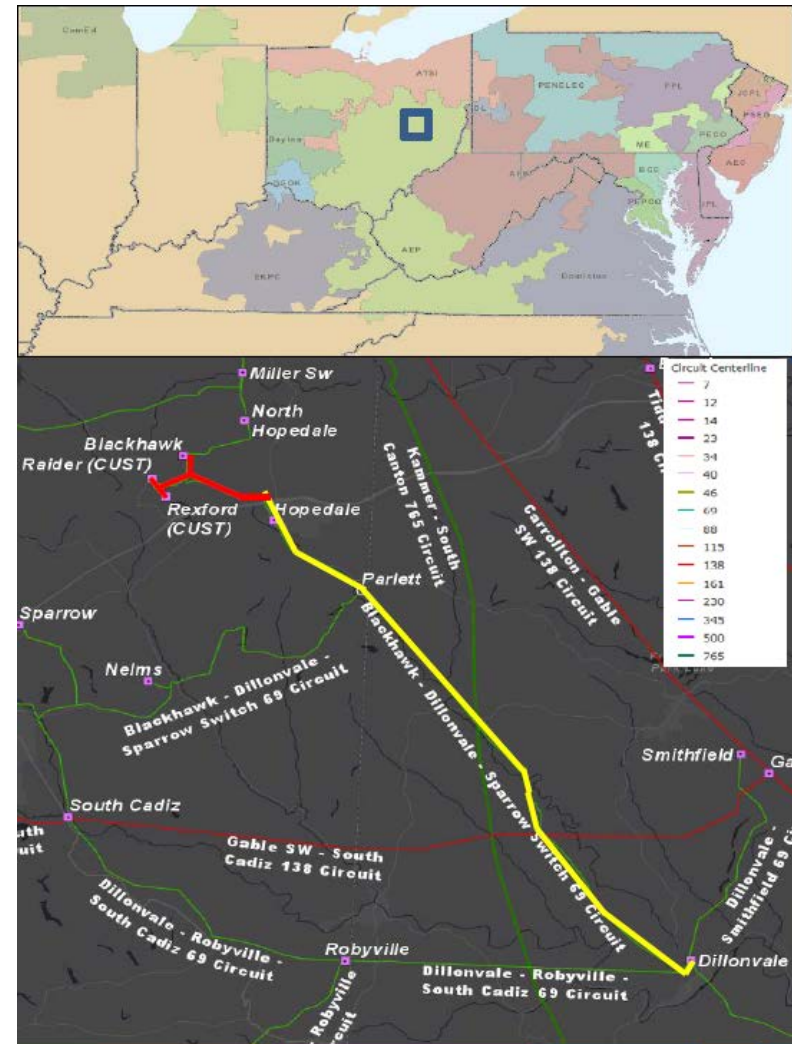

# AEP Transmission Zone M-3 Process Blackhawk – Dillonvale

**Need Number:** AEP-2019-OH002

**Process Stage:** Submission of Supplemental Project for inclusion in the Local Plan 10/3/2019

**Selected Solution:**

Rebuild the 9.3 mile, Dillonvale – Parlett 69 kV line, using 795 ACSR conductors. **S2004.1 Estimated Cost: \$31.8M**

Rebuild 2.5 mile section of 69 kV line from Parlett to Blackhawk, using 795 ACSR conductors. **S2004.2 Estimated Cost: \$8.0M**

Rebuild ~2 mile section of the Blackhawk-N. Hopedale-Miller Sw 69 kV circuit, using 795 ACSR conductors. **S2004.3 Estimated Cost: \$6.8M**

Retire the 0.12 mile radial line from Rose Valley Sw. **S2004.4 Estimated Cost: \$0.1M**

At Hopedale 69 kV station, install new H-Frame for T-line termination and 69kV line disconnect GOABs (40 kA, 1200A). **S2004.5 Estimated Cost: \$0.5M**

At North Hopedale switch, replace the switch with a new phase-over-phase switch (40 kA, 1200A) **S2004.6 Estimated Cost: \$0.5M**

Retire the switch at Rose Valley. **S2004.7 Estimated Cost: \$0.2M**

**Total Estimated Cost: \$47.9M**

**Projected In-Service:** 11/15/2022

**Supplemental Project ID:** S2004.1 -.7

**Project Status:** Scoping

**Model:** N/A

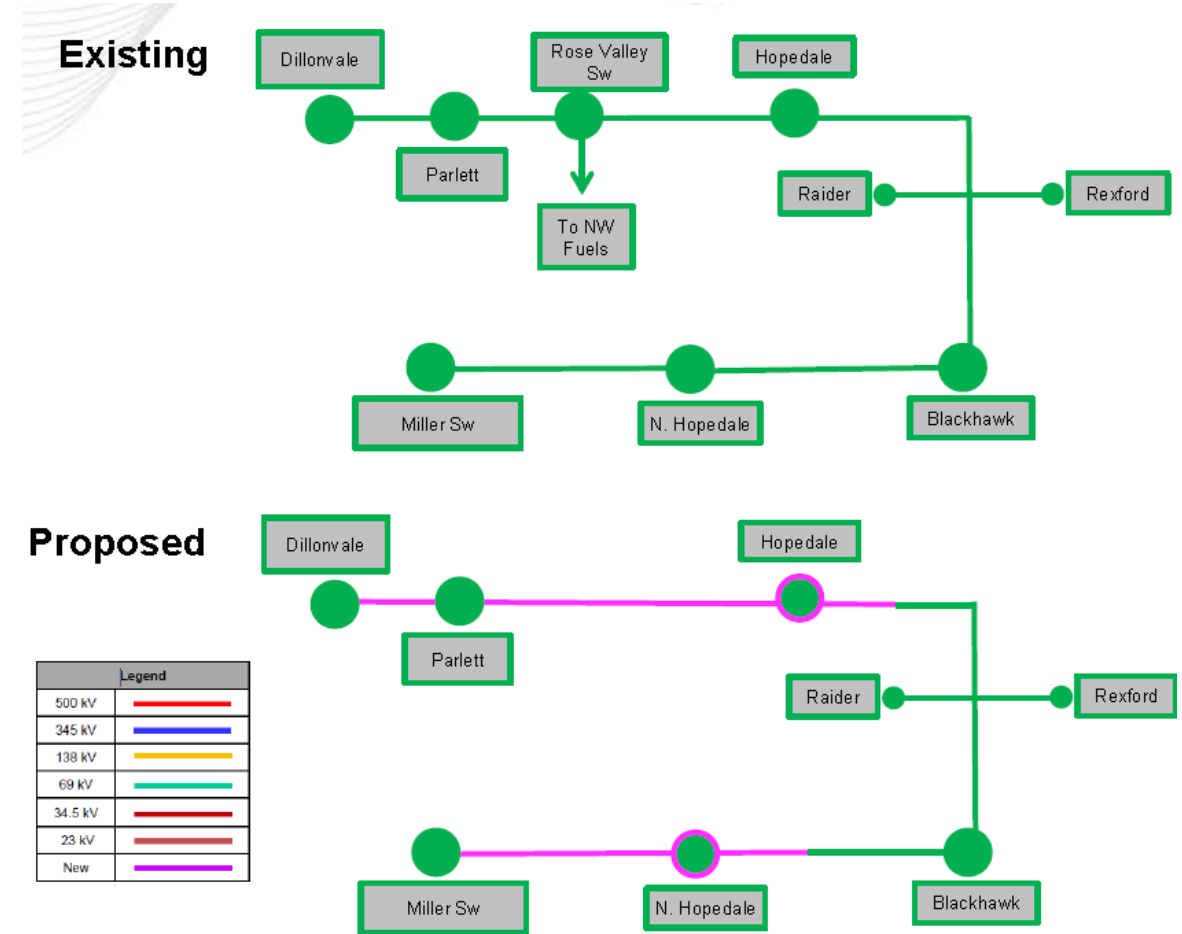

# AEP Transmission Zone M-3 Process Trump Switch

**Need Number:** AEP-2019-OH003

**Process Stage:** Submission of Supplemental Project for inclusion in the Local Plan 10/3/2019

**Previously Presented:**

Needs Meeting 2/20/2019

Solutions Meeting 5/20/2019

**Project Driver:**

Customer Request

**Specific Assumption Reference:**

AEP Guidelines for Transmission Owner Identified Needs (AEP Assumptions Slide 8)

**Problem Statement:**

Customer wants to install a 2nd 69/12 kV transformer to support increase in load. Customer indicated January 1, 2019 is the only outage window they have for this upgrade.

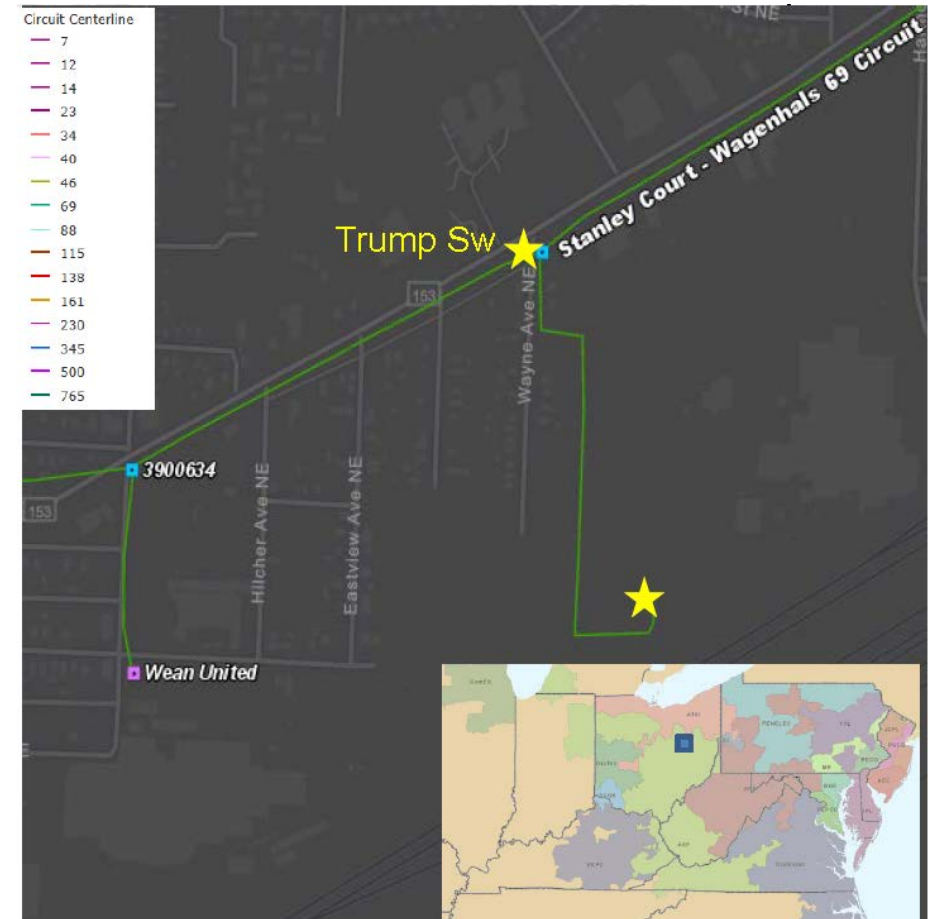

# AEP Transmission Zone M-3 Process Trump Switch

**Need Number:** AEP-2019-OH003

**Process Stage:** Submission of Supplemental Project for inclusion in the Local Plan 10/3/2019

**Selected Solution:**

Trump Switch-Freshmark Line Work:

AEP will provide a second 69 kV feed to the customer by tapping the existing Trump Switch – Freshmark line and installing two pole structures. The customer will build a new 69 kV line from AEP's structures to the new customer owned transformer.

**Estimated Cost:** \$0.2M

**Projected In-Service:** 1/1/2019

**Supplemental Project ID:** S2005

**Project Status:** In-Service

**Model:** 2024 RTEP

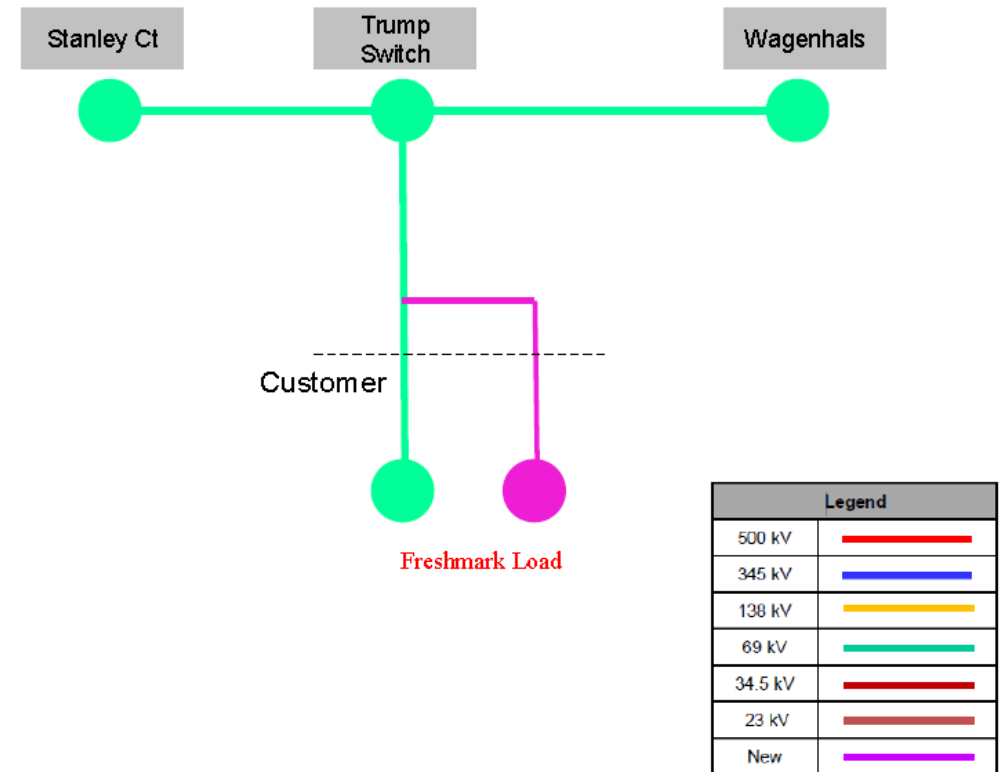

# AEP Transmission Zone M-3 Process Gavin-Meigs

**Need Number:** AEP-2019-OH008

**Process Stage:** Submission of Supplemental Project for inclusion in the Local Plan 10/3/2019

**Previously Presented:**

Needs Meeting 03/25/2019

Solutions Meeting 05/20/2019

**Project Driver:**

Equipment Material/Condition/Performance/Risk

**Specific Assumption Reference:**

AEP Guidelines for Transmission Owner Identified Needs **Problem Statement:**

Meigs 69 kV CB "1" is a vintage (1954) oil-filled circuit breaker. Oil breakers are difficult to maintain due to oil handling requirements and risk of oil spills during maintenance and failures. This model (G.E. FK-439-69-1000-4) is also recommended for replacement due to reliability issues, lack of vendor support, and lack of spare part availability. In addition, this CB has exceeded the manufacturers recommended number of fault operations: CB 1 (20).

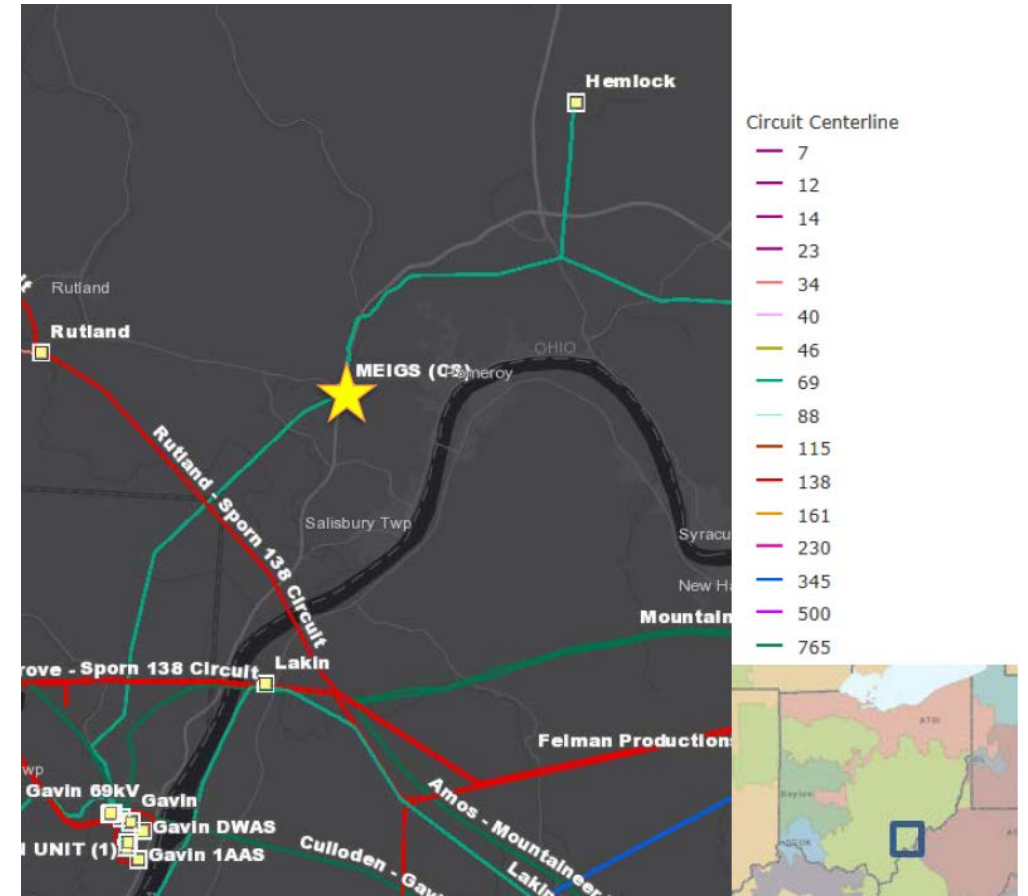

# AEP Transmission Zone M-3 Process Gavin-Meigs

**Need Number:** AEP-2019-OH008

**Process Stage:** Submission of Supplemental Project for inclusion in the Local Plan 10/3/2019

**Selected Solution:**

Meigs Station:

Replace CB-1 with a new 69 kV 2000A/40 kA breaker.

**Estimated Cost:** \$0.33M

**Projected In-Service:** 06/30/2022

**Supplemental Project ID:** S2006

**Project Status:** Scoping

**Model:** N/A



**Existing:**

Legend	
500 kV	
345 kV	
138 kV	
69 kV	
34.5 kV	
23 kV	
New	

**Proposed:**

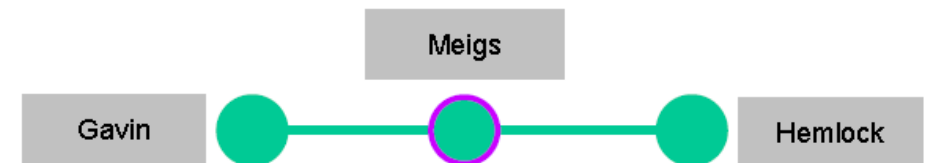



# AEP Transmission Zone M-3 Process Parlett – South Cadiz Rebuild

**Need Number:** AEP-2019-OH009

**Process Stage:** Submission of Supplemental Project for inclusion in the Local Plan 10/3/2019

**Previously Presented:**

Needs Meeting 3/25/2019

Solutions Meeting 6/17/2019

**Project Driver:**

Customer Service, Equipment Condition, and Operational Flexibility

**Specific Assumption Reference:**

AEP Guidelines for Owner Identified Needs

**Problem Statement:**

- East Cadiz Switch (1950's) serves Cadiz station on a mile long radial line, which is in a remote part of our system. In addition, this switch is sitting in an area prone to flooding.
- The Parlett-East Cadiz 69kV line, approximately 8 miles long, is comprised of deteriorated 1929 vintage wood structures and still has original 1/0 Cu and 4/0 ACSR conductor on it.
- The South Cadiz-East Cadiz 69kV line, approximately 2 miles long, is comprised of deteriorated 1954 vintage wood structures with the original 4/0 ACSR conductor on it.
- The Parlett-South Cadiz 69kV line has 190 open conditions.
- The Blackhawk – Miller Switch 69 kV line section, approximately 2.5 miles long, has some of the original 1918 conductor still on it (1/0 Cu). More than half of the wood pole structures on this sections are of pre-1980 vintage and are affected by heavy rot, woodpecker,



# AEP Transmission Zone M-3 Process Parlett – South Cadiz Rebuild

**Need Number:** AEP-2019-OH009

**Process Stage:** Submission of Supplemental Project for inclusion in the Local Plan 10/3/2019

**Selected Solution:**

Rebuild 9.65 miles of 69 kV line as single circuit using 795 ACSR conductor, energized at 69 kV. Install ADSS. **S2007.1 Cost: \$39.42M**

Retire 0.41 miles radial, de-energized 69 kV line that is routed west from Unionvale Switch. **S2007.2 Cost: \$0.76M**

Retire Unionvale Switch **S2007.3 Cost: \$0.13M**

Replace and relocate East Cadiz Switch with a three way POP Switch (2,000 A) with MOAB's on each side. **S2007.4 Cost: \$0.72M**

Remote relaying at South Cadiz, Parlett, & Sparrow. **S2007.5 Cost: \$0.5M**

**Total Estimated Cost:** \$41.53M

**Projected In-Service:** 12/01/2020

**Supplemental Project ID:** S2007.1 - .5

**Project Status:** Engineering

**Model:** 2024 RTEP

**Existing:**

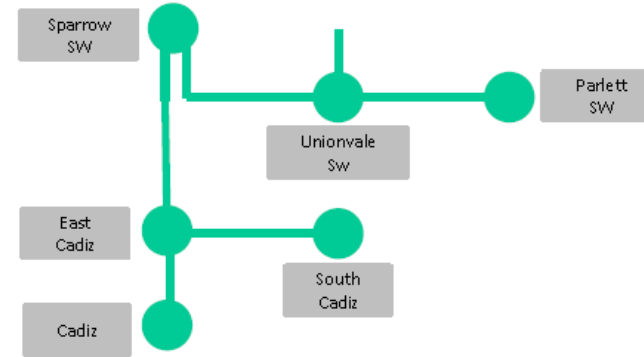

**Proposed:**

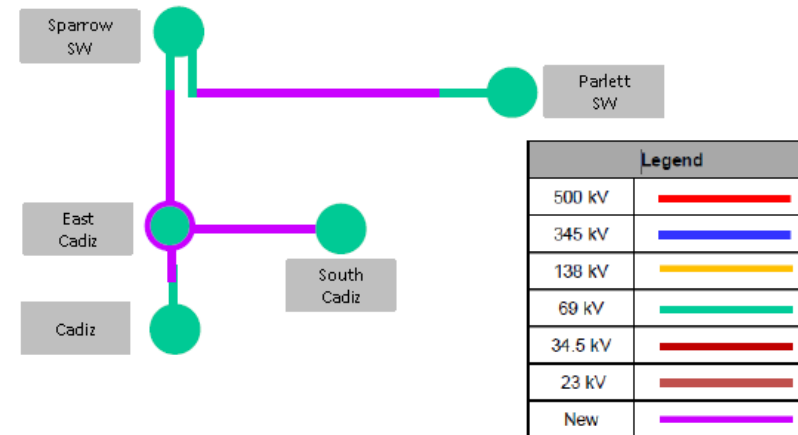

# AEP Transmission Zone M-3 Process Don Marquis – Stuart

**Need Number:** AEP-2019-OH010

**Process Stage:** Submission of Supplemental Project for inclusion in the Local Plan 10/3/2019

**Previously Presented:**

Needs Meeting 4/11/2019

Solutions Meeting 6/13/2019

**Project Driver:**

Operational performance

**Specific Assumption Reference:**

AEP Guidelines for Transmission Owner Identified Needs

**Problem Statement:**

- Killen Plant is retiring and the 345 kV taps to this plant will be de-energized. AEP has taken ownership of the Don Marquis-Stuart 345 kV line and needs to bypass the Killen taps to complete the Don Marquis-Stuart 345 kV circuit. AEP will take control of this circuit apply our rating methodology to it.

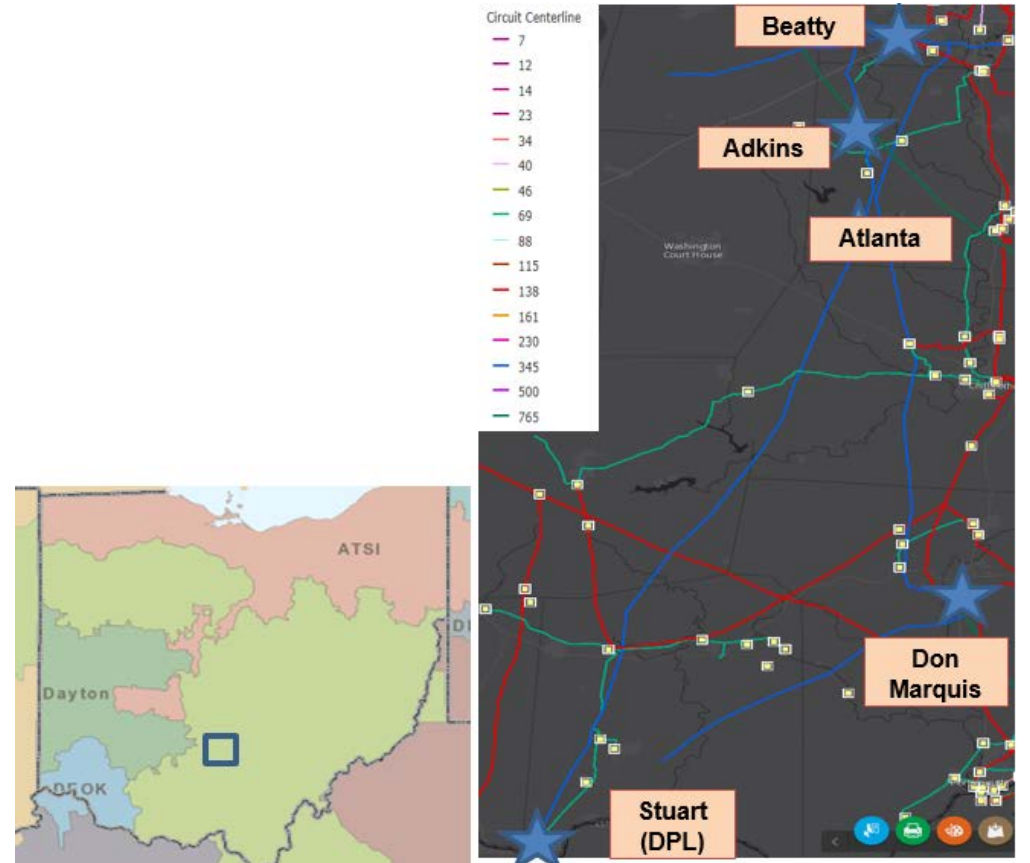

# AEP Transmission Zone M-3 Process Don Marquis – Stuart

**Need Number:** AEP-2019-OH010

**Process Stage:** Submission of Supplemental Project for inclusion in the Local Plan 10/3/2019

**Selected Solution:**

Re-energize the Don Marquis-Stuart 345 kV line between the existing taps. **S2008.1**

**Estimated Cost:** \$0.6M

At Don Marquis station, upgrade relaying and retire intercompany metering on Stuart 345kV line. **S2008.2**

**Estimated Cost:** \$0.4M

**Total Estimated Cost:** \$1.0M

**Projected In-Service:** 10/01/2020

**Supplemental Project ID:** S2008.1 - .2

**Project Status:** Scoping

**Model:** 10/01/2020

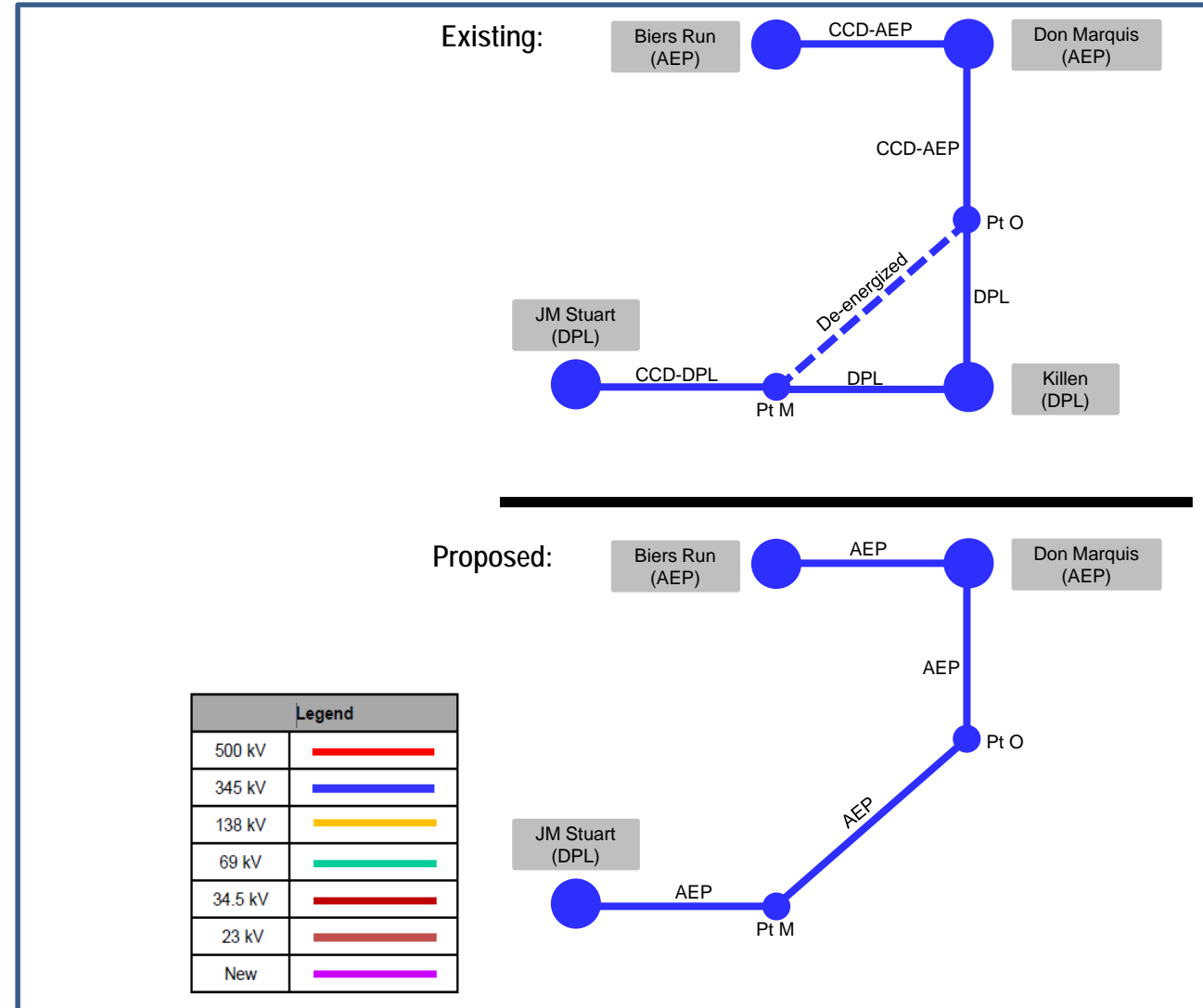

# AEP Transmission Zone M-3 Process Carrothers

**Need Number:** AEP-2019-OH021

**Process Stage:** Submission of Supplemental Project for inclusion in the Local Plan 10/3/2019

**Previously Presented:**

Needs Meeting 4/23/2019

Solutions Meeting 6/17/2019

**Project Driver:**

Operational Flexibility and Efficiency

**Specific Assumption Reference:**

AEP Guidelines for Owner Identified Needs (AEP Assumptions slide 8)

**Problem Statement:**

The Carrothers 69 kV Station has three dissimilar zones of protection (Bus, Transformer, and Line). Dissimilar zones of protection can cause mis-operations and over tripping.

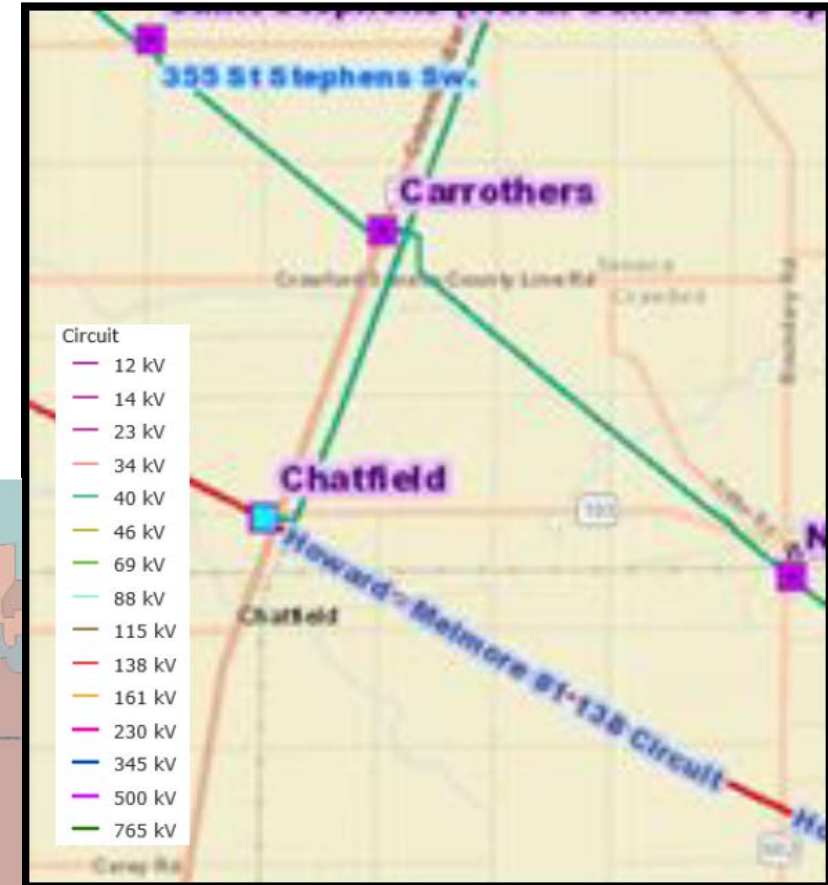

# AEP Transmission Zone M-3 Process Carrothers

**Need Number:** AEP-2019-OH021

**Process Stage:** Submission of Supplemental Project for inclusion in the Local Plan 10/3/2019

**Selected Solution:**

At Carrothers 69 kV station, replace line MOAB Y with a new 3000 A 40 kA circuit breaker and replace/upgrade relaying at Carrothers and Chatfield stations to accommodate new breaker.

**Estimated Cost:** \$2.0M

**Projected In-Service:** 9/02/2022

**Supplemental Project ID:** S2009

**Project Status:** Scoping

**Model:** N/A

**Existing:**

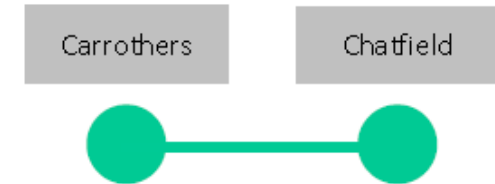

Legend	
500 kV	
345 kV	
138 kV	
69 kV	
34.5 kV	
23 kV	
New	

**Proposed:**

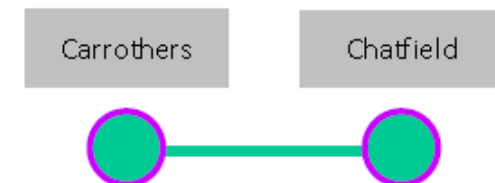

# AEP Transmission Zone M-3 Process Vassell/Sunbury

**Need Number:** AEP-2019-OH022

**Process Stage:** Submission of Supplemental Project for inclusion in the Local Plan 10/3/2019

**Previously Presented:**

Needs Meeting 5/20/2019

Solutions Meeting 6/17/2019

**Project Driver:**

Customer Service

**Specific Assumption Reference:**

AEP Guidelines for Transmission Owner Identified Needs (AEP Assumptions Slide 7)

**Problem Statement:**

Transformation at the 34.5/13 kV Sunbury station failed leading to the immediate need to install a 138/13 kV skid station at Vassell station to continue serving customer load. AEP-Ohio has requested to remove the existing temporary skid station outside Vassell station and to replace it with a new 138 kV delivery point installation at Vassell station.

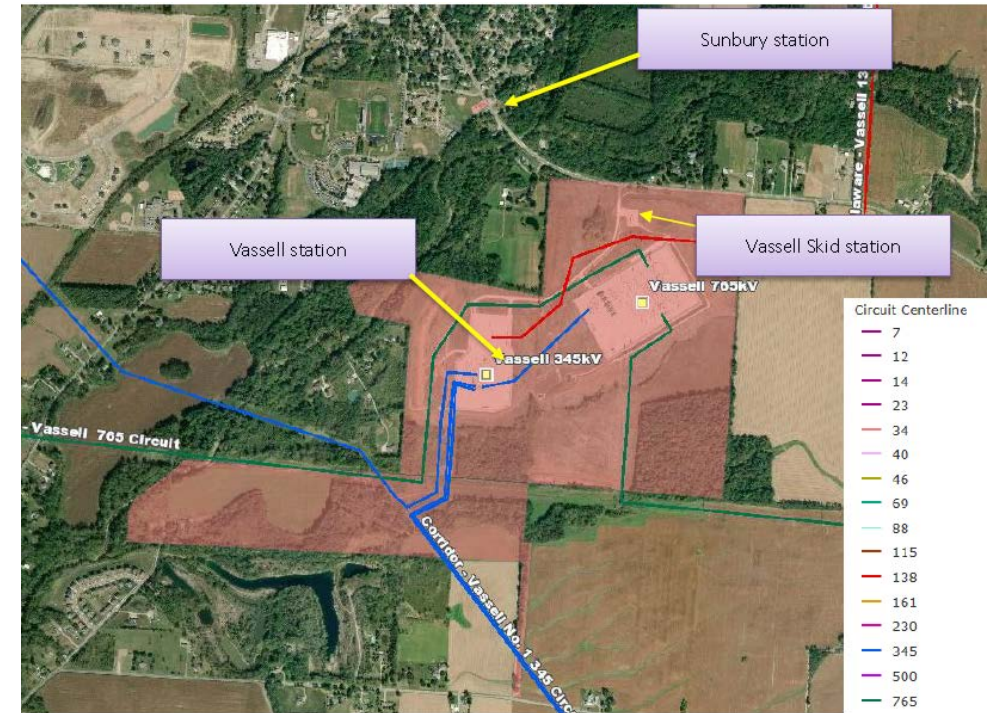

# AEP Transmission Zone M-3 Process Vassell/Sunbury

**Need Number:** AEP-2019-OH022

**Process Stage:** Submission of Supplemental Project for inclusion in the Local Plan 10/3/2019

**Selected Solution:**

At Vassell station, install 138 kV 4,000 A 63 kA CB and 138 kV bus extension to support connection of customer transformer.

**S2010.1**

**Estimated Cost: \$1.3M**

Remove and retire Sunbury 34.5 kV Station. **S2010.2**

**Estimated Cost: \$0.5M**

**Total Estimated Cost: \$1.8M**

**Projected In-Service: 12/09/2020**

**Supplemental Project ID: S2010.1 - .2**

**Project Status: Scoping**

**Model: 2023 RTEP**

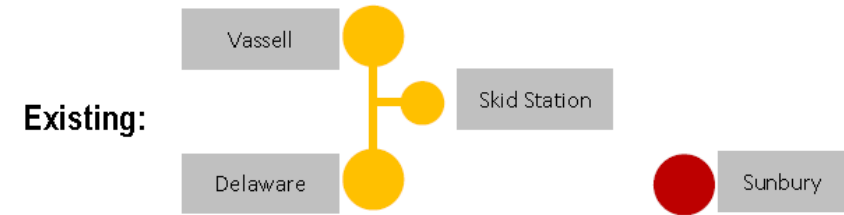

Legend	
500 kV	
345 kV	
138 kV	
69 kV	
34.5 kV	
23 kV	
New	

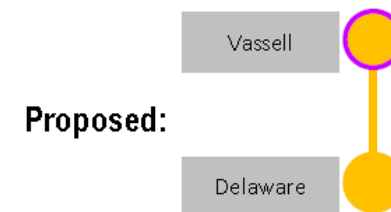



**Need Number:** AEP-2018-IM004

**Process Stage:** Submission of Supplemental Project for inclusion in the Local Plan 10/3/2019

**Previously Presented:**

Needs Meeting 10/26/2019

Solutions Meeting 4/23/2019

**Project Driver:**

Equipment Condition/Performance/Risk

**Specific Assumption Reference:**

AEP Guidelines for Transmission Owner Identified Needs (AEP Assumptions Slide 8)

**Problem Statement:**

3M Station 69 kV Station

- Breaker A 1967 FK oil filled breakers without oil containment.
- Fault Operations: CB A(23) – Recommended (10)

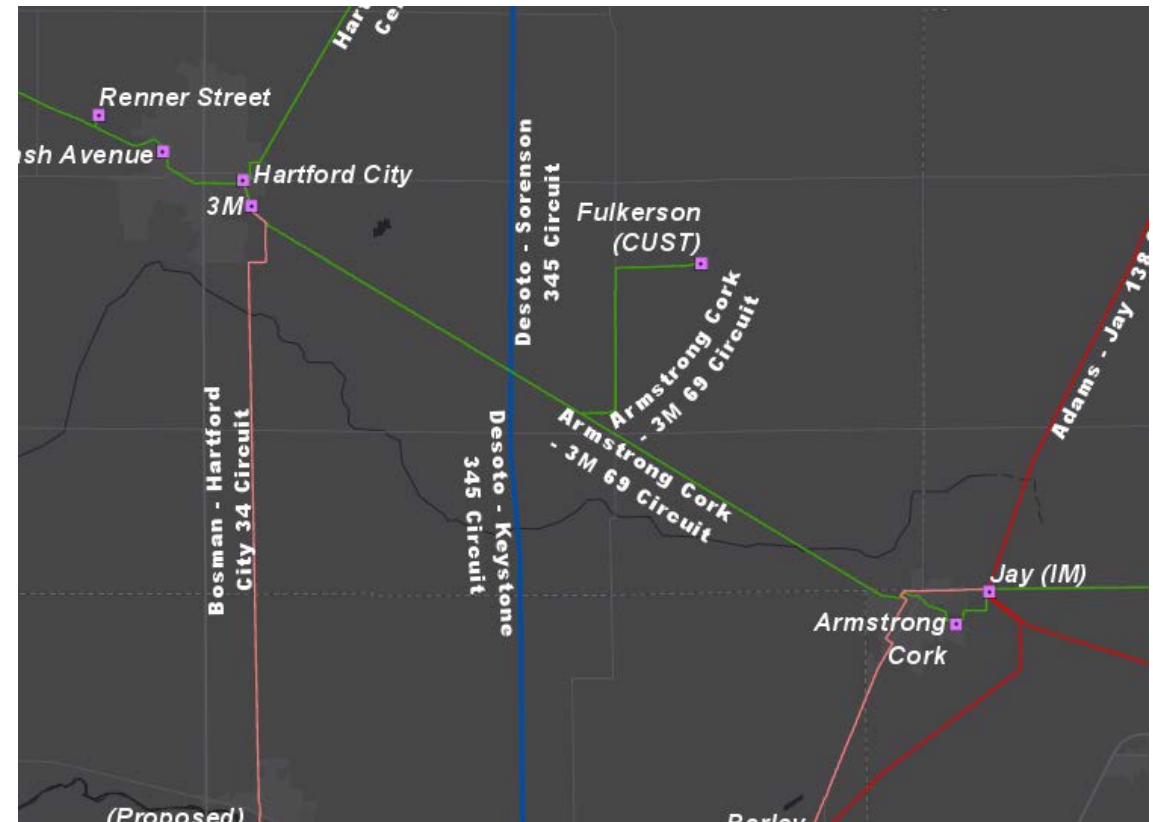

**Need Number:** AEP-2018-IM004

**Process Stage:** Submission of Supplemental Project for inclusion in the Local Plan 10/3/2019

**Selected Solution:**

3M 69 kV

Transmission will rebuild the full through-path of 3M station in the plot of land directly south of the existing 3M station. This through path includes one 69 kV breaker toward Jay station and a MOAB toward Hartford City station.

Transmission was approached by I&M Distribution with their needs at 3M station after the initial read of the transmission needs. In working with I&M Distribution on the best solution to address both T and D needs at 3M, it was determined the best approach would be to build in the clear at an adjacent site to minimize the outages while addressing both sets of needs.

**Estimated Cost:** \$1.35 M

**Projected In-Service:** 6/1/2022

**Supplemental Project ID:** S2011

**Project Status:** Scoping

**Model:** N/A

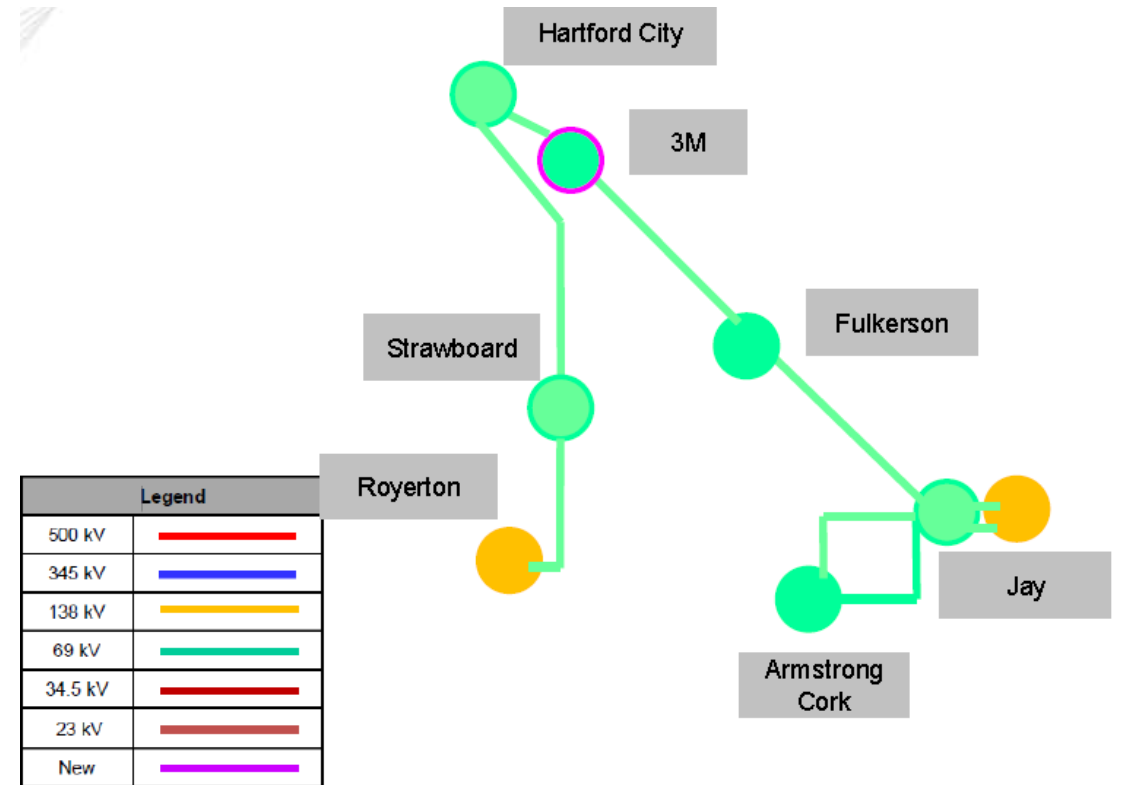

# AEP Transmission Zone M-3 Process Elwood Area

**Need Number:** AEP-2018-IM010

**Process Stage:** Submission of Supplemental Project for inclusion in the Local Plan 10/3/2019

**Previously Presented:**

Needs Meeting 10/26/2018

Solutions Meeting 4/23/2019

**Project Driver:**

Equipment Condition/Performance/Risk

**Specific Assumption Reference:**

AEP Guidelines for Transmission Owner Identified Needs (AEP Assumptions Slide 8)

**Problem Statement:**

Jonesboro – South Summitville

- 1930's wood crossarm construction
- #2 copper
- Over the past 10 years this line has had 128 structures require active maintenance with the majority being wood rot. This trend is expected to increase as the line ages.
- 68 structures currently have an open condition

South Elwood

- Breaker "C"
- 1951 FK oil type with no oil containment
- Fault Operations: CB C(19) – Recommended (10)

Transformer 1 – 1955 vintage

Type O Westinghouse bushings

- Increasing power factor
- Increasing Carbon Monoxide
- Failed internal heater circuit.
- Physically obstructs other station assets.

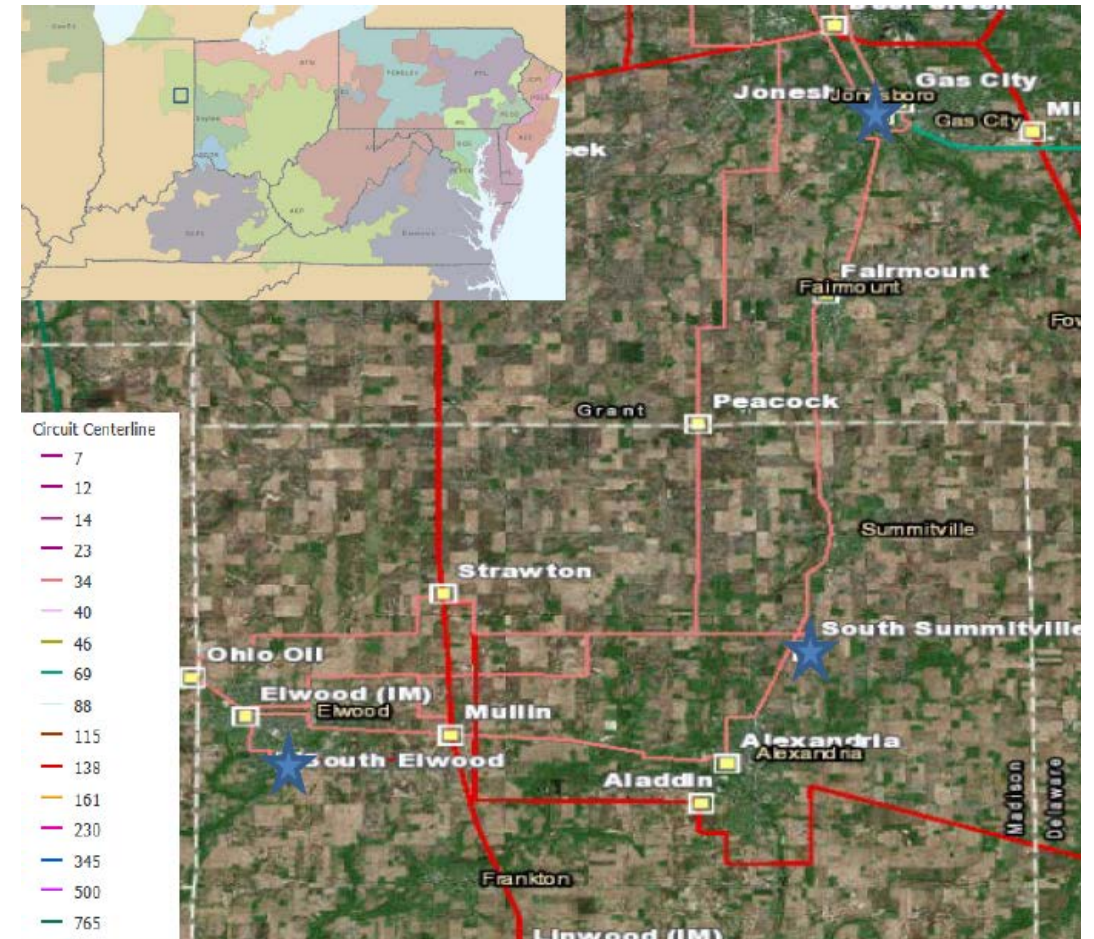

# AEP Transmission Zone M-3 Process Elwood Area

**Need Number:** AEP-2018-IM010

**Process Stage:** Submission of Supplemental Project for inclusion in the Local Plan 10/3/2019

**Previously Presented:**

Needs Meeting 10/26/2018

Solutions Meeting 4/23/2019

**Project Driver:**

Equipment Condition/Performance/Risk

**Specific Assumption Reference:**

AEP Guidelines for Transmission Owner Identified Needs (AEP Assumptions Slide 8)

**Problem Statement:**

Fairmount

Breakers "A" and "B"

- Fault Operations: A(75) B(99) – Recommended(10)

Transformer 1 – 1972 vintage

- High Carbon Dioxide level
- Dielectric issues

Peacock

Breaker "A"

- 1969 PR Oil breaker without containment

- Fault Operations: A(154) – Recommended(10)

Transformer 1 – 1951 Vintage

- High levels of Ethane, Methane, and CO2.
- Increasing Insulation power factor.

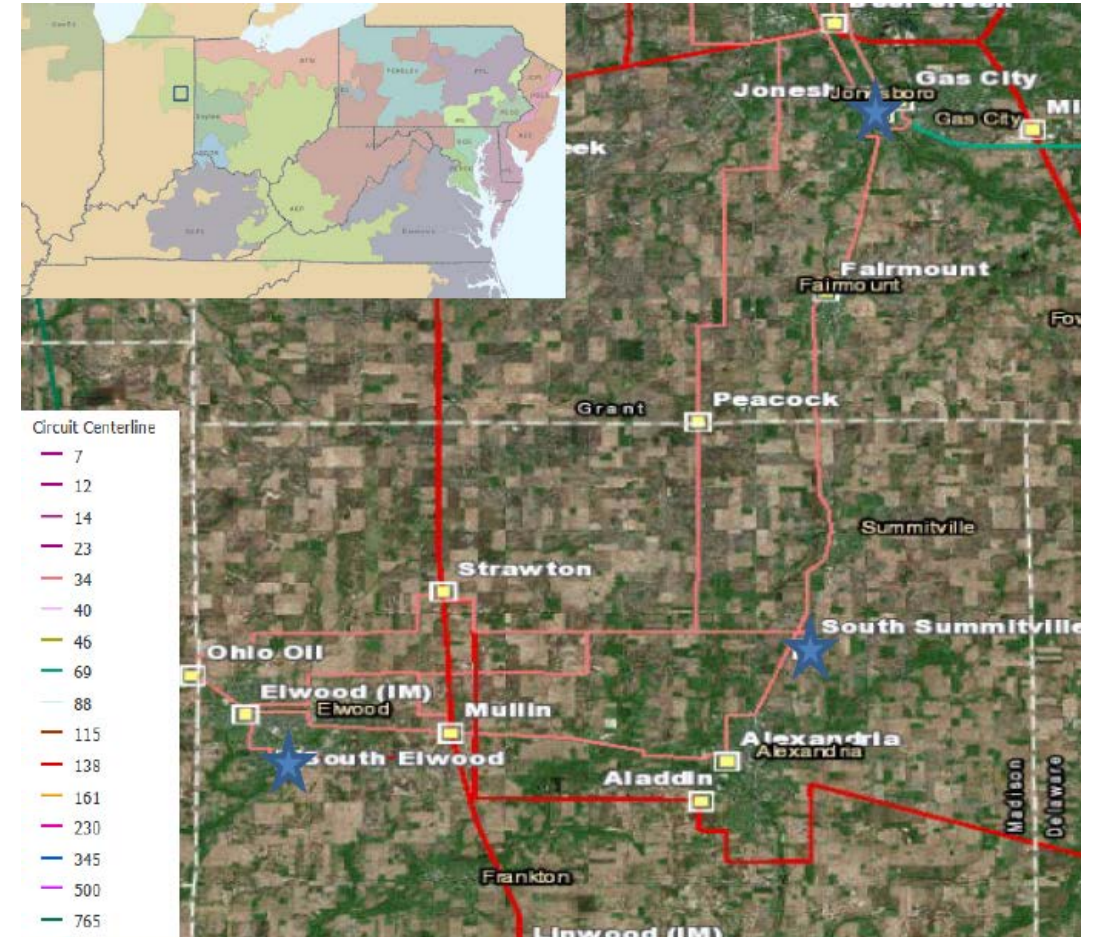

# AEP Transmission Zone M-3 Process Elwood Area

**Need Number:** AEP-2018-IM010

**Process Stage:** Submission of Supplemental Project for inclusion in the Local Plan 10/3/2019

**Previously Presented:**

Needs Meeting 10/26/2018

Solutions Meeting 4/23/2019

**Project Driver:**

Customer Service/Operational Flexibility & Efficiency

**Specific Assumption Reference:**

AEP Guidelines for Transmission Owner Identified Needs (AEP Assumptions Slide 8)

**Problem Statement:**

Both AEP Transmission and AEP distribution have received multiple requests for economic development in this area.

The current system would require significant rework in order to facilitate these requests, and the timeline for those fixes are not conducive to customer timelines.

The 34.5 kV system is subject to "Drop and Pick" operating procedure. This operating procedure has been an issue for I&M Distribution operations as it results in less reliable service for the customer and causes outages that could otherwise be avoided.

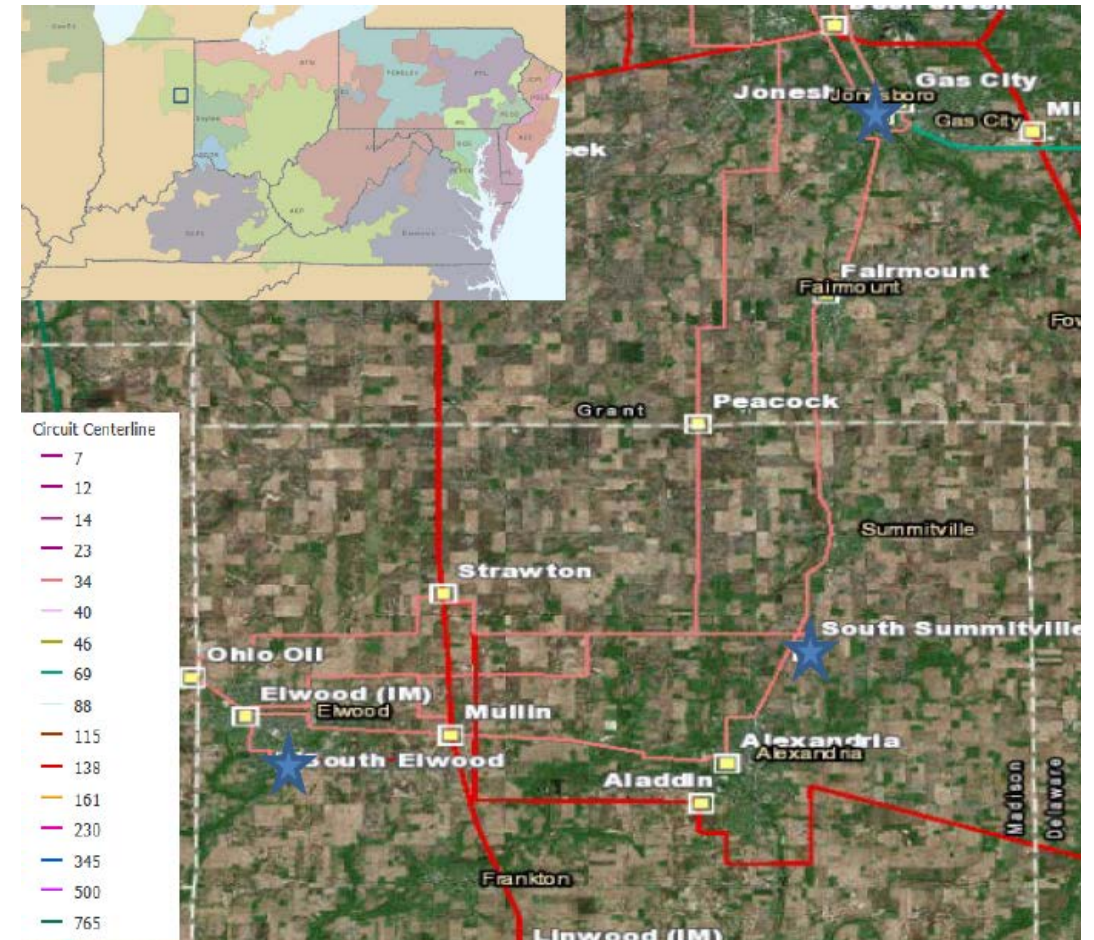

# AEP Transmission Zone M-3 Process Deer Creek CB

**Need Number:** AEP-2018-IM025

**Process Stage:** Submission of Supplemental Project for inclusion in the Local Plan 10/3/2019

**Previously Presented:**

Needs Meeting 1/11/2019

Solutions Meeting 4/23/2019

**Project Driver:**

Equipment Condition/Performance/Risk

**Specific Assumption Reference:**

AEP Guidelines for Transmission Owner Identified Needs (AEP Assumptions Slide 8)

**Problem Statement:**

Deer Creek 34.5 kV

- Breakers "U" 1950 vintage FK oil breakers without containment
- Fault Operations: CB U(38)– Recommended(10)



# AEP Transmission Zone M-3 Process Aladdin

**Need Number:** AEP-2019-IM005

**Process Stage:** Submission of Supplemental Project for inclusion in the Local Plan 10/3/2019

**Previously Presented:**

Needs Meeting 2/20/2019

Solutions Meeting 4/23/2019

**Project Driver:**

Operational Flexibility and Efficiency

**Specific Assumption Reference:**

AEP Guidelines for Transmission Owner Identified Needs (AEP Assumptions Slide 8)

**Problem Statement:**

**Associated Needs:** AEP-2018-IM010

Strawton – Arnold Hogan 138 kV

- This line currently has 4 MOABS in series (2 at Aladdin and 2 at Jones Creek) which is above AEP's max of 3.



# AEP Transmission Zone M-3 Process Elwood Area

**Need Number:** AEP-2018-IM010, AEP-2018-IM025, AEP-2019-IM005

**Process Stage:** Submission of Supplemental Project for inclusion in the Local Plan 10/3/2019

**Selected Solution:**

Jonesboro – South Summitville 34.5 kV line:

Retire the ~10.5 mile South Summitville – Jonesboro 34.5 kV line. **S2012.1 Estimated Cost:** \$1.6M

Jonesboro 34.5 kV station:

Retire Jonesboro station **S2012.2 Estimated Cost:** \$0.3M

Dean 69 kV station & Fairmount/Peacock 34.5 kV stations:

Install the new 69 kV Dean station with a single bus tie breaker to take replace the 34.5 Fairmount and Peacock stations  
**S2012.3 Estimated Cost:** \$1.5M

South Elwood 138/34.5 kV station:

Replace the 138/34.5 kV XFR 1 and the existing 34.5 kV breaker with a 138/69 kV XFR and a 69 kV rated breaker  
**S2012.4 Estimated Cost:** \$3.4M

Deer Creek 138/69/34.5 kV station:

Install a 3 breaker 69 kV ring bus in the clear to enable the connection of the now 69 kV rated South Summitville line. Add a 138 kV breaker to the high side of XFR 1 to replace the moab.  
**S2012.5 Estimated Cost:** \$6.4M

Aladdin 138 kV station:

Install a 138 kV bus tie breaker at Aladdin station **S2012.6 Estimated Cost:** \$1M

Elwood 34.5 kV station

Rebuild Elwood in the clear as an in and out station with a bus tie breaker. **S2012.7 Estimated Cost:** \$0M

Strawton Area work

Energize Ohio Oil, South Summitville, Strawton and the lines connecting them to 69 kV. These stations and lines are already built to this standard. **S2012.8 Estimated Cost:** \$2.1M

**Estimated Cost:** \$16.3M

**Projected In-Service:** 10/1/2021

**Supplemental Project ID:** S2012.1 - .8

**Project Status:** Scoping

**Model:** 2024 RTEP

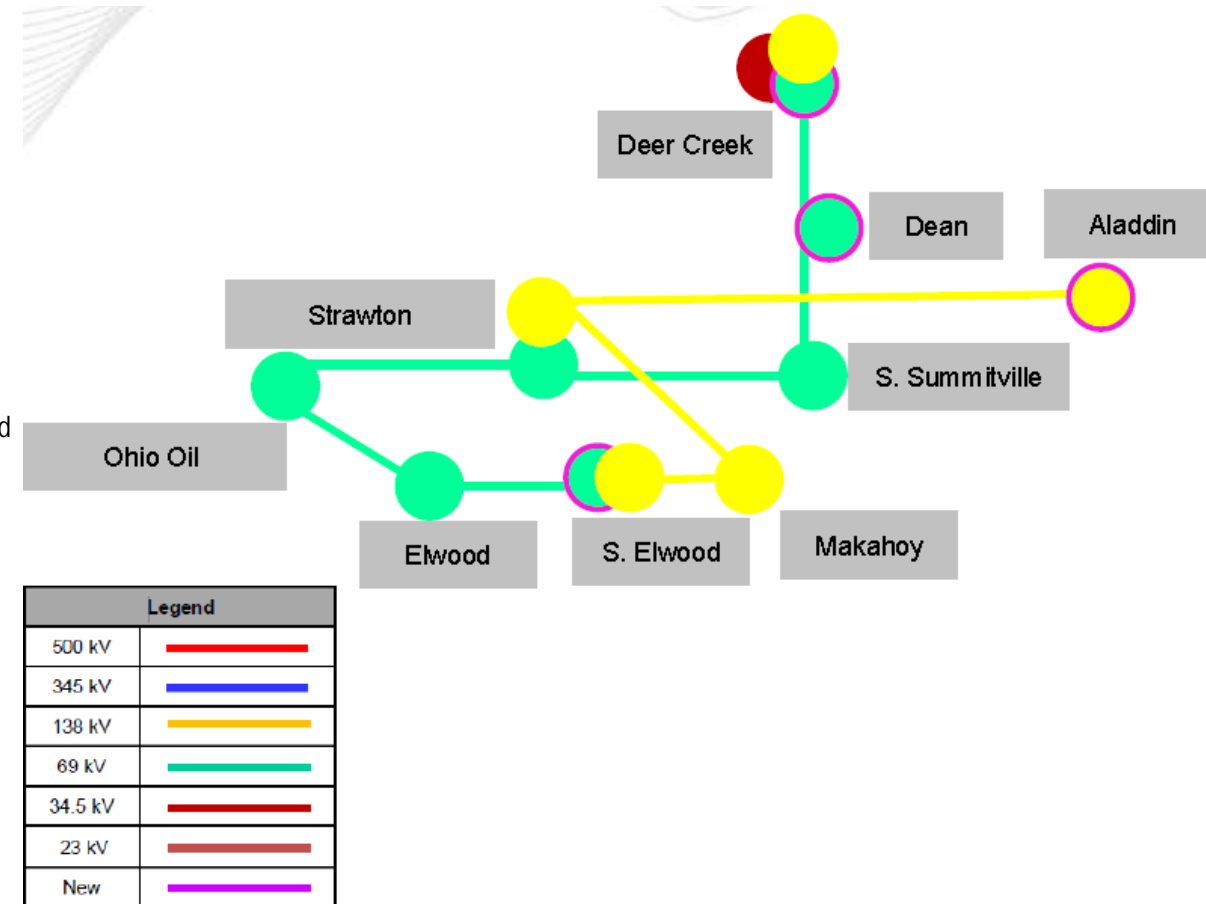



# AEP Transmission Zone M-3 Process Western Marion Area Improvements

**Need Number:** AEP-2018-IM017

**Process Stage:** Submission of Supplemental Project for inclusion in the Local Plan 10/3/2019

**Previously Presented:**

Needs Meeting 1/11/2019

Solutions Meeting 5/20/2019

**Project Driver:**

Equipment Condition/Performance/Risk

**Specific Assumption Reference:**

AEP Guidelines for Transmission Owner Identified Needs (AEP Assumptions Slide 8)

**Problem Statement:**

Deer Creek 34.5kV

- Breakers "K", "F", "M", "H", "V", "W"
  - 1949-62 vintage FK oil breakers without containment
  - Fault Operations: CB K(9) CB F(1) CB M(17) CB H(16) CB V(5) CB W(1) -Recommended(10)
  - CB W is over the recommended amount of switching operations.

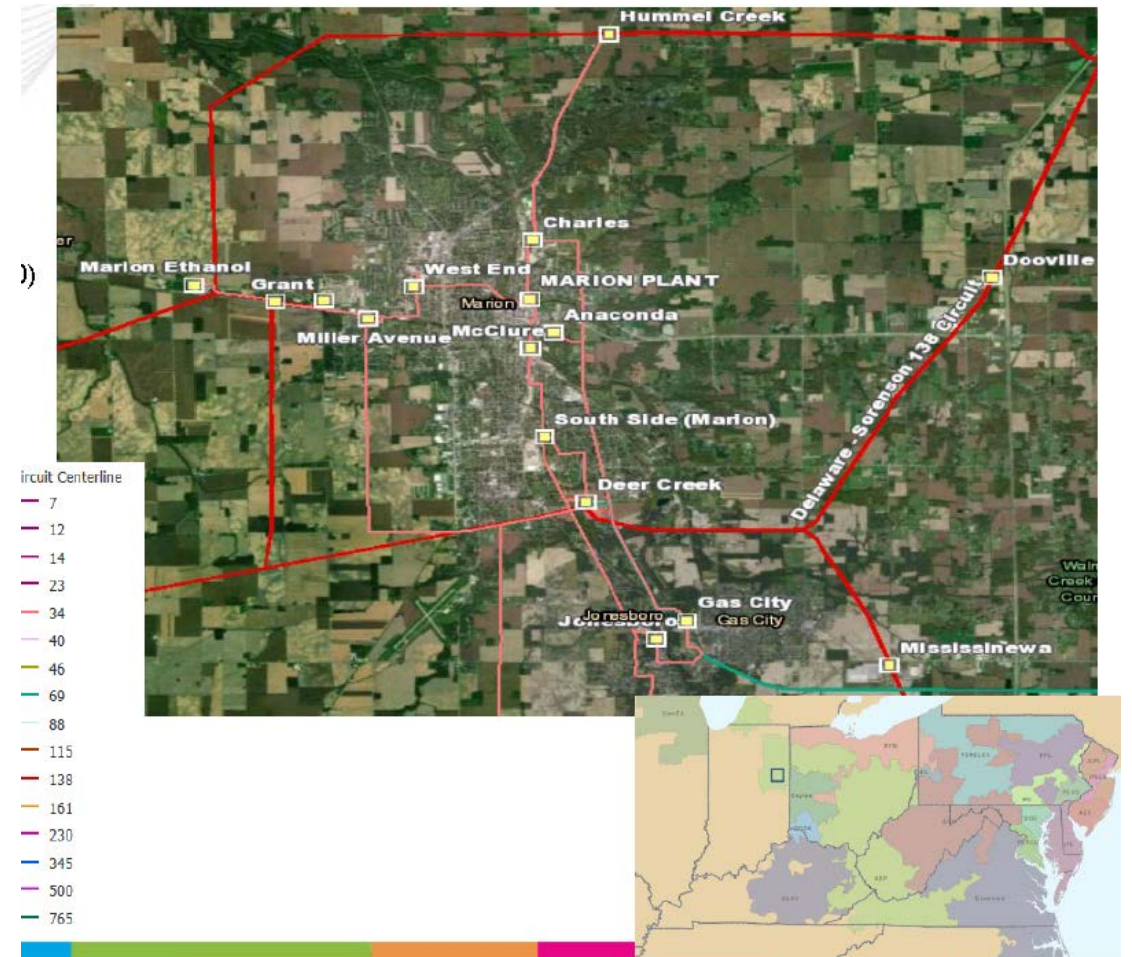

# AEP Transmission Zone M-3 Process Western Marion Area Improvements

**Need Number:** AEP-2018-IM017

**Process Stage:** Submission of Supplemental Project for inclusion in the Local Plan 10/3/2019

**Previously Presented:**

Needs Meeting 1/11/2019

Solutions Meeting 5/20/2019

**Project Driver:**

Equipment Condition/Performance/Risk

**Specific Assumption Reference:**

AEP Guidelines for Transmission Owner Identified Needs (AEP Assumptions Slide 8)

**Problem Statement:**

Deer Creek – Miller Ave 34.5kV (6.1 Miles)

- 1952 wood crossarm construction (age based on age of station)
- 3/0 copper
- Subject to 15 open B conditions
- Subject to 13 open A conditions
- In the past 10 years, 37 structures have had active maintenance performed. This is expected to increase as line ages.

Grant – West End 34.5kV (2.1 Miles)

- 1950 wood crossarm construction (age based on age of West End station)
- Legacy Cap and Pin type insulators
- Subject to 5 open conditions
- In the past 10 years, has had to have 65 open conditions addressed

Deer Creek – Marion 34.5kV (3.6 Miles)

- 1949 wood crossarm construction (age based on age of Deer Creek breaker)
- Legacy Cap and Pin type insulators
- Subject to 5 open conditions
- In the past 10 years, has had to have 26 open conditions addressed

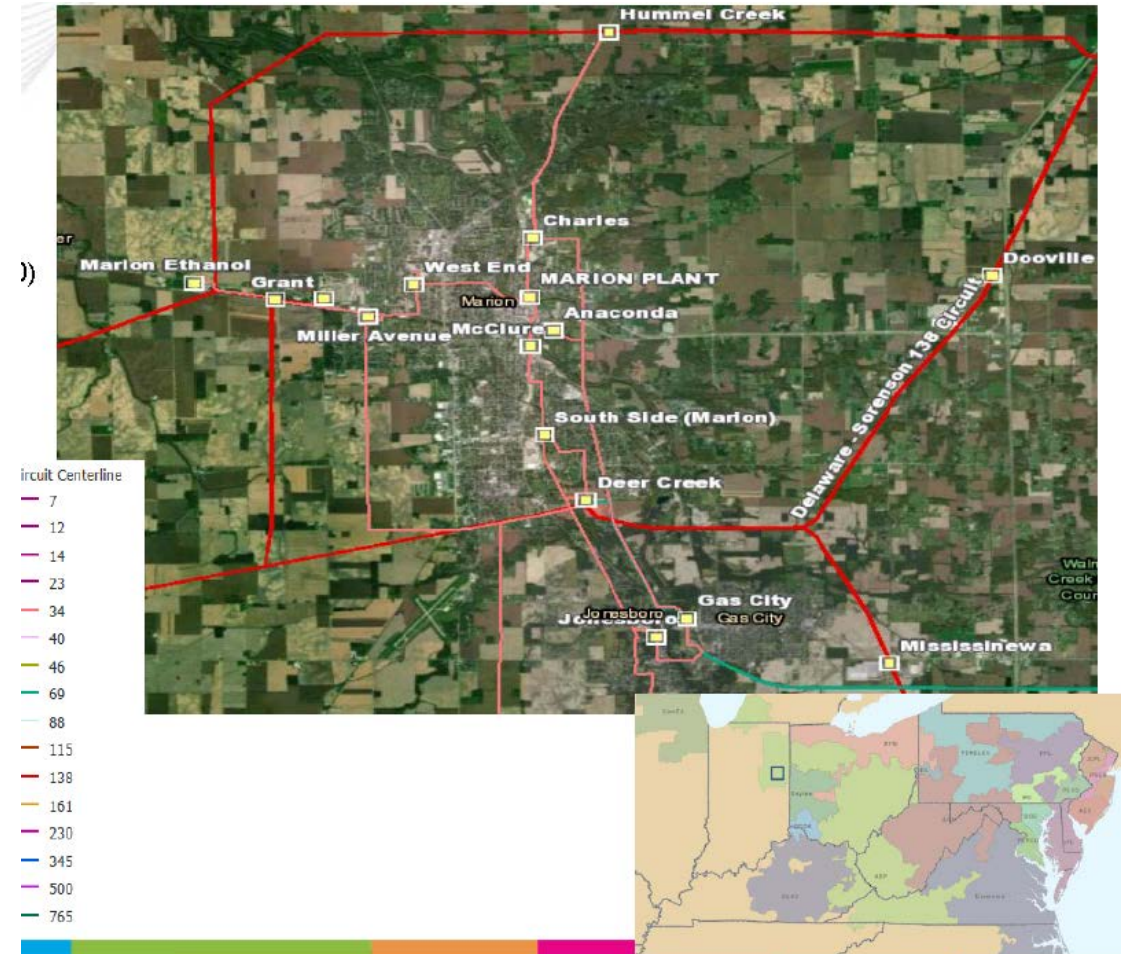

# AEP Transmission Zone M-3 Process Western Marion Area Improvements

**Need Number:** AEP-2018-IM017

**Process Stage:** Submission of Supplemental Project for inclusion in the Local Plan 10/3/2019

**Previously Presented:**

Needs Meeting 1/11/2019

Solutions Meeting 5/20/2019

**Project Driver:**

Operational Flexibility and Efficiency

**Specific Assumption Reference:**

AEP Guidelines for Transmission Owner Identified Needs (AEP Assumptions Slide 8)

**Problem Statement:**

Deer Creek – Marion Plant 34.5 kV

- 4 MOABs in series

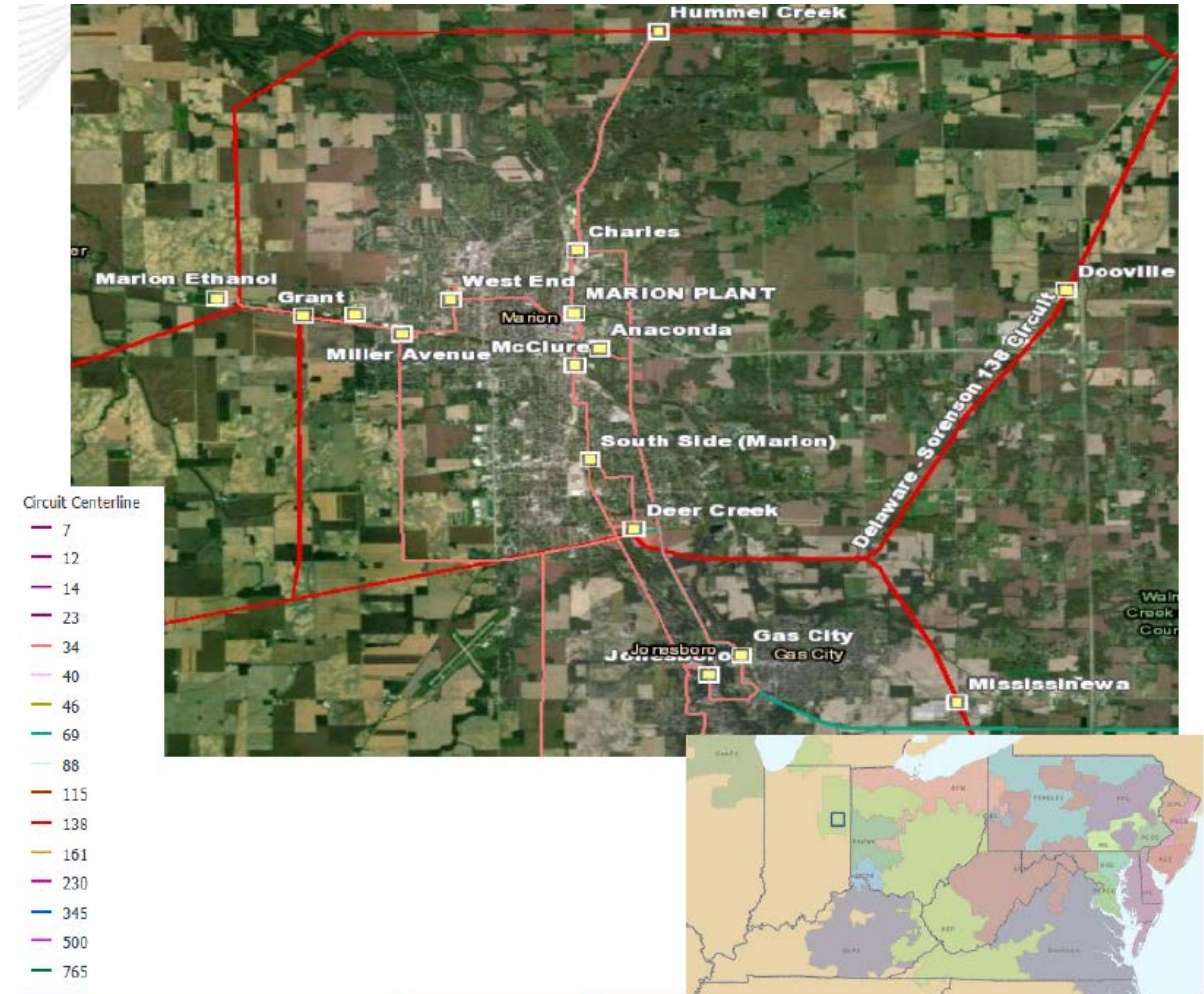

# AEP Transmission Zone M-3 Process Western Marion Area Improvements

**Need Number:** AEP-2018-IM017

**Process Stage:** Submission of Supplemental Project for inclusion in the Local Plan 10/3/2019

**Selected Solution:**

## West End – Grant 34.5kV line

Rebuild the Grant – West End 34.5 kV 2.2 mile line using 556.5 ACSR **S2013.1**  
**Cost: \$4M**

## Deer Creek – Miller Ave 34.5kV line

Retire the Deer Creek – Miller Ave 34.5 kV line **S2013.2** **Cost: \$0.6M**

## Deer Creek – Marion Plant 34.5kV line

Rebuild the Deer Creek – Marion Plant 34.5 kV 3.5 mile line using 556.5 ACSR **S2013.3** **Cost: \$9M**

## Deer Creek East Tap 34.5kV line

Retire the Deer Creek East 34.5 kV line **S2013.4** **Cost: \$0.3M**

## Atlas Tap 34.5kV line

Re-route the Atlas Tap into West End station **S2013.5** **Cost: \$0.5M**

## Deer Creek 138/69/34.5kV station

Retire 34.5 kV breakers 'H', 'F', 'K' and 'V'. Retire the 34.5 kV cap banks. Install the old 69 kV rated breaker "J" toward South Side station. Re-use breakers "A" and "E" from South Summitville to replace breaker "M" and "W" at Deer Creek. **S2013.6**  
**Cost: \$2M**

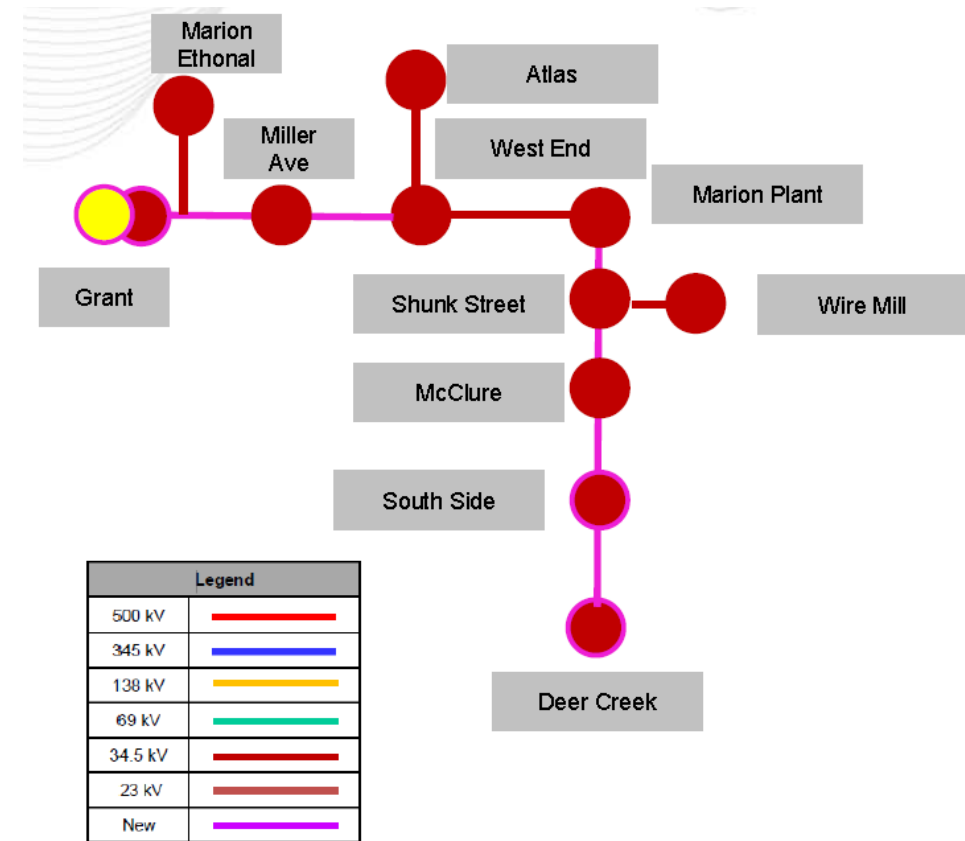

# AEP Transmission Zone M-3 Process Western Marion Area Improvements

**Need Number:** AEP-2018-IM017

**Process Stage:** Submission of Supplemental Project for inclusion in the Local Plan 10/3/2019

**Selected Solution (con't):**

**South Side 34.5kV station**

Install a 69 kV rated breaker toward Marion Plant **S2013.7 Cost: \$1.3M**

**Grant 138/34.5kV station**

Install a 14.4 Mvar 138 kV Cap Bank at Grant station and a 138 kV high side circuit switcher **S2013.8 Cost: \$1.3M**

**Total Estimated Cost:** \$19.5M

**Projected In-Service:** 6/1/2022

**Supplemental Project ID:** S2013.1 - .8

**Project Status:** Scoping

**Model:** N/A

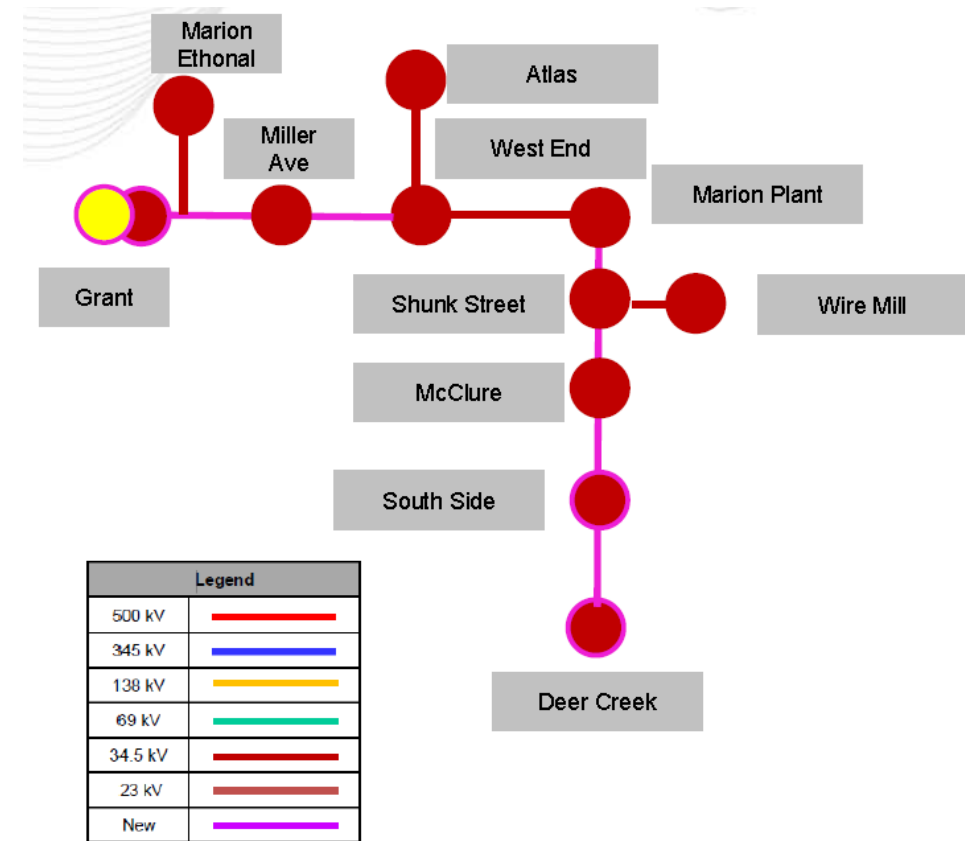

# AEP Transmission Zone M-3 Process

## Jay – College Corner

**Need Number:** AEP-2018-IM018

**Process Stage:** Submission of Supplemental Project for inclusion in the Local Plan 10/3/2019

**Previously Presented:**

Needs Meeting 1/11/2019

Solutions Meeting 5/20/2019

**Project Driver:**

Equipment Condition/Performance/Risk

**Specific Assumption Reference:**

AEP Guidelines for Transmission Owner Identified Needs (AEP Assumptions Slide 8)

**Problem Statement:**

Jay – College Corner 138 kV line

- 1941 & 1951 vintage wood H frame line
- Non-standard EHS Steel Shield Wire
- The most recent 6-year inspection showed 91 open conditions (A:52 B:39) with the majority being structural issues.
- In the past 10 years 97 structures have had to have active maintenance on them. This trend is expected to increase as the structures and conductor age.
- In the past 5 years AEP has experienced 13 scheduled outages and 2 forced momentary outages.

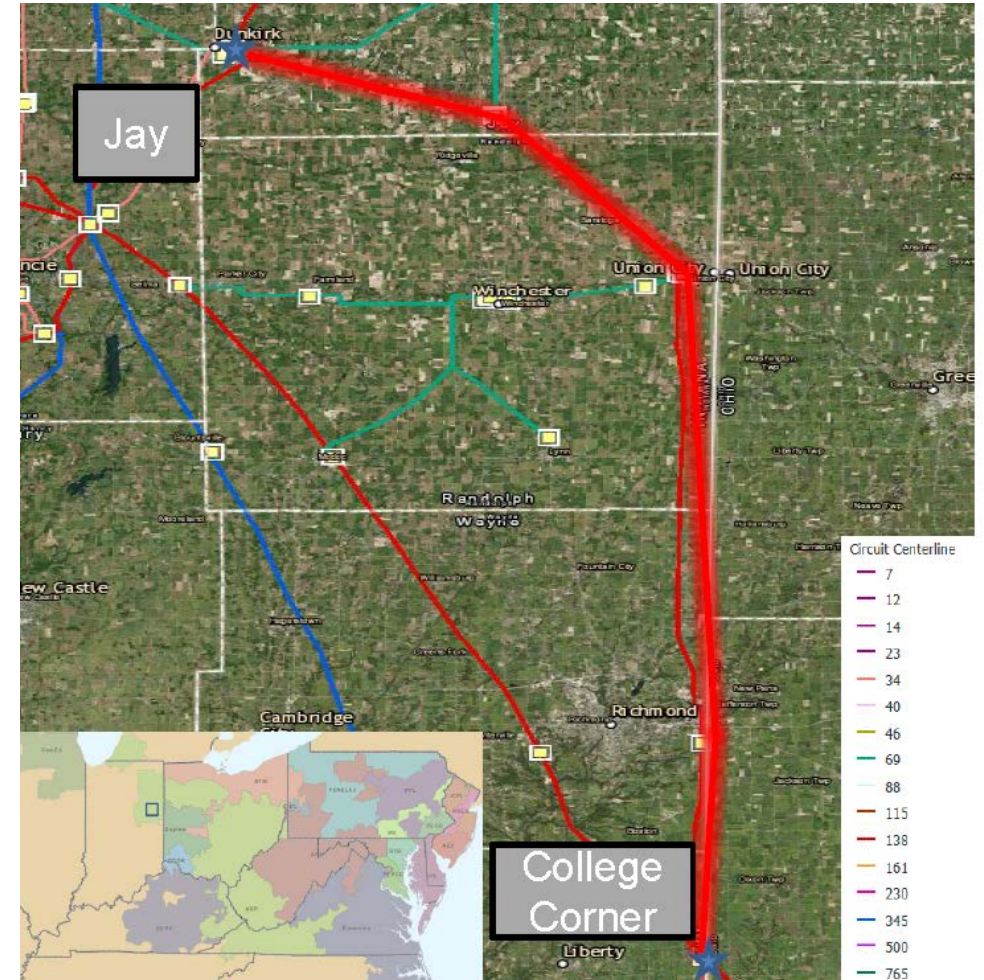

# AEP Transmission Zone M-3 Process Jay – College Corner

**Need Number:** AEP-2018-IM018

**Process Stage:** Submission of Supplemental Project for inclusion in the Local Plan 10/3/2019

**Selected Solution:**

Rebuild the 62 mile College Corner – Jay 138 kV line as single circuit 138 kV. New conductor will be 795 ACSR

**Estimated Cost:** \$113.5M

**Projected In-Service:** 12/01/2023

**Supplemental Project ID:** S2014

**Project Status:** Scoping

**Model:** N/A



Legend	
500 kV	
345 kV	
138 kV	
69 kV	
34.5 kV	
23 kV	
New	

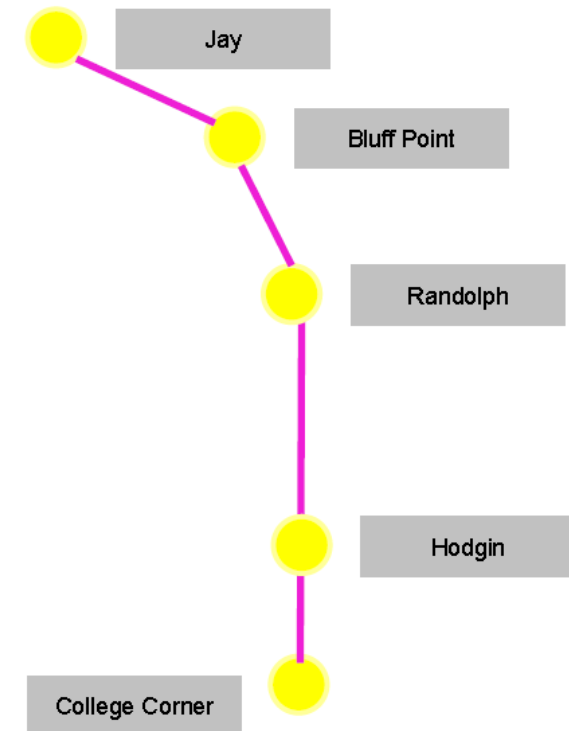





# AEP Transmission Zone M-3 Process Northern Muncie

**Need Number:** AEP-2018-IM020

**Process Stage:** Submission of Supplemental Project for inclusion in the Local Plan 10/3/2019

**Selected Solution:**

Delaware – Jay 34.5 kV line

Retire the Delaware – Jay ~20 mile 34.5kV line. **S2015.1**

**Cost: \$4.6M**

Delaware – Haymond 34.5k V line

Rebuild the 2.5 miles from Delaware to a point near Centennial Road using 556.5 ACSR (south of the road the line is newer construction). **S2015.2**

**Cost: \$6.5M**

Desoto – Jay 138kV line

Work required to remove, reterminate and reconfigure this line to allow for the Perch Extension connection. **S2015.3**

**Cost: \$2.1M**

Perch Extension 138 kV line

Install the new ~1 mile perch Extension in order to connect the new station to the Desoto – Jay 138kV line. **S2015.4**

**Cost: \$3.6M**

Delaware 138/34.5 kV station

Rebuild the 34.5kV voltage class as a ring bus by installing 3 new 69kV rated breakers and reusing exiting breakers "N" "G" and "D" **S2015.5**

**Cost: \$5.9M**

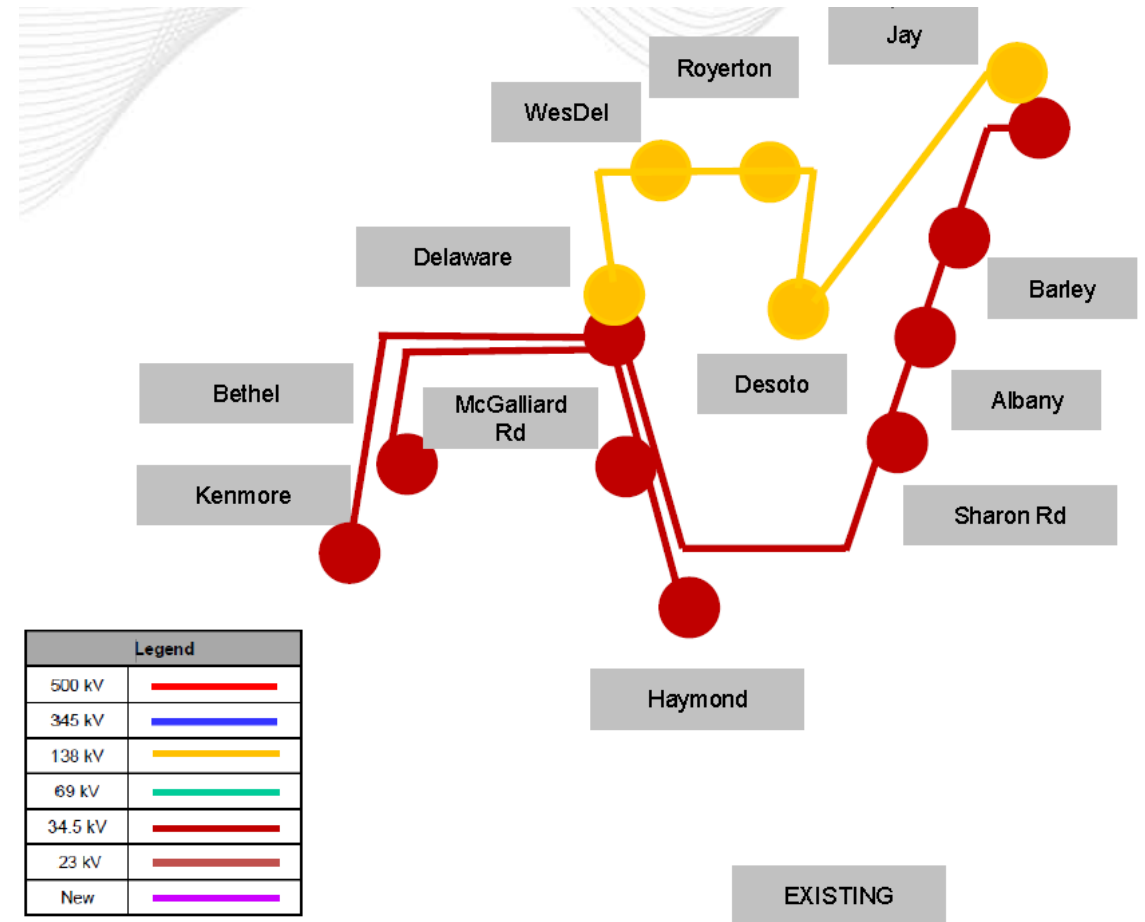

# AEP Transmission Zone M-3 Process Northern Muncie

**Need Number:** AEP-2018-IM020

**Process Stage:** Submission of Supplemental Project for inclusion in the Local Plan 10/3/2019

**Selected Solution (con't):**

**Jay 138/69/34.5kV station**

Retire all 34.5kV equipment at this station **S2015.6**

**Cost: \$.3M**

**Perch 138kV Station**

Install the new in and out to 138 kV Perch station with two MOABs to allow retirements of the Delaware-Jay 34.5 kV line. Perch will pick up loads from retiring Sharon Road, Barley, and Albany stations. **S2015.7**

**Cost: \$1.7M**

**Total Estimated Cost: \$24.3M**

**Projected In-Service: 12/10/2021**

**Supplemental Project ID: S2015.1-.7**

**Project Status: Scoping**

**Model: N/A**

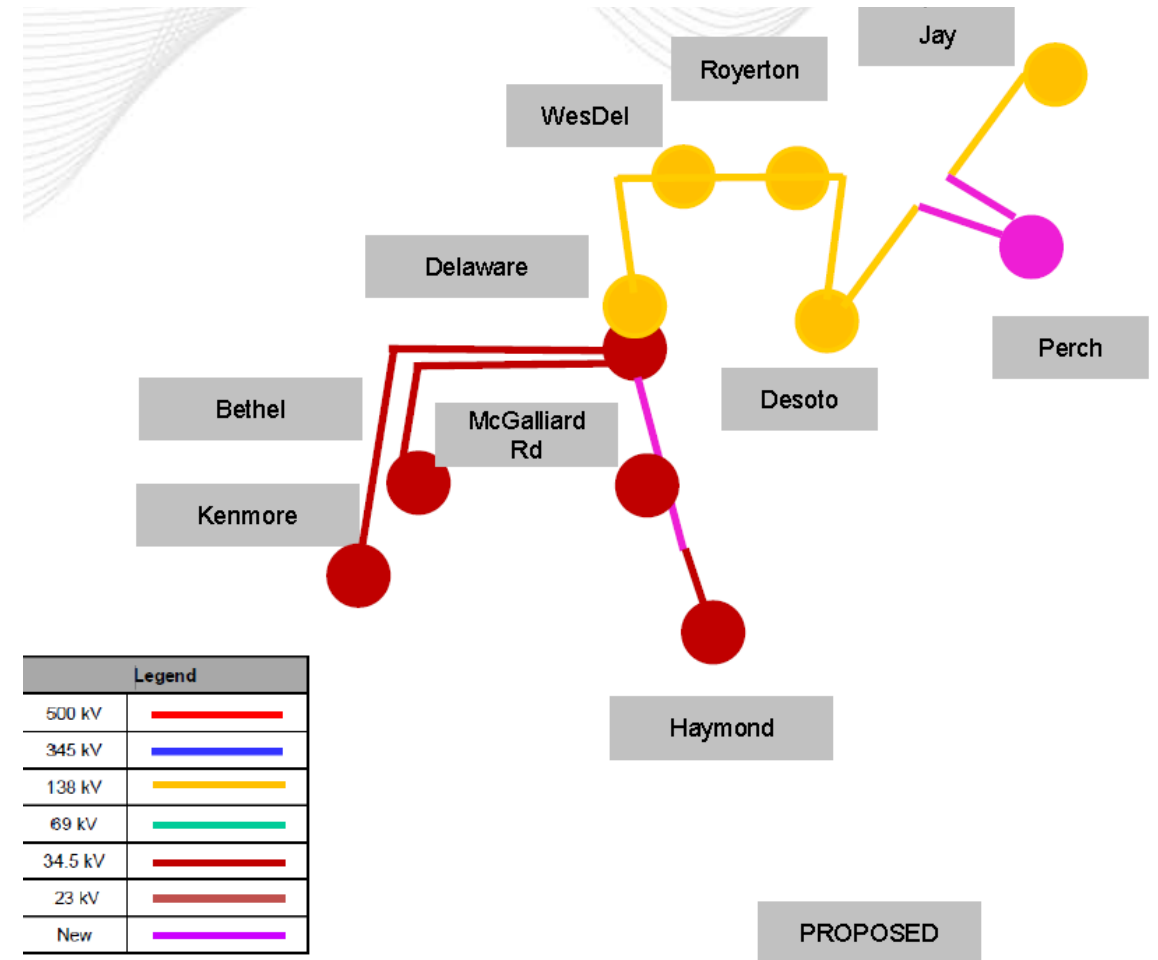

# AEP Transmission Zone M-3 Process Hogan - Kenmore

**Need Number:** AEP-2018-IM021

**Process Stage:** Submission of Supplemental Project for inclusion in the Local Plan 10/3/2019

**Previously Presented:**

Needs Meeting 10/26/2018

Solutions Meeting 5/20/2019

**Project Driver:**

Equipment Condition/Performance/Risk

**Specific Assumption Reference:**

AEP Guidelines for Transmission Owner Identified Needs (AEP Assumptions Slide 8)

**Problem Statement:**

Arnold Hogan – Kenmore 34.5 kV

- 1930's and 1960's vintage construction
- 3/0 copper and 336.4 ACSR conductor
- 15 of the 47 structures had to undergo active maintenance in the last 10 years and this trend is expected to rise as the line ages.
- Majority of current and past maintenance concerns relate to integrity of structures and crossarms

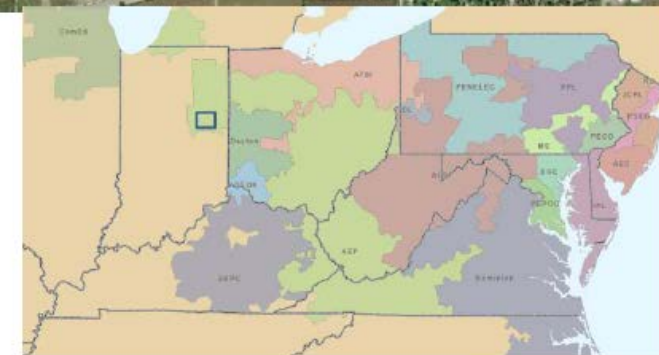

# AEP Transmission Zone M-3 Process Hogan - Kenmore

**Need Number:** AEP-2019-IM026

**Process Stage:** Submission of Supplemental Project for inclusion in the Local Plan 10/3/2019

**Previously Presented:**

Needs Meeting 2/20/2019

Solutions Meeting 5/20/2019

**Project Driver:**

Equipment Condition/Performance/Risk

**Specific Assumption Reference:**

AEP Guidelines for Transmission Owner Identified Needs (AEP Assumptions Slide 8)

**Problem Statement:**

Kenmore – 23rd street (Section is .53 miles) 34.5 kV

- Section has been identified as having multiple physically overloaded structures and must be addressed.

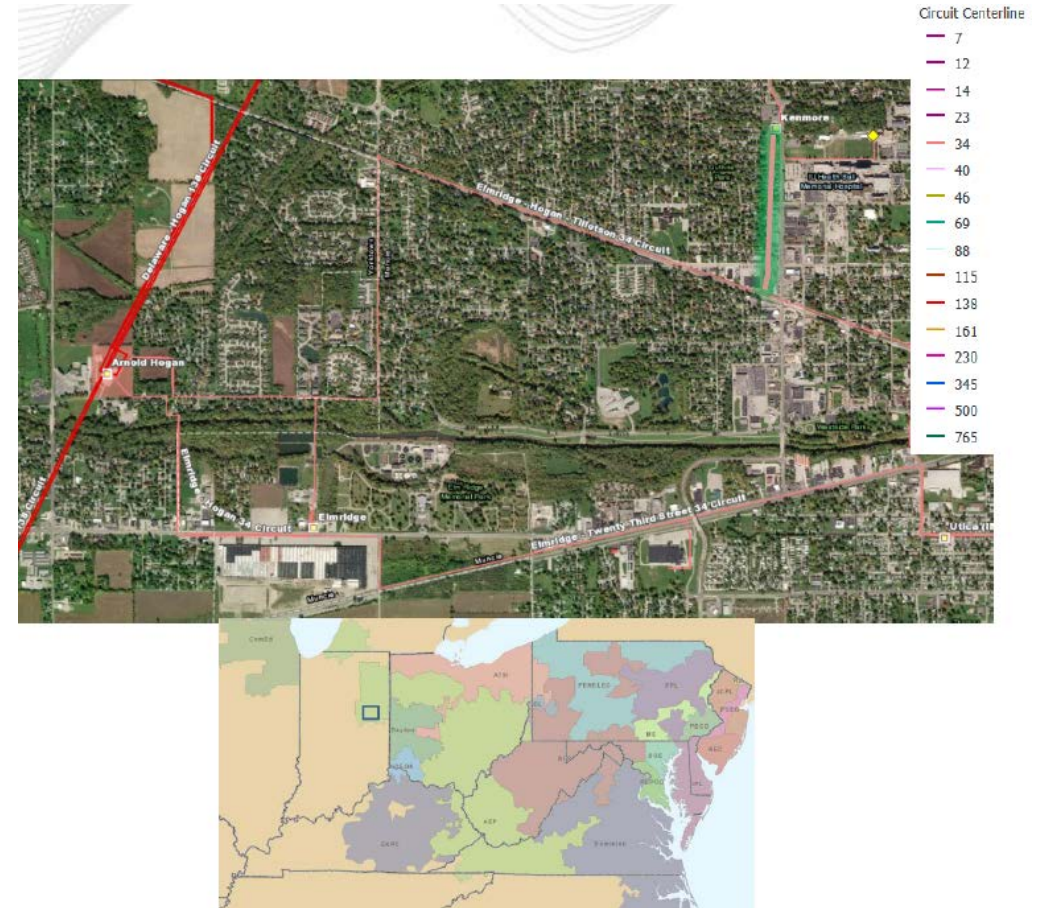

# AEP Transmission Zone M-3 Process Hogan - Kenmore

**Need Number:** AEP-2019-IM026 & AEP-2018-IM021

**Process Stage:** Submission of Supplemental Project for inclusion in the Local Plan 10/3/2019

**Selected Solution:**

Arnold Hogan – Kenmore 34.5kV (West Section):

Rebuild 1.3 miles in the clear from structure 1 to structure 47 utilizing double circuit 34.5kV line (69 rated) with only the north side strung. New conductor will be 556.5 ACSR **S2016.1**

**Cost: \$6.2M**

Arnold Hogan – Kenmore 34.5kV (East Section):

Rebuild the .5miles from STR 80 to Kenmore as underground construction. New conductor will be 1750KCMILL CU XLPE. **S2016.2**

**Cost: \$9.5M**

**Estimated Cost: \$15.7M**

**Projected In-Service: 6/1/2022**

**Supplemental Project ID: S2016.1-.2**

**Project Status: Scoping**

**Model: N/A**

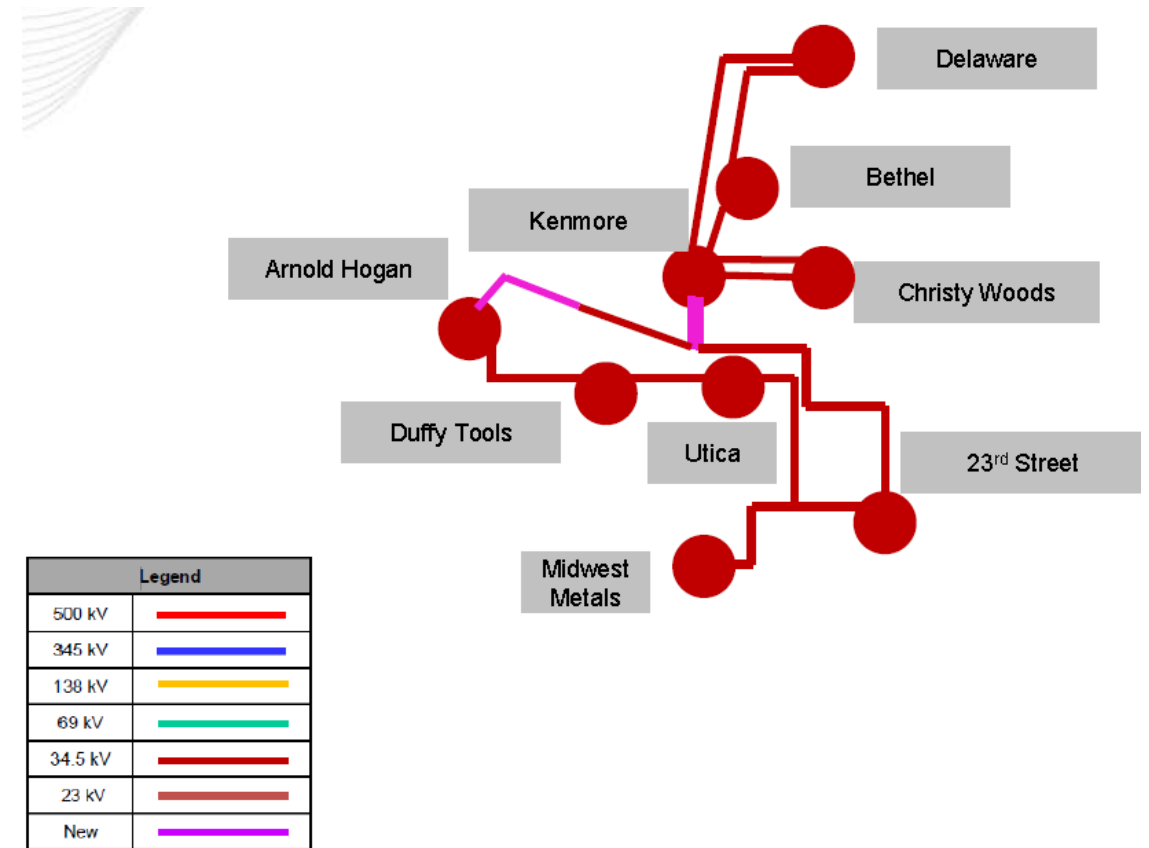

# AEP Transmission Zone M-3 Process Hummel Creek Station Rehab

**Need Number:** AEP-2018-IM022

**Process Stage:** Submission of Supplemental Project for inclusion in the Local Plan 10/3/2019

**Previously Presented:**

Needs Meeting 1/11/2019

Solutions Meeting 6/17/2019

**Project Driver:**

Equipment Condition/Performance/Risk

**Specific Assumption Reference:**

AEP Guidelines for Transmission Owner Identified Needs (AEP Assumptions Slide 8)

**Problem Statement:**

Hummel Creek 34.5 kV

Breakers "L" and "M"

- 1949-1950 vintage FK oil breaker without containment
- Fault Operations: CB M(33)– Recommended(10)

Gas City 34.5 kV

Breakers "A"

- 1940 vintage FK oil breaker without containment
- Fault Operations: CB A(50) – Recommended(10)

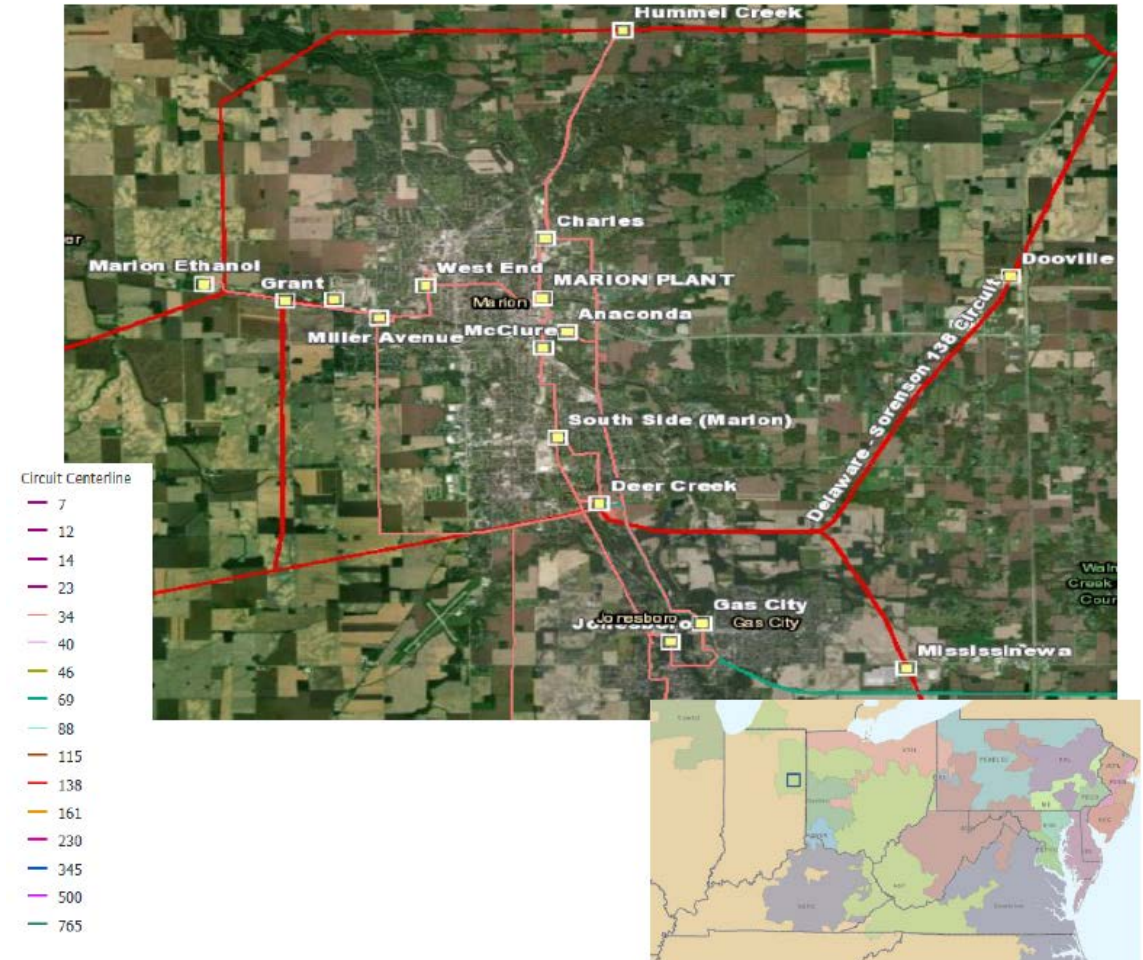

# AEP Transmission Zone M-3 Process Hummel Creek Station Rehab

**Need Number:** AEP-2018-IM022

**Process Stage:** Submission of Supplemental Project for inclusion in the Local Plan 10/3/2019

**Selected Solution:**

At Hummel Creek station, replace both 34.5kV breakers "L" and "M" with system spares. Install a high side circuit switcher on Hummel Creek's XFR 1. **S2017.1**

**Estimated Cost:** \$2.6M

At Gas City station, remove the existing 34.5kV breaker and re-use the existing switch as a MOAB. **S2017.2**

**Estimated Cost:** \$0M

**Total Estimated Cost:** \$2.6M

**Projected In-Service:** 12/1/2022

**Supplemental Project ID:** S2017.1 -.2

**Project Status:** Scoping

**Model:** N/A

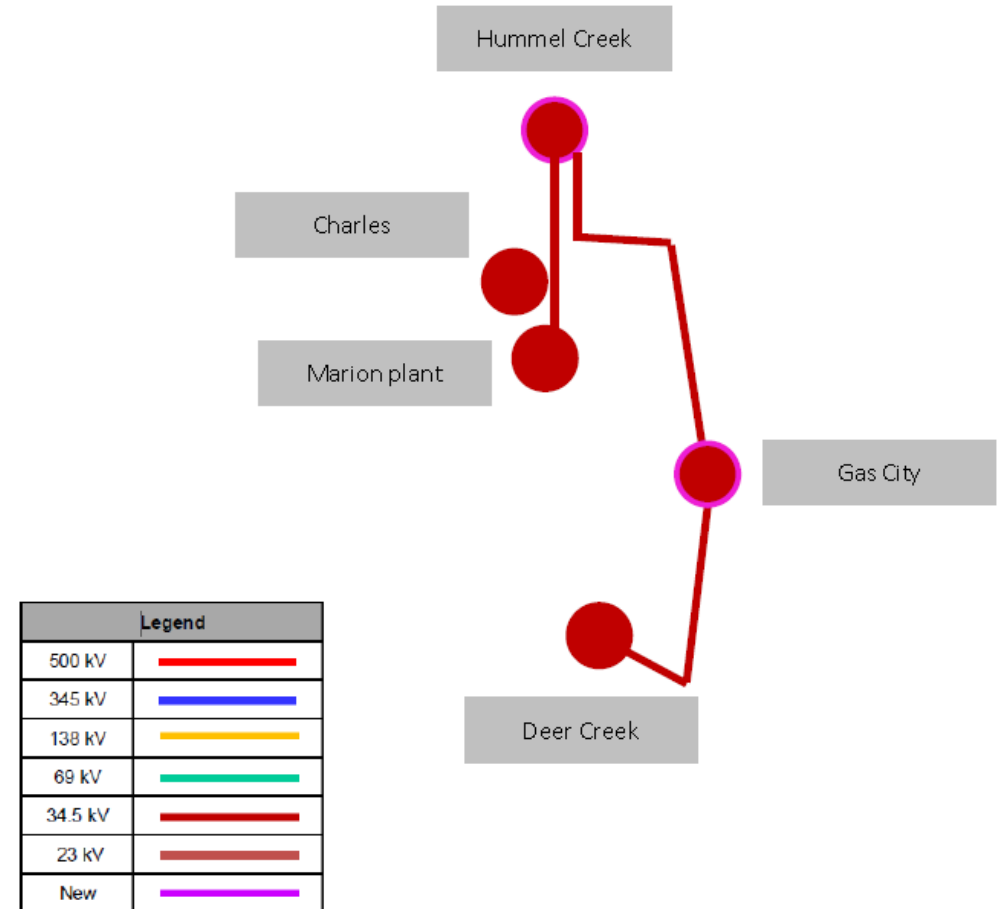

# AEP Transmission Zone M-3 Process Eastern Muncie Indiana

**Need Number:** AEP-2019-IM001

**Process Stage:** Submission of Supplemental Project for inclusion in the Local Plan 10/3/2019

**Previously Presented:**

Needs Meeting 2/20/2019  
Solutions Meeting 6/17/2019

**Project Driver:**

Equipment Condition/Performance/Risk

**Specific Assumption Reference:**

AEP Guidelines for Transmission Owner Identified Needs (AEP Assumptions Slide 8)

**Problem Statement:**

Medford – Blaine Street 34.5 kV (~3.3 Miles)

- 1940's vintage wood crossarm construction with cap and pin insulators
- There are currently 40 open conditions on this line. This trend is expected to increase as the structures and conductor age.

Medford – Haymond 34.5 kV (section in question is Medford – near 21st Street ~3.3 miles)

- 1940's vintage wood crossarm construction with cap and pin insulators
- There are currently 29 open conditions on this segment of the line. This trend is expected to increase as the structures and conductor age.

Haymond – Blaine Street 34.5 kV (~3.7 miles)

- 1950's vintage wood crossarm construction with cap and pin insulators
- There are currently 7 open conditions on this segment of the line. This trend is expected to increase as the structures and conductor age.

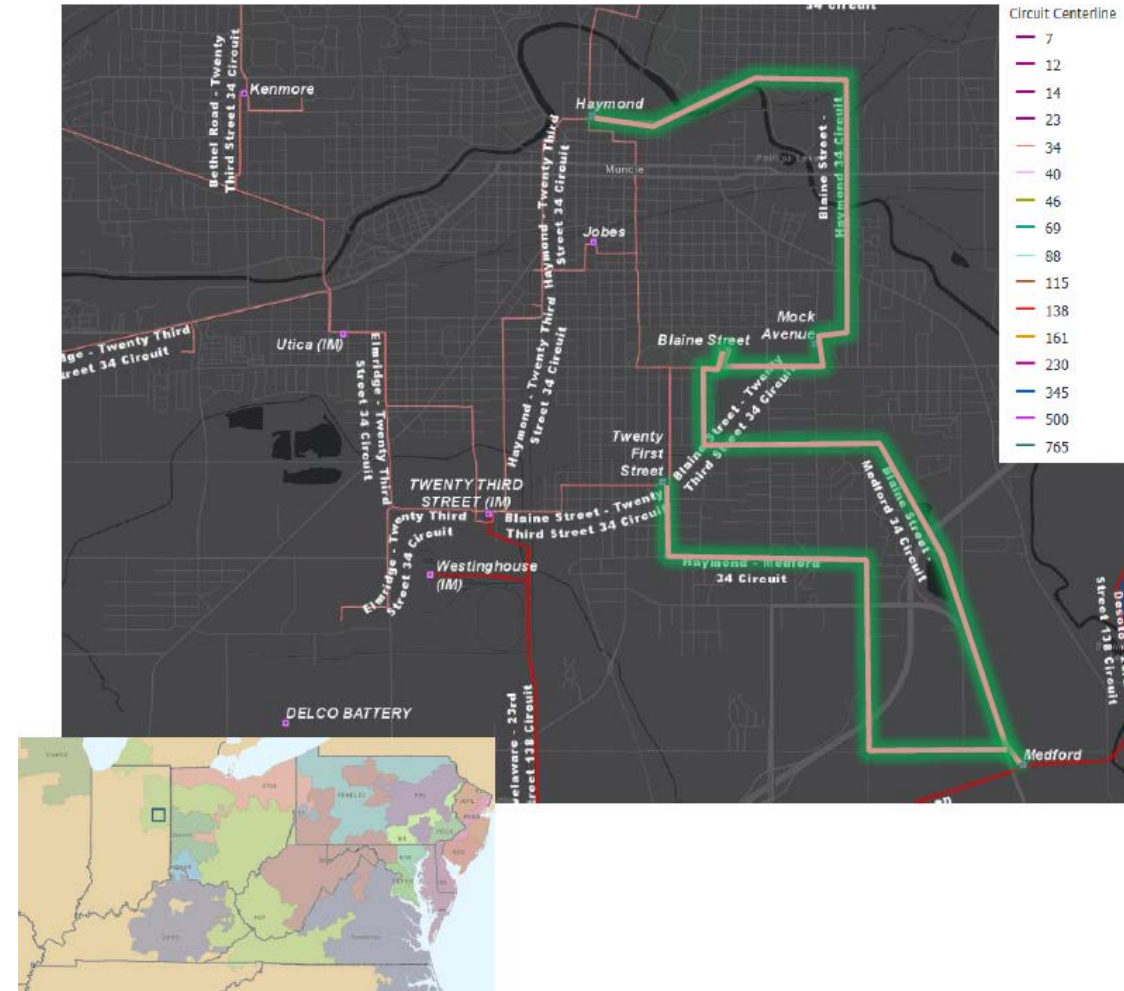



# AEP Transmission Zone M-3 Process Eastern Muncie Indiana

**Need Number:** AEP-2019-IM001

**Process Stage:** Submission of Supplemental Project for inclusion in the Local Plan 10/3/2019

**Selected Solution:**

Rebuild the 3.3 mile Medford – Blaine Street 34.5kV line to 69kV using 795 Drake ACSR. **S2018.1**

**Estimated Cost: \$9.8M**

Retire the 3.7 mile Haymond – Blaine 34.5kV line. **S2018.2**

**Estimated Cost: \$1.2M**

Retire the 3.3 mile Haymond – Medford 34.5kV line portion south of 21st street station. **S2018.3**

**Estimated Cost: \$0.9M**

Build a new Blaine Street double circuit extension to facilitate the retermination of the Haymond and 23rd street lines into Blaine Street. **S2018.4**

**Estimated Cost: \$2.5M**

Retire the unused breaker E at Haymond station. **S2018.5**

**Estimated Cost: \$0M**

**Total Estimated Cost: \$14.4M**

**Projected In-Service: 12/1/2022**

**Supplemental Project ID: S2018.1-.5**

**Project Status: Scoping**

**Model: N/A**

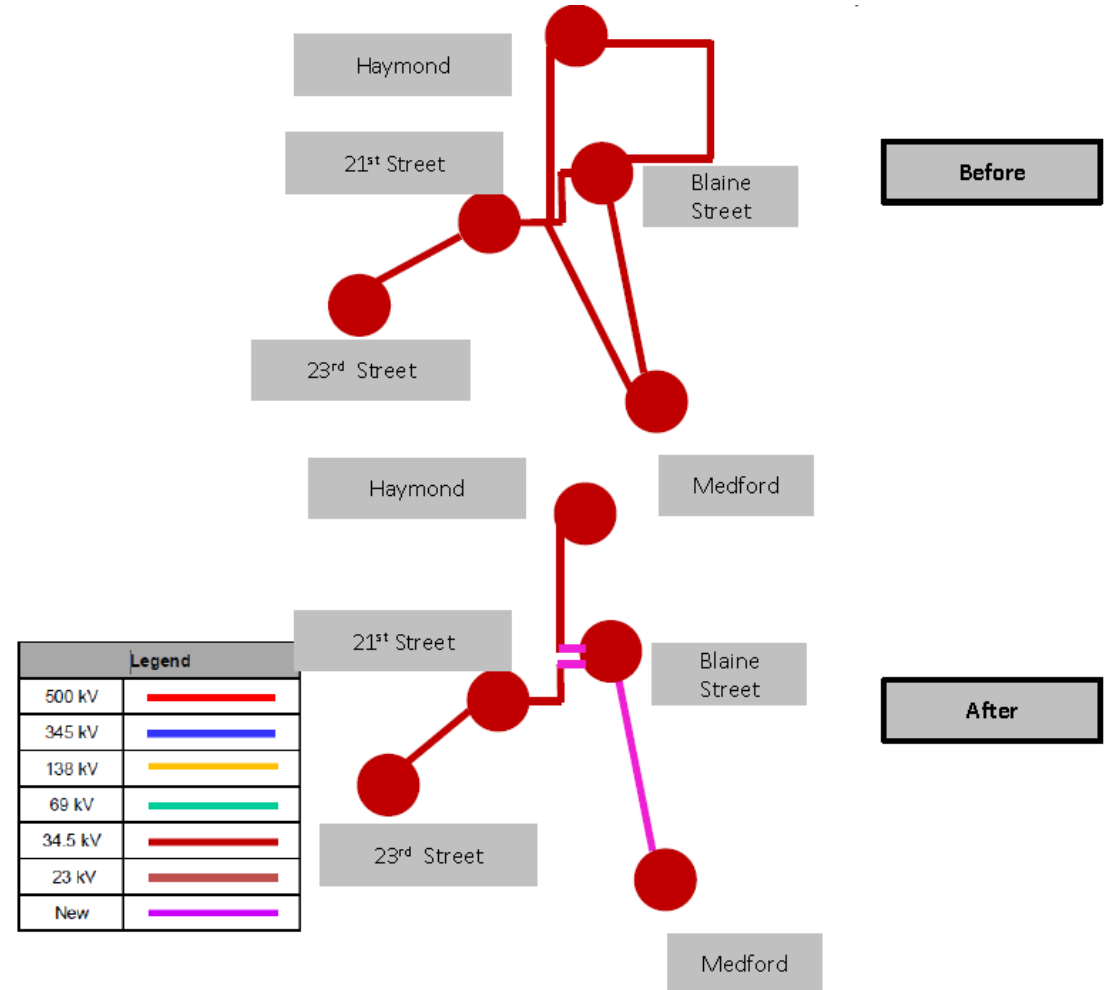

# AEP Transmission Zone M-3 Process Tanners Creek

**Need Number:** AEP-2019-IM003

**Process Stage:** Submission of Supplemental Project for inclusion in the Local Plan 10/3/2019

**Previously Presented:**

Needs Meeting 2/20/2019

Solutions Meeting 4/23/2019

**Project Driver:**

Operational Efficiency & Flexibility

**Specific Assumption Reference:**

AEP Guidelines for Transmission Owner Identified Needs (AEP Assumptions Slide 8)

**Problem Statement:**

Tanners Creek 345 kV

Currently a line fault on the Dearborn circuit causes 5 EHV breakers to open. This is above the AEP max of 4 and must be addressed.

According to the DEDSTFMRS PJM document, 200 kV+ facilities with 7+ elements are required to be in a complete breaker and a half setup at a minimum. This facility has 9 elements and is currently in an incomplete breaker and a half setup.



# AEP Transmission Zone M-3 Process Tanners Creek

**Need Number:** AEP-2019-IM003

**Process Stage:** Submission of Supplemental Project for inclusion in the Local Plan 10/3/2019

**Selected Solution:**

Install 2 new 345 kV breakers and move the existing M2 breaker into the new N string. Terminate the Dearborn line and the transformer into the new N string. Install a new 345 kV breaker "T" to complete the T string.

**Estimated Cost:** \$5.93 M

**Projected In-Service:** 03/07/2021

**Supplemental Project ID:** S2019

**Project Status:** Scoping

**Model:** N/A

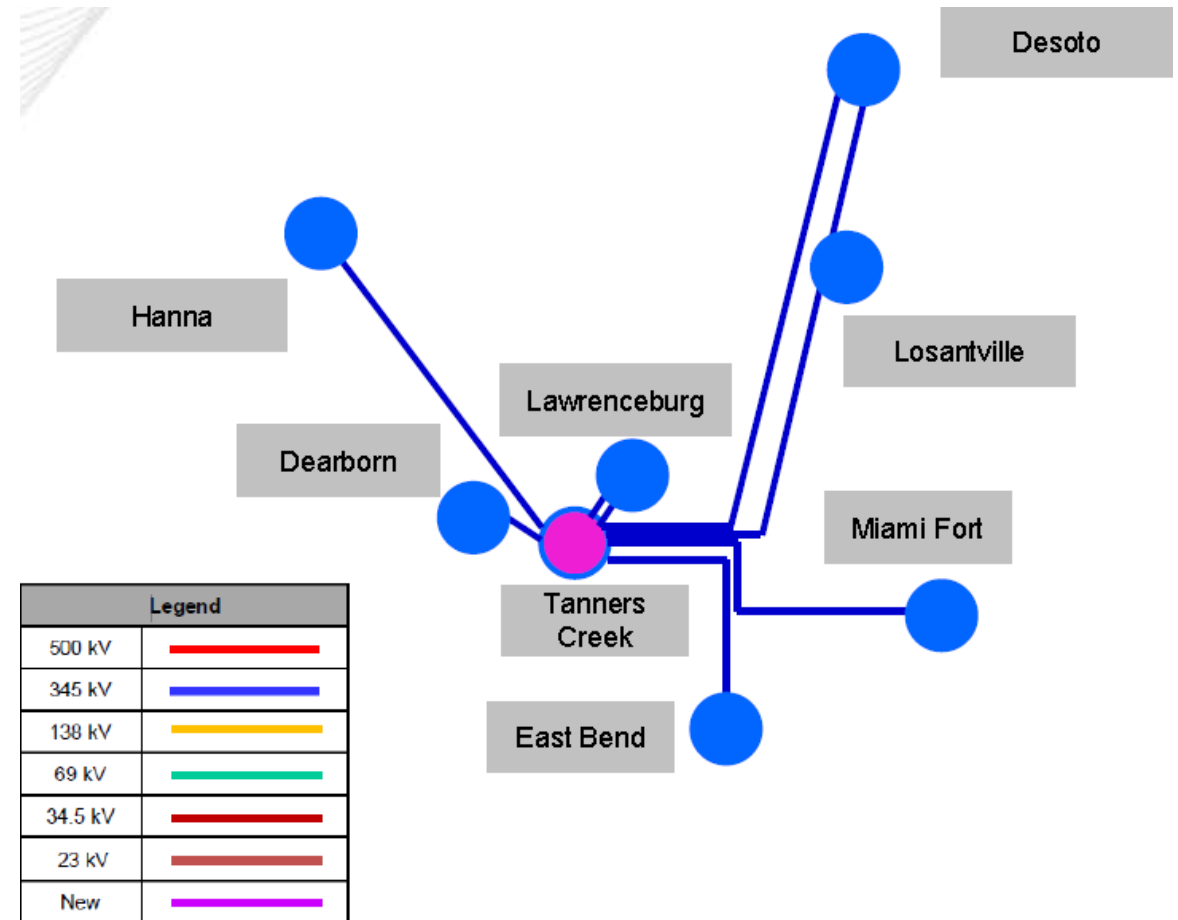



# AEP Transmission Zone M-3 Process Greentown

**Need Number:** AEP-2019-IM004

**Process Stage:** Submission of Supplemental Project for inclusion in the Local Plan 10/3/2019

**Selected Solution:**

Greentown 765/230/138 kV station:

Install two 138 kV breakers to terminate the 765/138 kV Transformer into a breaker and a half string. This work will be done in conjunction with the significant MISO work being planned at this station.

**Estimated Cost:** \$2.7 M

**Projected In-Service:** 2/15/2023

**Supplemental Project ID:** S2020

**Project Status:** Scoping

**Model:** N/A

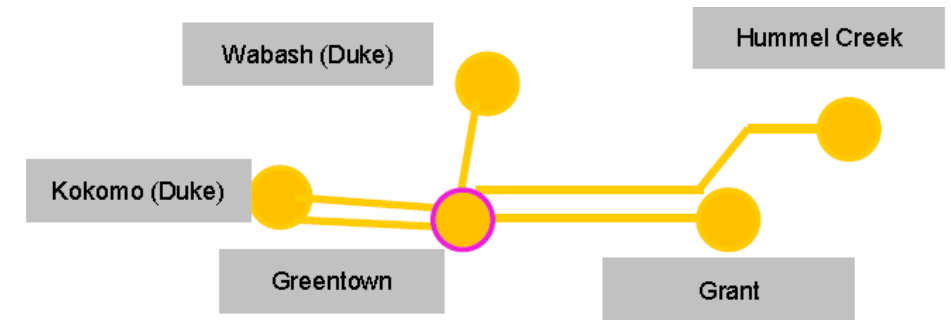

Legend	
500 kV	
345 kV	
138 kV	
69 kV	
34.5 kV	
23 kV	
New	

# AEP Transmission Zone M-3 Process

## Jay - Allen

**Need Number:** AEP-2019-IM008

**Process Stage:** Submission of Supplemental Project for inclusion in the Local Plan 10/3/2019

**Previously Presented:**

Needs Meeting 2/20/2019

Solutions Meeting 5/20/2019

**Project Driver:**

Equipment Condition/Performance/Risk

**Specific Assumption Reference:**

AEP Guidelines for Transmission Owner Identified Needs (AEP Assumptions Slide 8)

**Problem Statement:**

Jay – Lincoln 138 kV line

- The Jay to Lincoln Line is a 1953 wood pole, H-Frame line with 94% of its original structures.
- Currently 95 structures have at least one open condition, which relates to 22% of the structures.
- Out of the 108 open conditions relating to structure, 28 deal with the pole and crossarm specifically.
- Out of the 130 closed conditions related to structure, 85 dealt with the pole or crossarm. Due to the type of construction, we will continue to see pole and crossarm related issues on this line.
- In addition, TFS currently has 13 poles identified for replacement.

Decatur – Berne 69 kV line

- 1966 vintage wood pole line
- This line is currently subject to 95 open conditions with the majority being structural issues. This trend is expected to increase as the structures and conductor age.

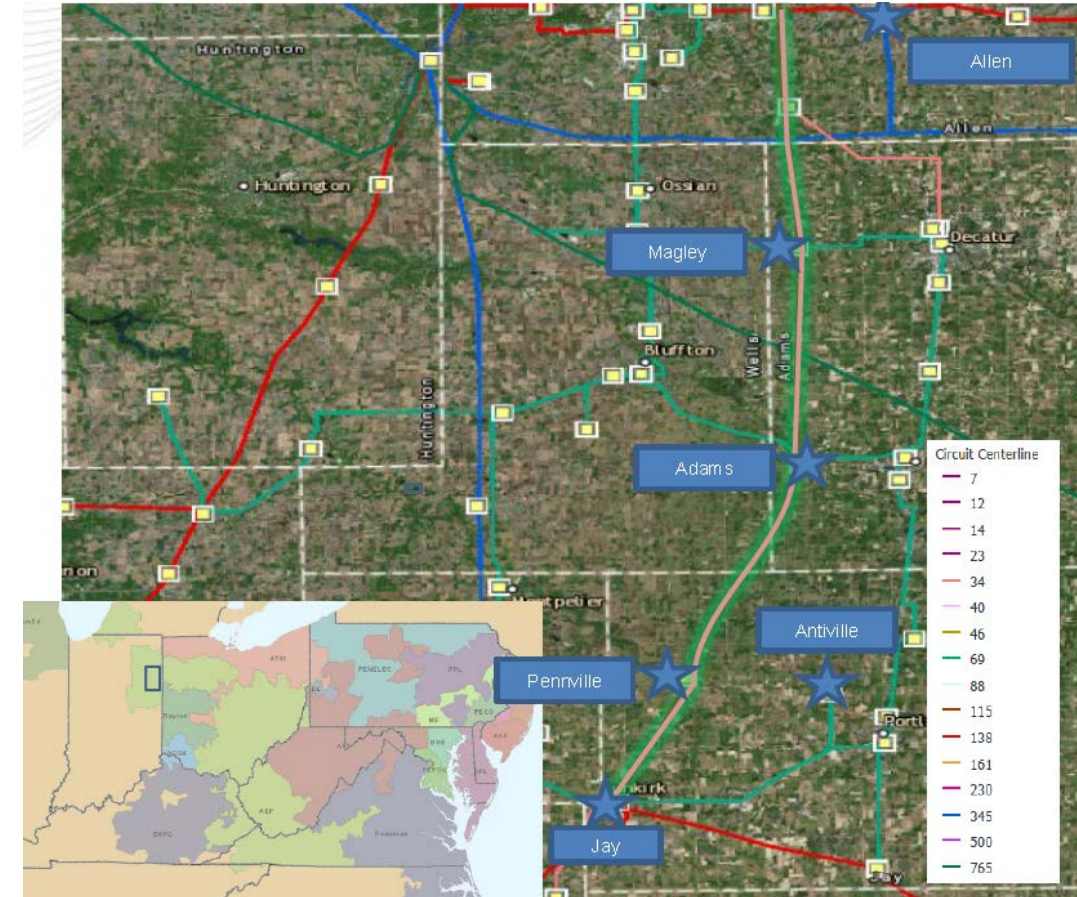

# AEP Transmission Zone M-3 Process

## Jay - Allen

**Need Number:** AEP-2019-IM008

**Process Stage:** Submission of Supplemental Project for inclusion in the Local Plan 10/3/2019

**Previously Presented:**

Needs Meeting 2/20/2019

Solutions Meeting 5/20/2019

**Project Driver:**

Customer Service

**Specific Assumption Reference:**

AEP Guidelines for Transmission Owner Identified Needs (AEP Assumptions Slide 7)

**Problem Statement:**

Antiville

- Potential economic developments have not materialized due to system load and reliability imitations.

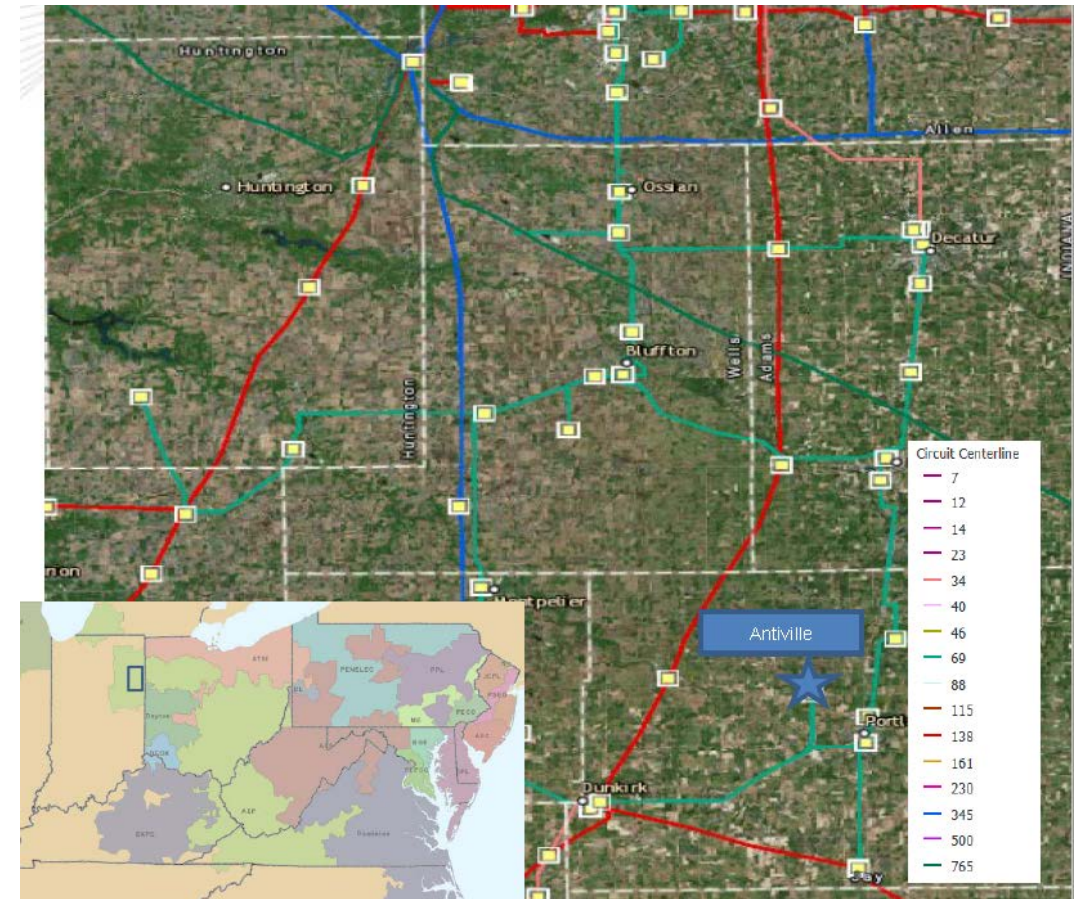

# AEP Transmission Zone M-3 Process Jay - Allen

**Need Number:** AEP-2019-IM008

**Process Stage:** Submission of Supplemental Project for inclusion in the Local Plan 10/3/2019

**Selected Solution:**

Antiville 69k V station

Rebuild the station's throughpath to allow for connection to the new Jay – N. Portland 69kV line. **S2021.1 Cost: \$0.4M**

Antiville 69 kV Tap

Retire the 69kV Antiville radial tap line. **S2021.2 Cost: \$0.3M**

Pennville – Allen 138 kV line:

Rebuild the ~38.5 mile Jay – Allen 138kV line from Pennville to the juncture west of Allen station. This line is a single circuit 138kV line using 795 ACSR **S2021.3 Cost: \$70.3M**

**Total Estimated Cost:** \$71.0M

**Projected In-Service:** 6/1/2022

**Supplemental Project ID:** S2021.1-.3

**Project Status:** Scoping

**Model:** 2024 RTEP

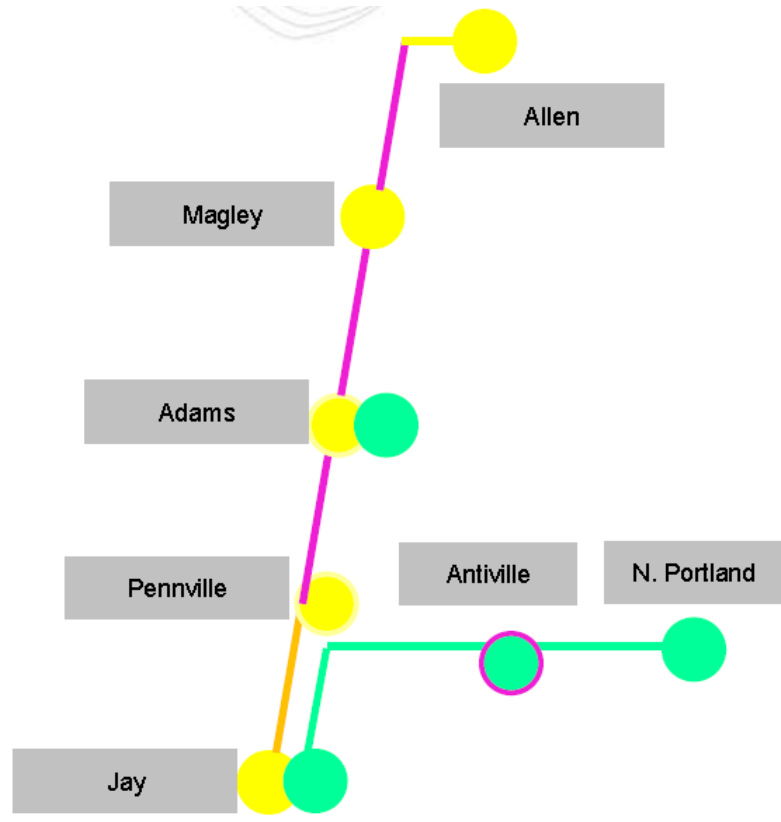

Legend	
500 kV	
345 kV	
138 kV	
69 kV	
34.5 kV	
23 kV	
New	



# AEP Transmission Zone M-3 Process New Buffalo Area Improvements

**Need Number:** AEP-2019-IM009

**Process Stage:** Submission of Supplemental Project for inclusion in the Local Plan 10/3/2019

**Previously Presented:**

Needs Meeting 4/23/2019

Solutions Meeting 6/17/2019

**Project Driver:**

Equipment Condition/Performance/Risk

**Specific Assumption Reference:**

AEP Guidelines for Transmission Owner Identified Needs (AEP Assumptions Slide 8)

**Problem Statement:**

Bridgman 69 kV Station

Breakers C, A, & B 69 kV

- 1968 vintage FK Oil breakers
- Fault Operations: C(204), A(48) & B(58) – Recommended(10)
- Oil filled breakers have much more maintenance required due to oil handling that their modern, vacuum counterparts do not require. Finding spare parts for these units is difficult or impossible, and these models are no longer vendor supported

Three Oaks 69kV Station

Breakers C & B 69 kV

- 1968 vintage FK Oil breakers
- Fault Operations: C(73) & B(63) – Recommended(10)
- Oil filled breakers have much more maintenance required due to oil handling that their modern, vacuum counterparts do not require. Finding spare parts for these units is difficult or impossible, and these models are no longer vendor supported

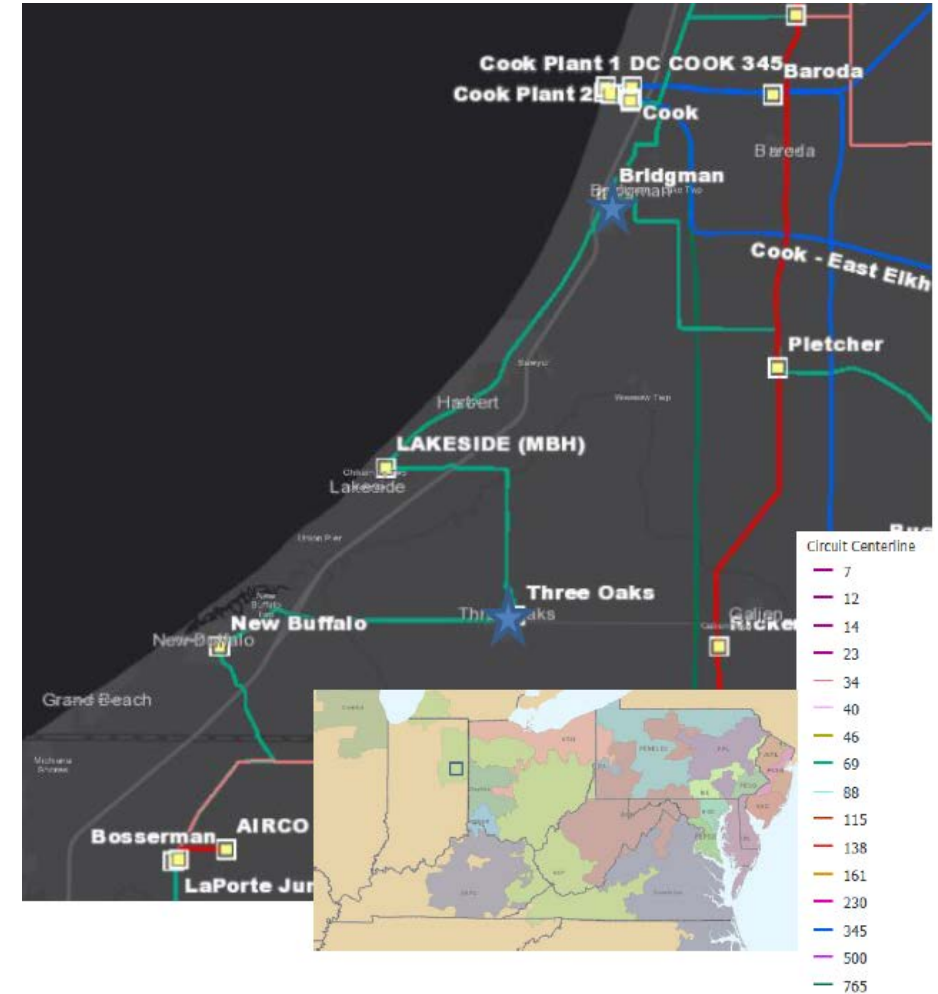

# AEP Transmission Zone M-3 Process New Buffalo Area Improvements

**Need Number:** AEP-2019-IM009

**Process Stage:** Submission of Supplemental Project for inclusion in the Local Plan 10/3/2019

**Previously Presented:**

Needs Meeting 4/23/2019

Solutions Meeting 6/17/2019

**Project Driver:**

Equipment Condition/Performance/Risk

**Specific Assumption Reference:**

AEP Guidelines for Transmission Owner Identified Needs (AEP Assumptions Slide 8)

**Problem Statement:**

LaPorte 69 kV Station

- Breaker B 69 kV
  - 1968 vintage FK Oil breakers
  - Fault Operations: B(62) – Recommended(10)
  - Oil filled breakers have much more maintenance required due to oil handling that their modern, vacuum counterparts do not require. Finding spare parts for these units is difficult or impossible, and these models are no longer vendor supported
- Transformer #1 138/69/3 4kV
  - 1967 vintage
  - Its showing significant signs of deterioration and has high levels of Carbon Dioxide dissolved in the oil.
  - Equipment condition concerns include dielectric strength breakdown (winding insulation), short circuit strength breakdown (due to the amount of through fault events), and accessory damage (bushings).

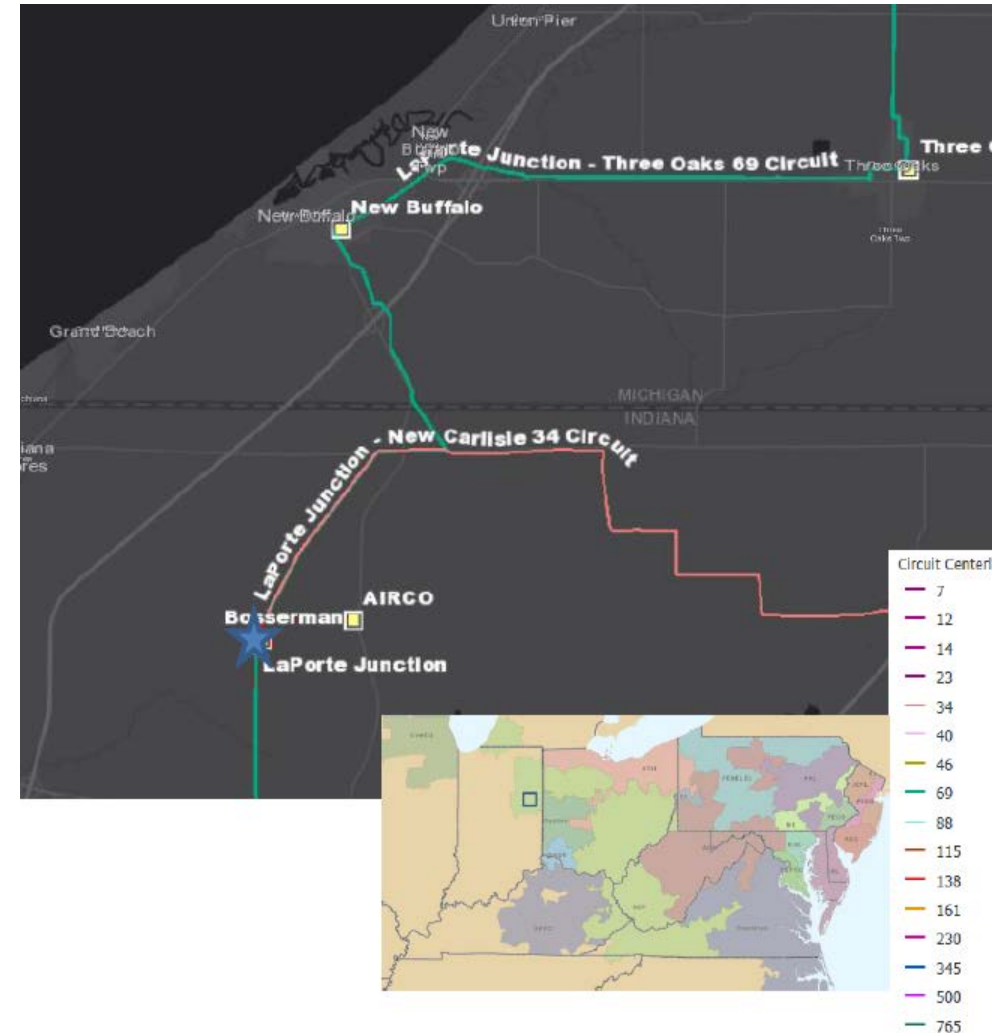

# AEP Transmission Zone M-3 Process New Buffalo Area Improvements

**Need Number:** AEP-2019-IM009

**Process Stage:** Submission of Supplemental Project for inclusion in the Local Plan 10/3/2019

**Previously Presented:**

Needs Meeting 4/23/2019

Solutions Meeting 6/17/2019

**Project Driver:**

Equipment Condition/Performance/Risk

**Specific Assumption Reference:**

AEP Guidelines for Transmission Owner Identified Needs (AEP Assumptions Slide 8)

**Problem Statement:**

Laporte Junction – New Buffalo (IN) 69 kV Line (~4 Miles)

- 1960's vintage wood crossarm construction
- Approximately 67% of the structures have Insect Damage
- There are currently 132 open conditions on this line with majority being structure issues. The O&M cost of the line is expected to increase as the age of the line increases.

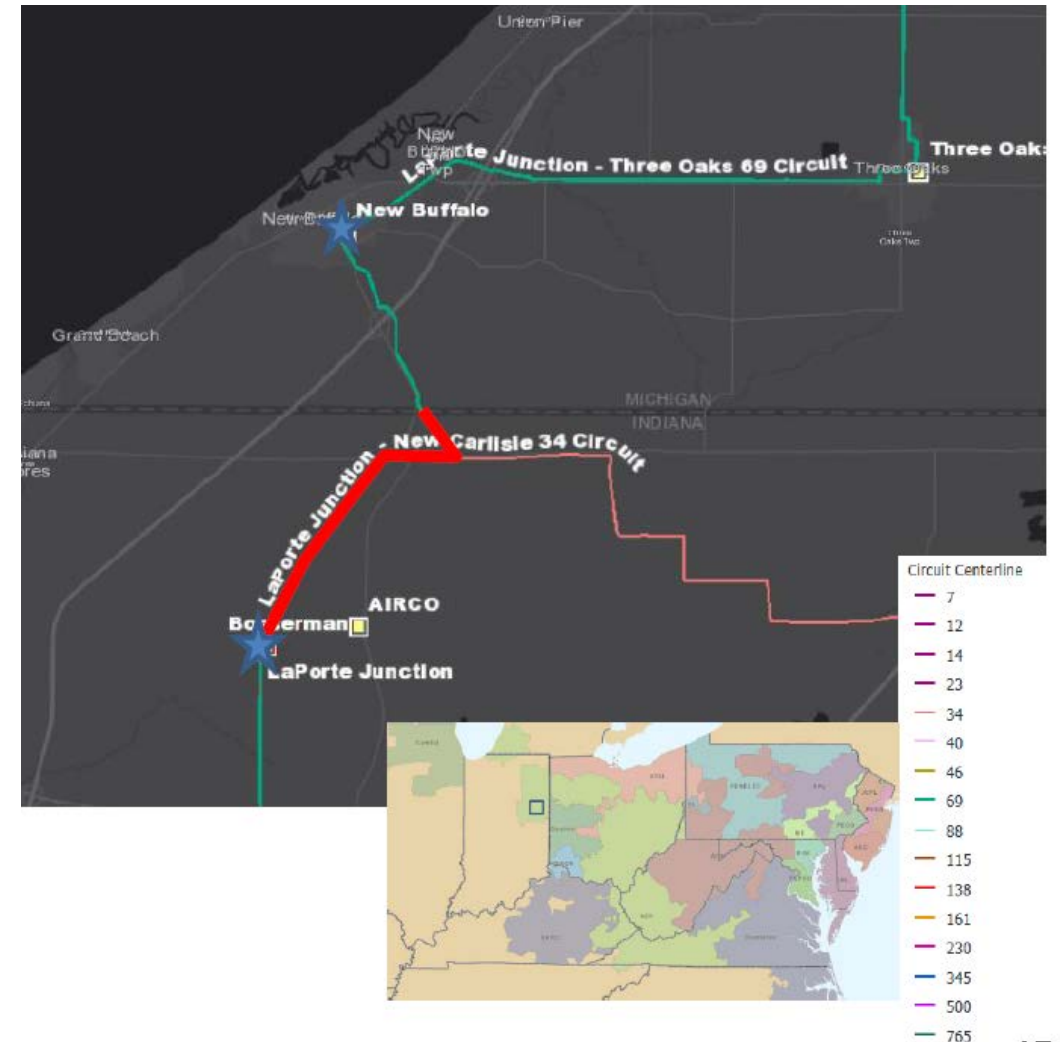

# AEP Transmission Zone M-3 Process New Buffalo Area Improvements

**Need Number:** AEP-2019-IM009

**Process Stage:** Submission of Supplemental Project for inclusion in the Local Plan 10/3/2019

**Selected Solution:**

Rebuild 3.52 miles of the LaPorte-New Buffalo 69 kV line and reterminate into Bosserman station. **S2022.1**

**Estimated Cost:** \$7.7M

At Bosserman station, install new 138/69kV transformer, install 69kV low side breaker on TR#1, and 69kV line breaker B towards Three Oaks Station **S2022.2**

**Estimated Cost:** \$3.6M

At Three Oaks station, replace 69kV line breakers C and B **S2022.3**

**Estimated Cost:** \$2.7M

At Bridgman station, replace 69kV line breakers B, A and C. **S2022.4**

**Estimated Cost:** \$1.2M

Retire Laporte Junction Station **S2022.5**

**Estimated Cost:** \$0.5M

**Total Estimated Cost:** \$15.7M

**Projected In-Service:** 12/15/2020

**Supplemental Project ID:** S2022.1 - .5

**Project Status:** Engineering

**Model:** N/A

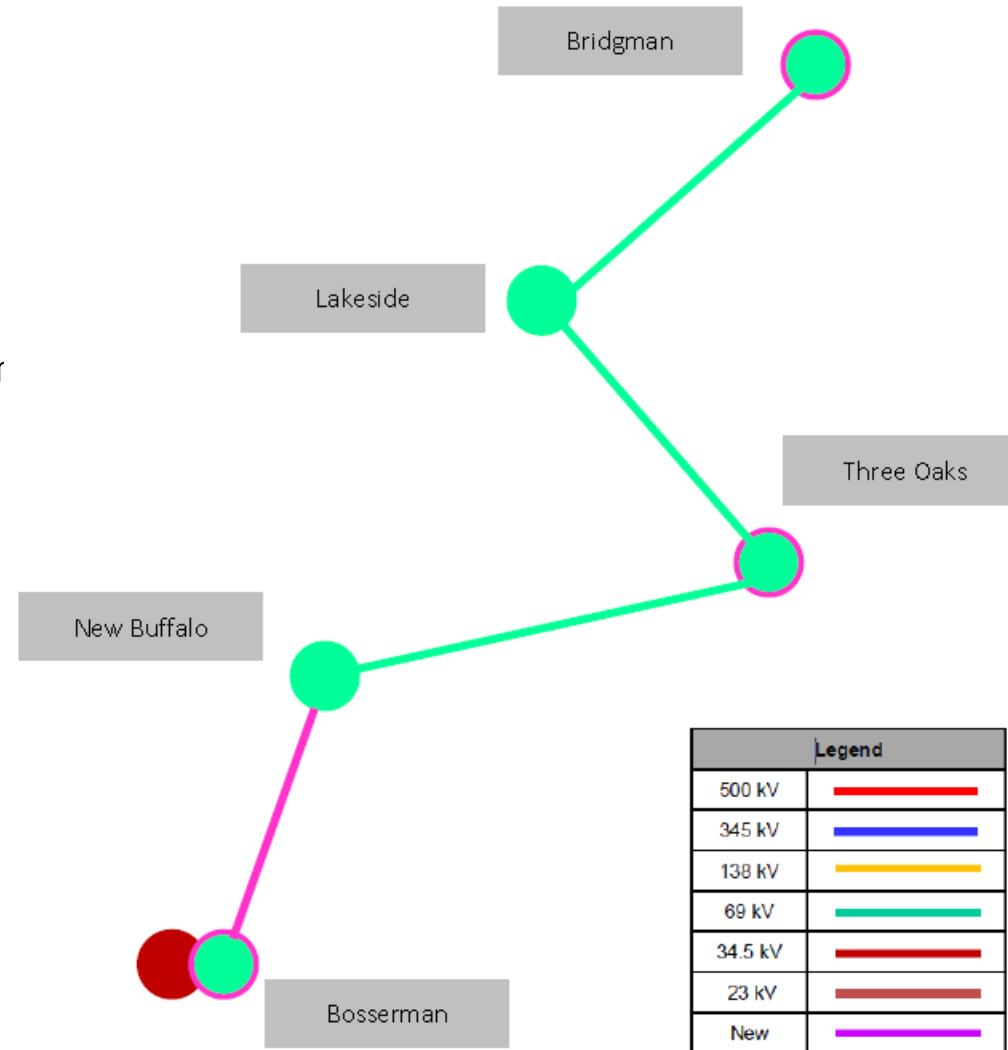

# AEP Transmission Zone M-3 Process West End Rebuild

**Need Number:** AEP-2019-IM011

**Process Stage:** Submission of Supplemental Project for inclusion in the Local Plan 10/3/2019

**Previously Presented:**

Needs Meeting 4/23/2019

Solutions Meeting 5/20/2019

**Project Driver:**

Customer Request

**Specific Assumption Reference:**

AEP Guidelines for Transmission Owner Identified Needs (AEP Assumptions Slide 7)

**Problem Statement:**

West End 34.5 kV station

- AEP I&M Distribution is rebuilding and reconfiguring their West End Station to address aging equipment and capacity concerns.

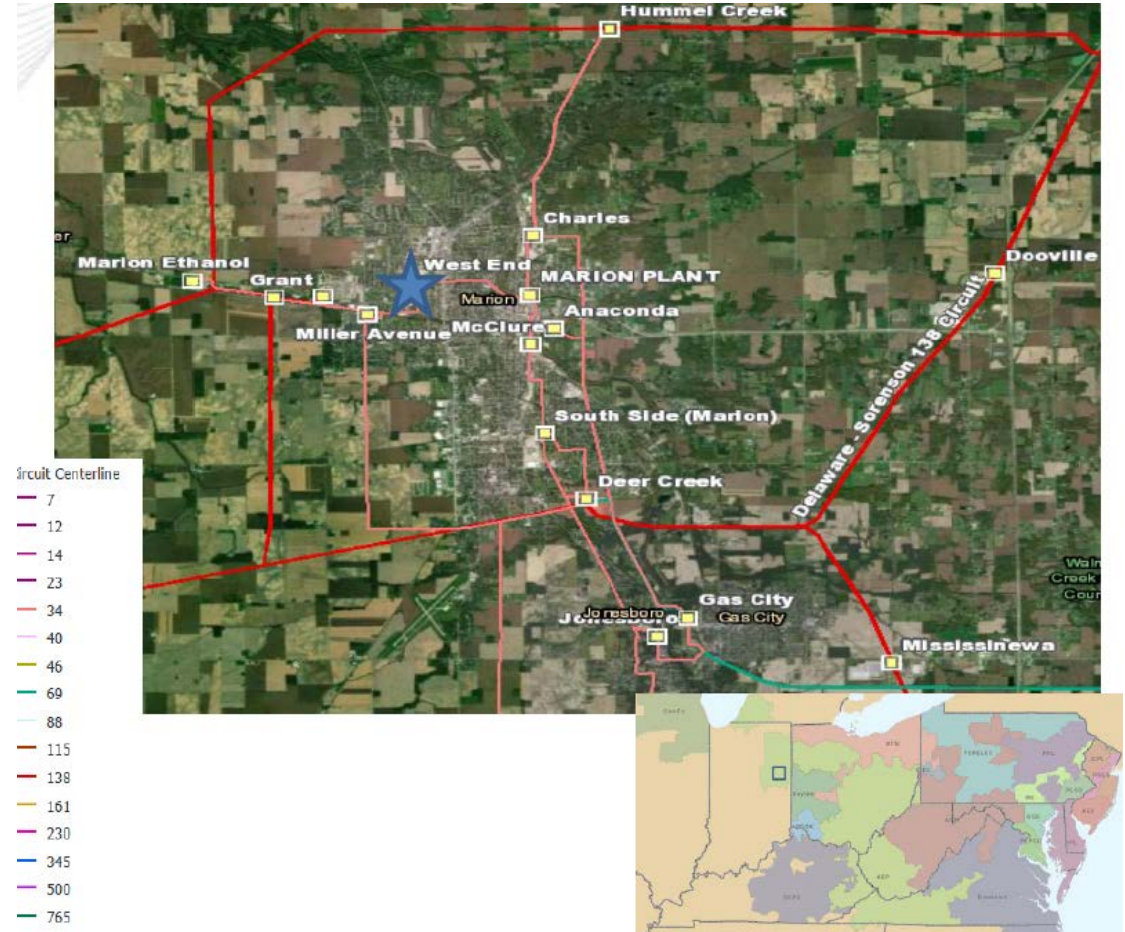

# AEP Transmission Zone M-3 Process West End Rebuild

**Need Number:** AEP-2019-IM011

**Process Stage:** Submission of Supplemental Project for inclusion in the Local Plan 10/3/2019

**Selected Solution:**

West End 34.5 kV station:

Rebuild the through-path of this station to accommodate the distribution work required.

**Estimated Cost:** \$1.2M

**Projected In-Service:** 11/03/2020

**Supplemental Project ID:** S2023

**Project Status:** Scoping

**Model:** 2024 RTEP

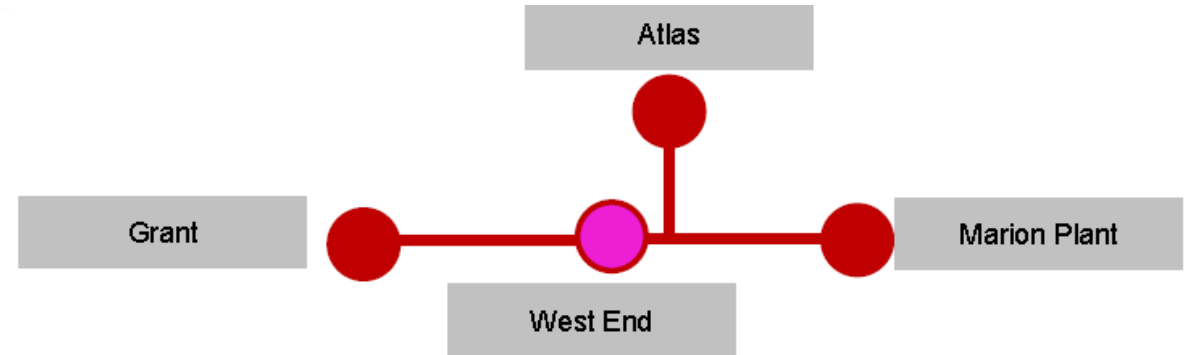

Legend	
500 kV	
345 kV	
138 kV	
69 kV	
34.5 kV	
23 kV	
New	

## Revision History:

4/12/2019 – V1 – Local Plan posted to pjm.com for S1791 – S1792

8/29/2019 – V2 – Local Plan posted to pjm.com for S1851 – S1867

10/3/2019 – V3 – Slide #4, Remove "Customer Service #2: Roseville is still being evaluated."

– Local Plan posted to pjm.com for S1994 – S2023

10/7/2019 – V4 – Remove slides #24 and #25, S1857.1-.4